

■電気的特性

ELECTRICAL CHARACTERISTICS

全抵抗値範囲 Total resistance range	10Ω～1MΩ
全抵抗値許容差 Total resistance tolerance	±20%(±10%)
残留抵抗値 End resistance	1%又は3Ωの大なる方以下 1% or 3Ω, whichever is greater
抵抗変化特性 Resistance taper	B(直線型) (Linear)
接触抵抗変化 Contact resistance variation	1%又は1Ωの大なる方以下 1% or 1Ω, whichever is greater
定格電力 Power rating	0.5W/70℃ 0W/125℃
最高使用電圧 Max. input voltage	250V DC又は定格電力のいずれか小さい方 250V DC or power rating, whichever is smaller
抵抗温度係数 Temp. coefficient	±100ppm/℃ 200Ω～1MΩ ±250ppm/℃ 上記以外の抵抗値 Other value
絶縁抵抗 Insulation resistance	100MΩ以上 (500V DC) 100MΩ Min. (500V DC)
耐電圧 Dielectric strength	500V AC 1分間 500V AC 1 minute
電気的回転角度 Electrical angle	240°±10°

■機械的特性

MECHANICAL CHARACTERISTICS

機械的回転角度 Mechanical angle	250°±10°
回転トルク Shaft torque	19.6mN・m max. (200gf・cm max.)
ストップ強度 Stop strength	49mN・m min. (500gf・cm min.)
使用温度範囲 Operating temp. range	-55℃～+125℃
重量 Weight	0.5g max.: P, W 0.6g max.: X, S

■環境特性

ENVIRONMENTAL CHARACTERISTICS

試験項目 Test item	試験条件 Test condition	規格 Standard
はんだ耐熱性 Soldering heat	350℃ 3 sec	△R/R≤±1%
回転寿命 Rotation life	200サイクル (200 cycles)	△R/R≤±10%
負荷寿命 Load life	70℃ 0.5W 1000 hours	△R/R≤±3%
熱衝撃 Thermal shock	-55℃, +125℃ (30minutes) 5 cycles	△R/R≤±2%
高周波振動 Vibration	10～2kHz 振幅(amplitude) 1.5mm(20G) 12 hours	△R/R≤±1%
衝撃 Shock	50G 6 msec. 6 directions for 3 times each	△R/R≤±2%
高温露出 High temperature exposure	+125℃, 250 hours	△R/R≤±3%
耐湿負荷寿命 Moisture and load life	+40℃, 90～95%RH 0.5W 500 hours	△R/R≤±5%
耐湿性 Moisture resistance	-10℃～+65℃ (90～95%RH) 0.5W 240 hours	△R/R≤±3%
温水浸漬 Seal test	+85℃ hot water 1 minute	3 bubbles max.
耐溶剤性 Solvent	アルコール等 Alcohol etc.	洗浄可能 Possible for washing

△R/R: 全抵抗値変化 Change in total resistance

外形寸法図

(Unit : mm)

OUTLINE DIMENSIONS

● RJC06P

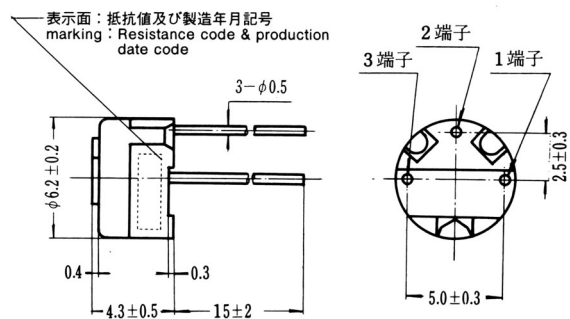

● RJC06W

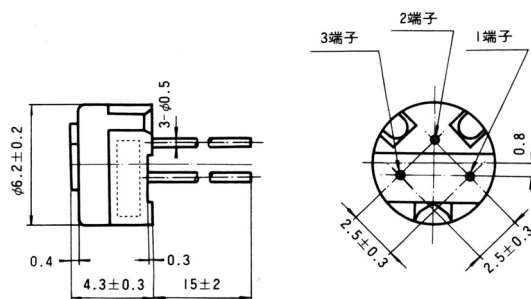

● RJC06X

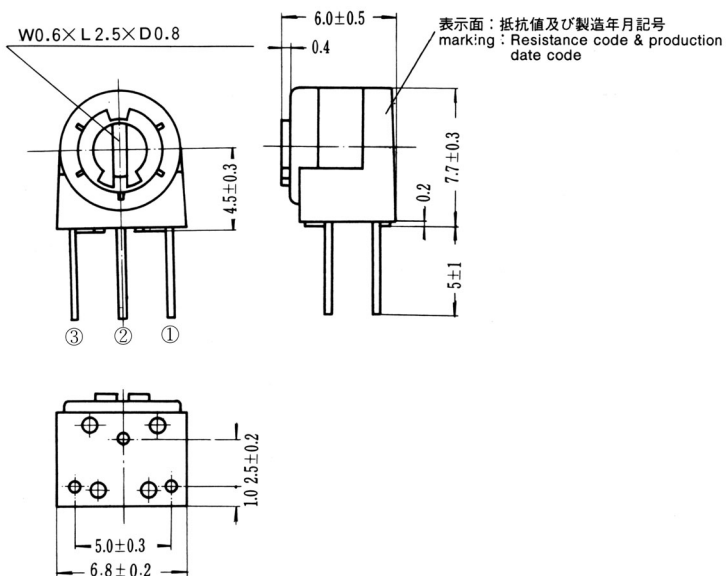

● RJC06S

