

# Plastic Push-Pull Lock Connectors

## RP13 Series

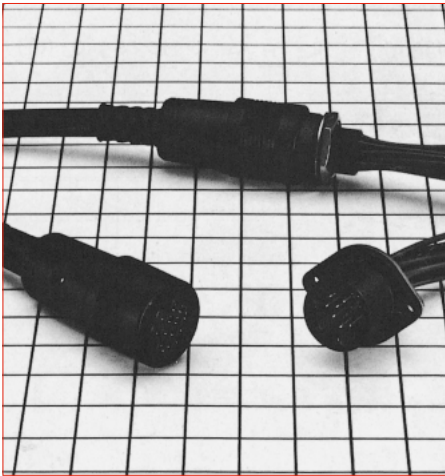

### ■ Features

#### 1. Superior mating operability

- A secure mating condition is achieved by simply pushing the plug on to the receptacle; Pull back on the locking sleeve to easily un-mate the connector.
- Index marks are provided on the plug for easy mating alignment.
- Our proprietary guide keys aid with making a correct mating orientation in blind or low light conditions.

#### 2. Light weight and robust design

The strong outer shell is made of glass-reinforced polycarbonate resin, producing light but durable connectors.

#### 3. Available in an anti-static version

The anti-static version connects the plug and receptacle housing together in such a way that the surrounding shield guards against the effects of static electricity.

#### 4. Variation

Items	
Number of contacts	13, 15, 20
Connector type	Plug and jack: Straight, Receptacle: Straight, right angle
Plug termination type	Crimp
Receptacle termination type	Crimp, PCB dip
Receptacle mounting style	Flange, jam nut

### ■ Product Specifications

Ratings	Rated current	Standard type : 2A (when using a wire of at least 24 AWG) Anti-static type : 2A (when using a wire of at least 22 AWG)	Operating temperature range	-10 to +60°C
	Rated voltage	For 13 and 15 contact positions : AC 30V, DC 42V 20 contacts : AC 100V, DC 140V	Storage temperature range	-10 to +60°C

Items	Specifications	Conditions
1. Contact resistance	For 13 and 15 contact positions : 15mΩ max. 20 contacts : 30mΩ max.	Measured at DC 1A
2. Insulation resistance	1,000MΩ min.	Measured at DC 250V
3. Withstanding voltage	No flashover or dielectric breakdown.	AC 300V for 1 minute
4. Vibration resistance	No electrical discontinuity for 10μs or greater.	10 to 55Hz/cycle, amplitude : 0.75mm, 3 axis directions, 2 hours each
5. Shock resistance	No electrical discontinuity for 10μs or greater.	Acceleration : 490m/s <sup>2</sup> , duration : 11ms, 3 axis directions, 3 cycles each
6. Mating cycles	Contact resistance : For 13 and 15 contact positions : 20mΩ max. For 20 contact positions : 45mΩ max.	1,000 times
7. Temperature cycle	Insulation resistance : 100MΩ min.	-55°C : 30 minutes → Normal temperature : 10 to 15 minutes → 85°C : 30 minutes → Normal temperature : 10 to 15 minutes, leave total 5 cycles
8. Moisture resistance	Insulation resistance : 10MΩ min. (at high humidity) 100MΩ min. (when dry)	Temperature : 40°C, relative humidity : 90 to 95%, leave 96 hours

### ■ Materials / Finish

Items	Material	Finish	Remarks
Plug	Exterior, insulator	Polycarbonate resin	UL94V-0
	Clamp	Brass	—
	Bushing	Vinyl chloride resin	—
Receptacle	Exterior, insulator	Polycarbonate resin	UL94V-0
	Female contact	Steel	Nickel plating
	Male contact	Phosphor bronze	Silver plating
Crimp contact	Female contact	Phosphor bronze	Silver plating, gold plating
Crimp contact	Male contact		

## ■ Product Number Structure

Refer to the chart below when determining the product specifications from the product number.  
Please select from the product numbers listed in this catalog when placing orders.

### ● Plug

**RP13A - 12 P A - 13 S C (01)**

①
②
③
④
⑤
⑥
⑦
⑧

<p>① Model name : RP13A Series</p>	<p>⑥ Contact form S : Female contact P : Male contact</p>
<p>② Shell size : The shell size is the outer diameter of the mating end of the plug.</p>	<p>⑦ Contact termination type: A : Straight, PCB dip B : Right-angle, PCB dip C : Contact termination by crimping</p>
<p>③ Shell type P : Straight plug R : Receptacle J : Jack</p>	<p>⑧ Other specifications : A two-digit character is added to indicate other specifications as needed.</p>
<p>④ Shell variation : Connectors are distinguished by A, B, or C if a variation is made within the series.</p>	
<p>⑤ Number of contacts</p>	

### ● Crimp contact

**RP13A - SC - 2 1 1**

①
⑨
⑩
⑪
⑫

<p>① Model name : Indicates the series name. RP13, RP13A, RP19</p>	<p>⑪ Barrel form : RP13, RP13A 1 : For 18 to 22 AWG 2 : For 24 to 28 AWG RP19 1 : For 18 to 22 AWG 2 : For 24 to 30 AWG</p>
<p>⑨ Contact type : SC : Socket type crimp contact (female) PC : Pin type crimp contact (male)</p>	<p>⑫ Identification of plating : 1 : Gold plating 2 : Silver plating</p>
<p>⑩ Contact form : 1 : Loose piece contacts 2 : Reel contacts</p>	

## ■ Standard type

### ● Standard plug

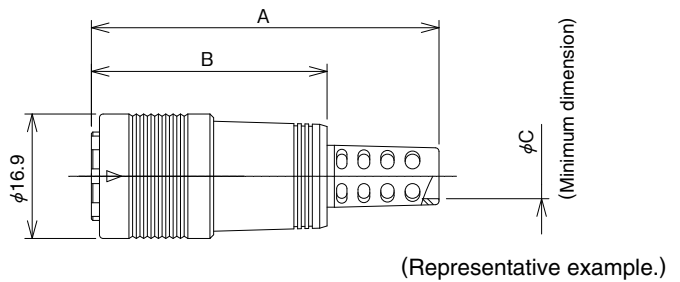

Part No.	HRS No.	No. of contacts	A	B	ϕC	Weight	Part No.	HRS No.	No. of contacts	A	B	ϕC	Weight
RP13A-12PA-13SC(71)	113-0182-4 71	13	47.2	32	6.1	6.0g	RP13A-12PD-20SC(71)	113-0214-9 71	20	52.2	37	6.1	
RP13A-12PB-13SC(31)	113-0184-0 31						5.7						
RP13A-12PD-13SC(71)	113-0186-5 71		52.2	37	6.1		RP13A-12PG-20SC(71)	113-0210-8 71		7.5			
RP13A-12PE-13SC(71)	113-0201-7 71		47.2	32	6.4		RP13A-12PH-20SC(71)	113-0217-7 71		6.4			
RP13A-12PK-13SC(71)	113-1006-7 71		7.1	RP13A-12PK-20SC(71)	113-1012-0 71		7.1						
RP13A-12PS-13SC(71)	113-1026-4 71	15	52.2	37	6.1	RP13A-12PS-20SC(71)	113-1022-3 71	8.1					
RP13A-12PD-15SC(71)	113-0206-0 71					7.1							
RP13A-12PK-15SC(71)	113-0219-2 71					7.5							

(Note) Cable clamping, cable rotation, and other forces may vary with the cable construction. Please make sure that your cable is suitable for use with these connectors before usage and production.

### ● Receptacle (Flange type)

#### (Crimp type)

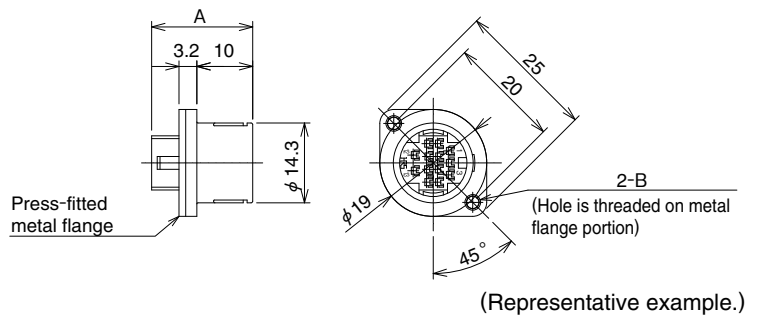

Part No.	HRS No.	No. of contacts	A	B	Weight
RP13A-12RA-13PC(71)	113-0183-7 71	13	18.1	M2.6×0.45	4.0g
RP13A-12RA-15PC(71)	113-0207-3 71	15			
RP13A-12RA-20PC(71)	113-0215-1 71	20	16		

(Remarks) See page 5 for details on mounting hole dimensions.

#### (Dip type)

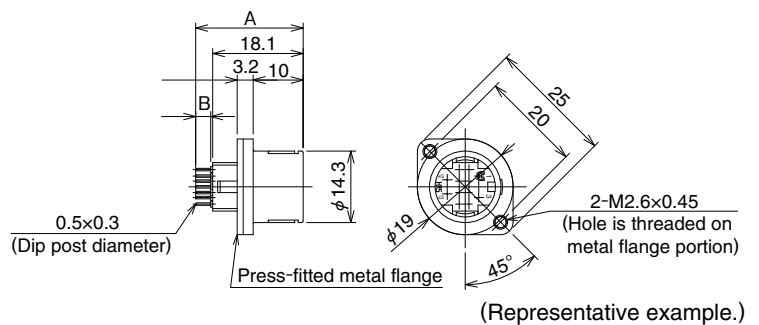

Part No.	HRS No.	No. of contacts	A	B	Weight
RP13A-12RA-13PA(71)	113-0202-0 71	13	21.5	3	5.0g
RP13A-12RA-15PA(71)	113-1002-6 71	15			

(Remarks) See page 5 for details on mounting dimensions and page 7 for details on dip post arrangement sizes.

● Receptacle (Jam nut to be fastened)

(Dip type)

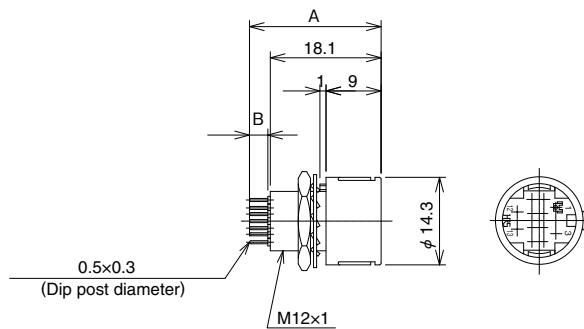

Part No.	HRS No.	A	B	No. of contacts	Weight
RP13A-12RB-13PA(71)	113-0203-2 71	21.5	3	13	3.5g

(Remarks) See page 5 for details on mounting hole dimensions and page 7 for details on dip post arrangement sizes.

● Right-angle, dip type

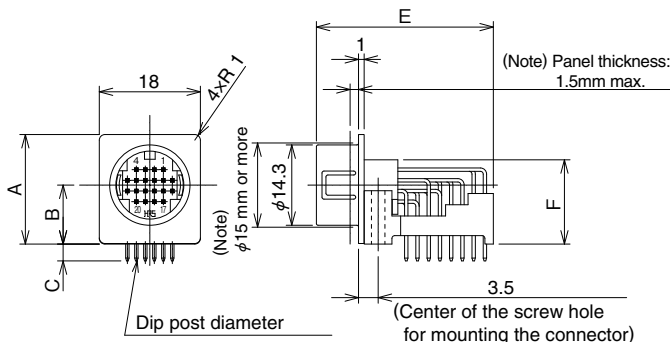

(Note) The mounting panel thickness should be 1.5mm or less. Mounting hole should be φ15 mm or more.

Part No.	HRS No.	No. of contacts	A	B	C	φD	E	F	Weight
RP13A-12RC-13PB	113-1020-8	13	17.5	8.5	3.5	0.64	23.5	13	4.0g
RP13A-12RC-20PB	113-0211-0	20	19.5	10.5	3	0.6	31.5	15	5.0g

(Remarks) See page 7 for details on dip post arrangement sizes.

● Jack

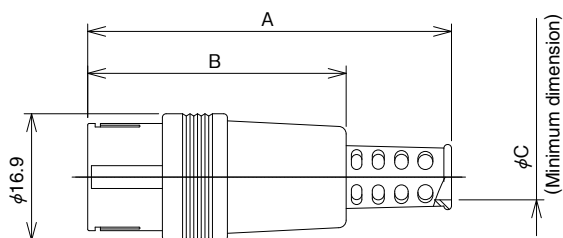

(Representative example.)

Part No.	HRS No.	No. of contacts	A	B	φC	Weight
RP13A-12J-13PC(71)	113-0166-8 71	13	49.1	34.6	6.1	4.5g
RP13A-12JD-15PC(71)	113-1005-4 71	15	54.1	39.6	7.1	
RP13A-12JK-15PC(71)	113-0218-0 71				7.4	
RP13A-12JG-20PC(71)	113-1004-1 71	20	52.6	37.4	7.4	

(Note) Cable clamping, cable rotation, and other forces may vary with the cable construction. Please make sure that your cable is suitable for use with these connectors before usage and production.

◆ Contact

(Male contact)

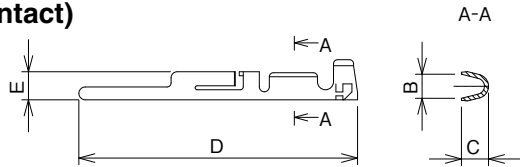

(Representative example.)

For 13 and 15 contact positions

Type	Part No.	HRS No.	Plating	B	C	D	E	Applicable wire size
Loose piece contacts	RP13-PC-122	113-0179-0	Silver plating	1.2	1.35	13.9	1.4	24 to 28 AWG
Reel contacts	RP13-PC-221	113-0360-0	Partial gold plating					
	RP13-PC-222	113-0141-7	Silver plating					

13 contact position for super-thick wires (available for contact position numbers 12 and 13 only)

Type	Part No.	HRS No.	Plating	B	C	D	E	Applicable wire size
Loose piece contacts	RP13-PC-112	113-0178-7	Silver plating	1.6	2.1	13.9	1.4	18 to 22 AWG
Reel contacts	RP13-PC-212	113-0140-4						

For 20 contact positions

Type	Part No.	HRS No.	Plating	B	C	D	E	Applicable wire size
Loose piece contacts	RP19-PC-122	113-0268-8	Silver plating	1.2	1.35	12	1.18	24 to 30 AWG
Reel contacts	RP19-PC-222	113-0264-7						

(Female contact)

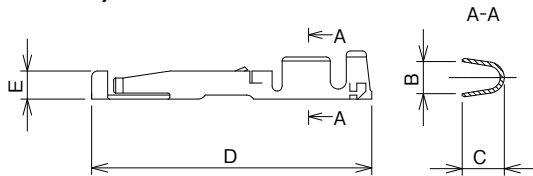

(The form shown above represents an example.)

For 13 and 15 contact positions

Type	Part No.	HRS No.	Plating	B	C	D	E	Applicable wire size
Loose piece contacts	RP13A-SC-121	113-0363-9	Partial gold plating	1.2	1.35	13.9	1.4	24 to 28 AWG
	RP13A-SC-122	113-0181-1	Silver plating					
Reel contacts	RP13A-SC-221	113-0362-6	Partial gold plating					
	RP13A-SC-222	113-0151-0	Silver plating					

13 contact position for super-thick wires (available for contact position numbers 12 and 13 only)

Type	Part No.	HRS No.	Plating	B	C	D	E	Applicable wire size
Loose piece contacts	RP13A-SC-112	113-0180-9	Silver plating	1.6	2.1	13.9	1.4	18 to 22 AWG
Reel contacts	RP13A-SC-212	113-0150-8						

For 20 contact positions

Type	Part No.	HRS No.	Plating	B	C	D	E	Applicable wire size
Loose piece contacts	RP19-SC-122	113-0270-0	Silver plating	1.2	1.35	11	1.18	24 to 30 AWG
Reel contacts	RP19-SC-222	113-0266-2						

(Note 1) Use connectors with gold-plated contacts if the connectors will be subjected to constant vibration.

(Note 2) Loose piece contacts are available in 100 piece packs. Reel contacts are available as 10,000 piece reels.

◆ Panel mounting hole dimensions

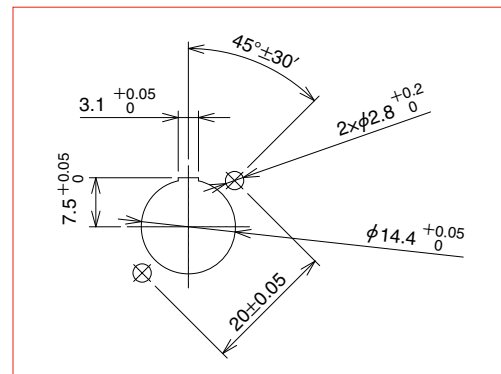

(Flange type)

● Applicable connector

Part No.	HRS No.
RP13A-12RA-13PC(71)	113-0183-7 71
RP13A-12RA-13PA(71)	113-0202-0 71
RP13A-12RA-15PC(71)	113-0207-3 71
RP13A-12RA-15PA(71)	113-1002-6 71
RP13A-12RA-20PC(71)	113-0215-1 71

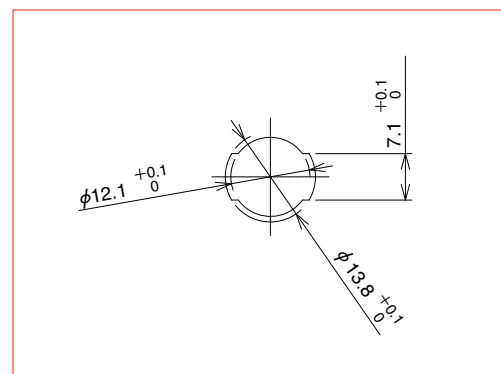

(Jam nut to be tightened)

● Applicable connector

Part No.	HRS No.
RP13A-12RB-13PA(71)	113-0203-2 71

(Note 1) Above figures show the arrangement viewed from the panel surface. The mating guide of flange type is located on the top position.

(Note 2) The applicable panel thickness for the flange type receptacle is 2.7mm max., since this type is mounted from the back surface of the panel.

(Note 3) The applicable panel thickness for a hex nut fastening type is 5mm max. and 1mm min.

## ■ RP13A anti-static type

### ● Plug

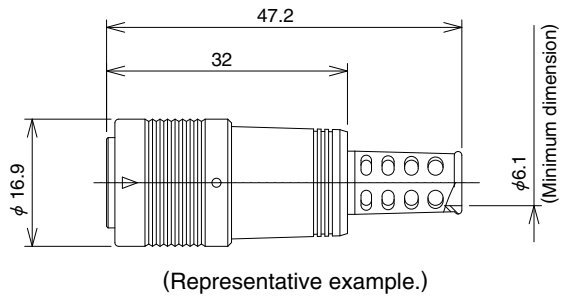

Part No.	HRS No.	No. of contacts	Weight
RP13A-12PA-13PC(71)	113-4003-5 71	13	6.0g

(Note) Cable clamping, cable rotation, and other forces may vary with the cable construction. Please make sure that your cable is suitable for use with these connectors before usage and production.

### ● Receptacle (flange type)

#### (Crimp type)

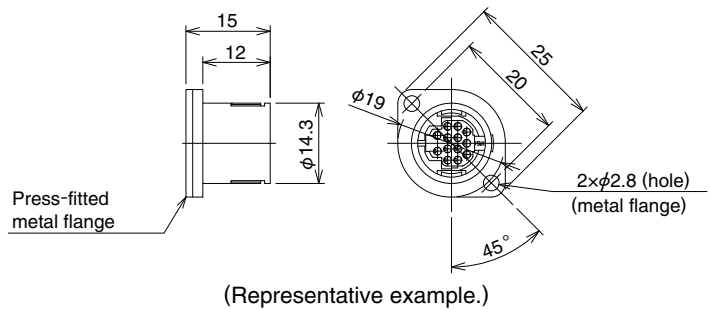

Part No.	HRS No.	No. of contacts	Weight
RP13A-12R-13SC(71)	113-4002-2 71	13	4.0g

(Remarks) See page 7 for details on mounting hole dimensions.

## ◆ Contact

### (Male contact)

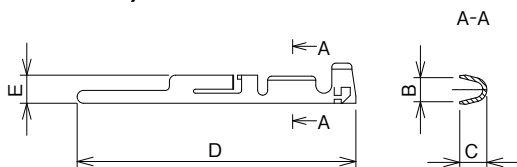

### (Female contact)

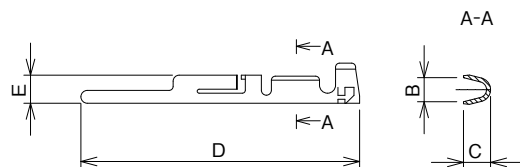

Type	Part No.	HRS No.	B	C	D	E	Applicable wire size
Loose piece contacts	RP19-PC-122	113-0268-8	1.2	1.35	12	1.18	24 to 30 AWG
Reel contacts	RP19-PC-222	113-0264-7					

Type	Part No.	HRS No.	B	C	D	E	Applicable wire size
Loose piece contacts	RP19-SC-122	113-0270-0	1.2	1.35	11	1.18	24 to 30 AWG
Reel contacts	RP19-SC-212	113-0265-0	1.6	2.1			18 to 22 AWG
	RP19-SC-222	113-0266-2	1.2	1.35			24 to 30 AWG

(Note 1) Loose piece contacts are available in 100 piece packs. Reel contacts are available as 10,000 piece reels.

Only contact positions 12 and 13 can be used with 18 to 20 AWG wire.

Other contact positions numbers cannot be used with this wire gauge.

(Note 2) When crimping wires gauge 18 to 22 AWG, make sure that the outer insulation diameter is  $\phi 1.79\text{mm}$  or less.

For wires gauges 24 to 30 AWG, use an outer insulation diameter of  $\phi 1.15$  or less.

### ◆ Panel mounting hole dimensions (for anti-static type)

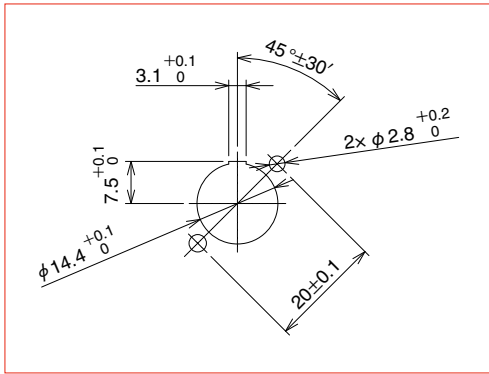

(Flange type)

(Note 1) Above figures show the arrangement viewed from the panel surface. The mating guide of flange type is located on top the position.

(Note 2) The applicable panel thickness for a flange type receptacle is maximum 4.7mm, as this type is mounted from the back surface of the panel.

### ◆ Dip post arrangement sizes for receptacles

#### ● Straight dip type

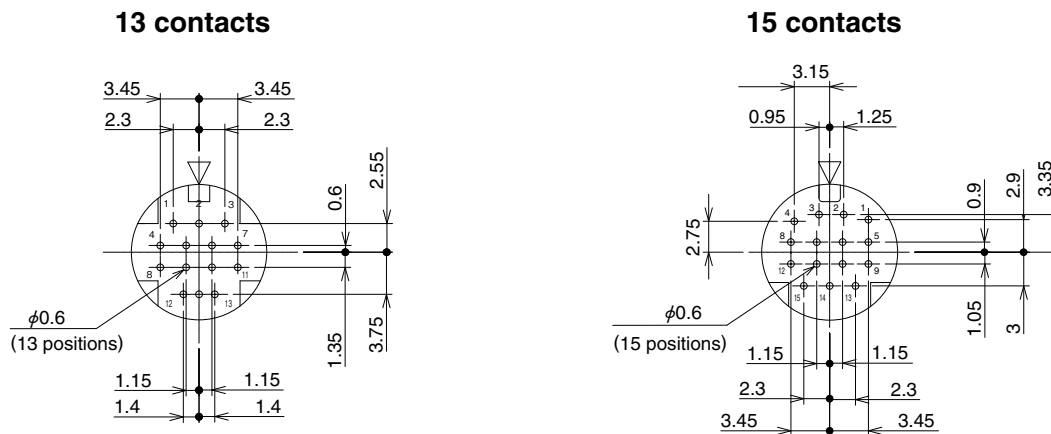

(Remarks) 1. The figures shown above for 13 and 15 contact positions are viewed from the receptacle mating end.  
2. A machining tolerance of  $\pm 0.05$  is recommended for the PCB layout dimensions.

#### ● Right-angle, dip type

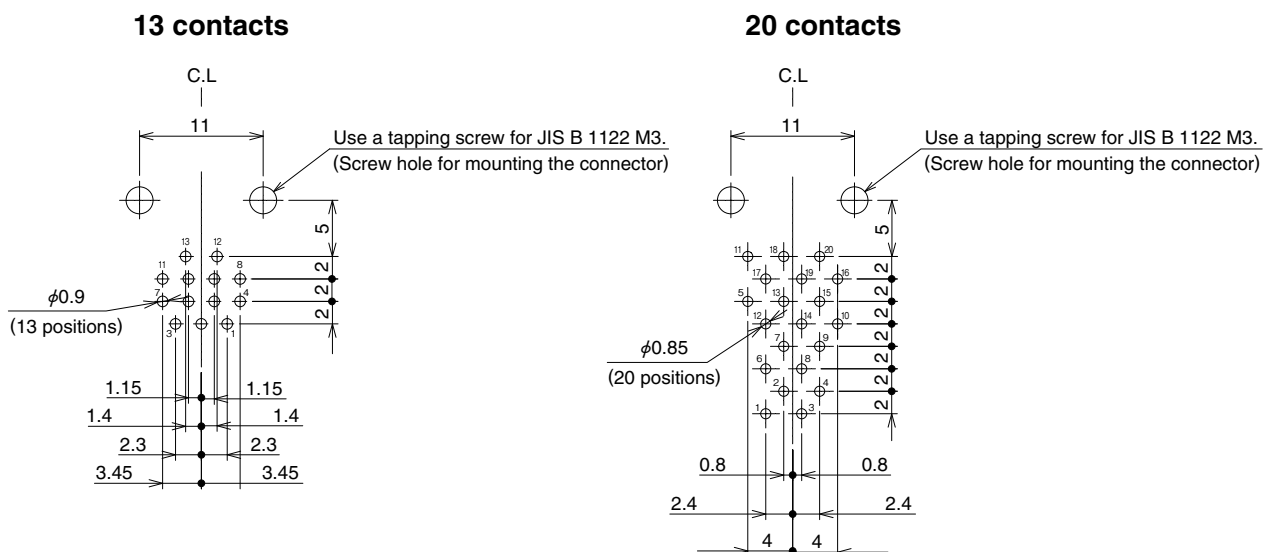

(Remarks) 1. The figures shown above are viewed from the contact insertion end.  
2. A machining tolerance of  $\pm 0.05$ mm is recommended for the PCB layout dimensions.



◆ Applicable tools

Type	Items	Part No.	HRS No.	Applicable contact	Applicable wire size and applicable cable diameter
Manual	Manual crimping tool	RP13-TC-11	150-0024-3	RP13-PC-112	18 to 22 AWG
		RP13-TC-12	150-0025-6	RP13-PC-121, 122	24 to 28 AWG
		RP13A-TC-11	150-0026-9	RP13A-SC-112	18 to 22 AWG
		RP13A-TC-12	150-0027-1	RP13A-SC-121, 122	24 to 28 AWG
		RP19-TC-11	150-0048-1	RP19-PC-112 RP19-SC-112	18 to 22 AWG
		RP19-TC-12		RP19-PC-122 RP19-SC-122	24 to 28 AWG
Auto	Automatic crimping press	CM-105C	901-0001-0	—————	—————
	Applicator	AP105-RP13-2	901-2024-0	RP13-PC-221, 222 RP13A-SC-221, 222	24 to 28 AWG
		AP105-RP19-1	901-2013-3	RP19-SC-212	18 to 22 AWG
		AP105-RP19-2	901-2014-6	RP19-PC-222 RP19-SC-222	24 to 28 AWG
Cable crimping tool		RP13A-TC-01	150-0070-0	—————	$\phi 4.6 \sim \phi 5.8$ $\phi 7 \sim \phi 7.5$
		RP13A-TC-02	150-0071-3	—————	$\phi 6.3, \phi 7.8$
Extraction tool		RP13-PC-TP	150-0021-5	Male contact	—————
		RP13A-SC-TP	150-0022-8	Female contact	—————
		RP6-SC-TP	150-0039-0	Male/female contact for RP19	—————

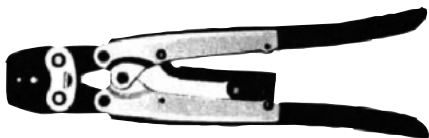

**RP13A-TC-02**  
Cable crimping tool  
(handle shape is shown as an example.)



**RP13-TC-11**  
Manual crimping tool

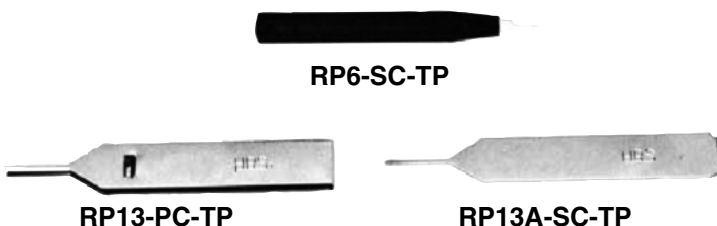

**Extraction tools**



**Automatic crimping press (Type CM-105C)**



## ◆ Termination/assembly procedure

### ● Plug

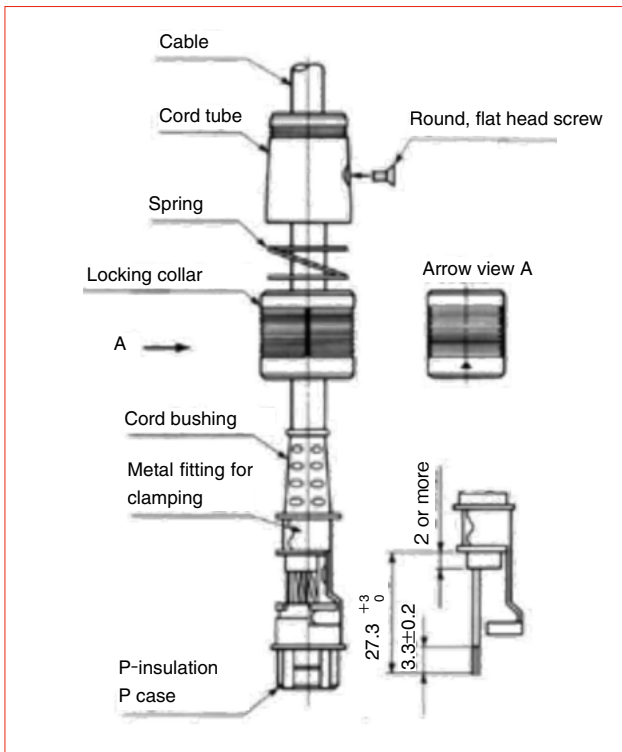

### ○ Assembly procedure

1. First, pass the terminated cable through the cord tube in the following order: spring, connection sleeve, and cord bushing, and then crimp and terminate the contacts.
2. Assemble the crimped and terminated contacts to the contact holes of the P-insulation P case. At this time, please make sure that the crimped contacts are securely engaged onto the contact holes of the P-insulation P case by lightly pulling the cable.
3. Attach the metal fitting by clamping to it the cord bushing and assemble these into the P-insulation P case. Then crimp the metal fitting by clamping it with the applicable tool.
4. Next, attach in the following order to the P-insulation P case: connection sleeve, spring, and cord. Then align the screw hole of the cord tube and that of the metal fitting for clamping, and tighten the round flat screw to the specified torque of 0.2 N·m (2 kg·cm).
5. After the assembly procedure described above has been completed, test the parts to make sure that the locking collar moves correctly.

## ◆ Contact Arrangement

### (Standard type)

Contact arrangement			
No. of contacts	13	15	20

### (Anti-static type)

Contact arrangement	
No. of contacts	13

(Remarks) 1. The figures shown above are viewed from the receptacle and jack mating end (plug connection end).

## ◆ Precautions

This product series uses silver plated contacts. Silver reacts easily to exposure to sulfur gas so the below conditions may cause tarnishing.

- Dusty environments
- Area with a high concentration area of gases such as sulfur dioxide gas, hydrogen sulfide gas, nitrogen dioxide gas and so on.  
Example; In close proximity to factory exhaust, automotive emissions, etc.
- Close to heaters, or in other areas marked by extreme temperature differences or high humidity.
- Close to rubber products includes rubber adhesives.

The Electrical connection is not affected by tarnishing on a silver surface due to the wiping effect of the contact pins.

### Storage

Packing state; Packed in original packing or equivalent container

Temperature -10 to +60°C

Humidity 85% Max

(It is recommended that the product be stored in an area of normal level of temperature and humidity, and free of any temperature fluctuation)

Please use this products within 6 months of delivery.

(After 6 month, please check the solderability before use)

“Storage” means long-term storage of the unused products in sealed packaging, prior to assembly to PCB.



**USA:**

**HIROSE ELECTRIC (U.S.A.), INC. HEADQUARTERS CHICAGO OFFICE**  
 2300 Warrenville Road, Suite 150,  
 Downers Grove, IL 60515  
 Phone : +1-630-282-6700  
<http://www.hirose.com/us/>

**USA:**

**HIROSE ELECTRIC (U.S.A.), INC. SAN JOSE OFFICE**  
 2841 Junction Ave, Suite 200  
 San Jose, CA. 95134  
 Phone : +1-408-253-9640  
 Fax : +1-408-253-9641  
<http://www.hirose.com/us/>

**USA:**

**HIROSE ELECTRIC (U.S.A.), INC. DETROIT OFFICE (AUTOMOTIVE)**  
 17197 N. Laurel Park Drive, Suite 253,  
 Livonia, MI 48152  
 Phone : +1-734-542-9963  
 Fax : +1-734-542-9964  
<http://www.hirose.com/us/>

**USA:**

**HIROSE ELECTRIC (U.S.A.), INC. BOSTON OFFICE**  
 300 Brickstone Square Suite 201,  
 Andover, MA 01810  
 Phone : +1-978-662-5255

**THE NETHERLANDS:**

**HIROSE ELECTRIC EUROPE B.V.**  
 Hogehillweg #8 1101 CC Amsterdam Z-0  
 Phone : +31-20-6557460  
 Fax : +31-20-6557469  
<http://www.hirose.com/eu/>

**GERMANY:**

**HIROSE ELECTRIC EUROPE B.V. GERMAN BRANCH**  
 Schoenbergstr. 20, 73760 ostfildern  
 Phone : +49-711-456002-1  
 Fax : +49-711-456002-299  
<http://www.hirose.com/eu/>

**GERMANY:**

**HIROSE ELECTRIC EUROPE B.V. NUREMBERG OFFICE**  
 Neumeyerstrasse 22-26, 90411 Nurnberg  
 Phone : +49-911 32 68 89 63  
 Fax : +49-911 32 68 89 69  
<http://www.hirose.com/eu/>

**GERMANY:**

**HIROSE ELECTRIC EUROPE B.V. HANOVER OFFICE**  
 Bayernstr. 3, Haus C 30855 Langenhagen, Germany  
 Phone : +49-511 97 82 61 30  
 Fax : +49-511 97 82 61 35  
<http://www.hirose.com/eu/>

**FRANCE:**

**HIROSE ELECTRIC EUROPE B.V. PARIS OFFICE**  
 130 Avenue Joseph Kessel, Bat E, 78960  
 Voisins le Bretonneux, France  
 Phone : +33-1-85764886  
 Fax : +33-1-85764823  
<http://www.hirose.com/eu/>

**UNITED KINGDOM:**

**HIROSE ELECTRIC EUROPE BV (UK BRANCH)**  
 4 Newton Court, Kelvin Drive, Knowlhill,  
 Milton Keynes, MK5 8NH  
 Phone : +44-1908 202050  
 Fax : +44-1908 202058  
<http://www.hirose.com/eu/>

**CHINA:**

**HIROSE ELECTRIC (CHINA) CO., LTD. (SHANGHAI, HEADQUARTERS)**  
 18, Enterprise Center Tower 2, 209# Gong He  
 Road, Jing'an District, Shanghai, CHINA 200070  
 Phone : +86-21-6391-3355  
 Fax : +86-21-6391-3335  
<http://www.hirose.com/cn/>

**CHINA:**

**HIROSE ELECTRIC (CHINA) CO.,LTD. BEIJING BRANCH**  
 A1001, Ocean International Center, Building 56# East 4th  
 Ring Middle Road, ChaoYang District, Beijing, 100025  
 Phone : +86-10-5165-9332  
 Fax : +86-10-5908-1381  
<http://www.hirose.com/cn/>

**CHINA:**

**HIROSE ELECTRIC (CHINA) CO., LTD. SHENZHEN BRANCH**  
 Room 09-13, 19/F, Office Tower Shun Hing Square, Di Wang Commercial Centre,  
 5002 Shen Nan Dong Road, Shenzhen City, Guangdong Province, 518008  
 Phone : +86-755-8207-0851  
 Fax : +86-755-8207-0873  
<http://www.hirose.com/cn/>

**HONG KONG:**

**HIROSE ELECTRIC HONGKONG TRADING CO., LTD.**  
 Room 1001, West Wing, Tsim Sha Tsui Centre, 66  
 Mody Road, Tsim Sha Tsui East, Kowloon, Hong Kong  
 Phone : +852-2803-5338  
 Fax : +852-2591-6560  
<http://www.hirose.com/hk/>

**TAIWAN:**

**HIROSE ELECTRIC TAIWAN CO., LTD.**  
 103 8F, No.87, Zhengzhou Rd., Taipei  
 Phone : +886-2-2555-7377  
 Fax : +886-2-2555-7355  
<http://www.hirose.com/tw/>

**KOREA:**

**HIROSE KOREA CO.,LTD.**  
 143, Gongdan 1-daero, Siheung-si,  
 Gyeonggi-do, 15084, Korea  
 Phone : +82-31-496-7000  
 Fax : +82-31-496-7100  
<http://www.hirose.co.kr/>

**SINGAPORE:**

**HIROSE ELECTRIC SINGAPORE PTE. LTD.**  
 03, Anson Road, #20-01, Springleaf Tower,  
 Singapore 079909  
 Phone : +65-6324-6113  
 Fax : +65-6324-6123  
<http://www.hirose.com/sg/>

**INDIA:**

**HIROSE ELECTRIC SINGAPORE PTE. LTD. DELHI LIAISON OFFICE**  
 Office NO.552, Regus-Green Boulevard, Level5, Tower C,  
 Sec62, Plot B-9A, Block B, Noida, 201301, Uttar Pradesh, India  
 Phone : +91-12-660-8018  
 Fax : +91-120-4804949  
<http://www.hirose.com/sg/>

**INDIA:**

**HIROSE ELECTRIC SINGAPORE PTE. LTD. BANGALORE LIAISON OFFICE**  
 Unit No-403, 4th Floor, No-84, Barton Centre, Mahatma  
 Gandhi (MG) Road, Bangalore 560 001, Karnataka, India  
 Phone : +91-80-4120 1907  
 Fax : +91-80-4120 9908  
<http://www.hirose.com/sg/>

**MALAYSIA:**

**PENANG REPRESENTATIVE OFFICE**  
 73-3-1, Ideal@The One, Jalan Mahsuri, Bayan  
 Lepas Penang, 11950, Malaysia  
 Phone : +604-648-5536  
<http://www.hirose.com/sg/>

**THAILAND:**

**BANGKOK OFFICE (REPRESENTATIVE OFFICE)**  
 Unit 4703, 47th FL., 1 Empire Tower, South Sathorn  
 Road, Yannawa, Sathorn, Bangkok 10120 Thailand  
 Phone : +66-2-686-1255  
 Fax : +66-2-686-3433  
<http://www.hirose.com/sg/>



**HIROSE ELECTRIC CO.,LTD.**

2-6-3,Nakagawa Chuoh,Tsuzuki-Ku,Yokohama-Shi 224-8540,JAPAN  
 TEL: +81-45-620-3526 Fax: +81-45-591-3726  
<http://www.hirose.com>  
<http://www.hirose-connectors.com>