

RSKT-MFS1/4
RS_Stock_No: 5021232



Resistance Range (Ω)	10 Ω to 1M Ω
Dimensions	1.7 Dia. x 3.4 mm
Tolerance	$\pm 1\%$
Power Rating	0.25 W
Temperature Coefficient	± 50 ppm/ $^{\circ}$ C
Number of each resistor	20

No	Manufacturer part number	Resistance
1	MFS1/4CC10R0F	10 Ω
2	MFS1/4CC11R0F	11 Ω
3	MFS1/4CC12R0F	12 Ω
4	MFS1/4CC13R0F	13 Ω
5	MFS1/4CC15R0F	15 Ω
6	MFS1/4CC16R0F	16 Ω
7	MFS1/4CC18R0F	18 Ω
8	MFS1/4CC20R0F	20 Ω
9	MFS1/4CC22R0F	22 Ω
10	MFS1/4CC24R0F	24 Ω
11	MFS1/4CC27R0F	27 Ω
12	MFS1/4CC30R0F	30 Ω
13	MFS1/4CC33R0F	33 Ω
14	MFS1/4CC36R0F	36 Ω
15	MFS1/4CC39R0F	39 Ω
16	MFS1/4CC43R0F	43 Ω
17	MFS1/4CC47R0F	47 Ω
18	MFS1/4CC51R0F	51 Ω
19	MFS1/4CC56R0F	56 Ω
20	MFS1/4CC62R0F	62 Ω
21	MFS1/4CC68R0F	68 Ω
22	MFS1/4CC75R0F	75 Ω
23	MFS1/4CC82R0F	82 Ω
24	MFS1/4CC91R0F	91 Ω
25	MFS1/4CC1000F	100 Ω
26	MFS1/4CC1100F	110 Ω
27	MFS1/4CC1200F	120 Ω
28	MFS1/4CC1300F	130 Ω
29	MFS1/4CC1500F	150 Ω
30	MFS1/4CC1600F	160 Ω
31	MFS1/4CC1800F	180 Ω
32	MFS1/4CC2000F	200 Ω
33	MFS1/4CC2200F	220 Ω
34	MFS1/4CC2400F	240 Ω
35	MFS1/4CC2700F	270 Ω
36	MFS1/4CC3000F	300 Ω
37	MFS1/4CC3300F	330 Ω
38	MFS1/4CC3600F	360 Ω
39	MFS1/4CC3900F	390 Ω
40	MFS1/4CC4300F	430 Ω
41	MFS1/4CC4700F	470 Ω
42	MFS1/4CC5100F	510 Ω
43	MFS1/4CC5600F	560 Ω
44	MFS1/4CC6200F	620 Ω
45	MFS1/4CC6800F	680 Ω
46	MFS1/4CC7500F	750 Ω
47	MFS1/4CC8200F	820 Ω
48	MFS1/4CC9100F	910 Ω
49	MFS1/4CC1001F	1 k Ω
50	MFS1/4CC1101F	1.1 k Ω

No	Manufacturer part number	Resistance
51	MFS1/4CC1201F	1.2 k Ω
52	MFS1/4CC1301F	1.3 k Ω
53	MFS1/4CC1501F	1.5 k Ω
54	MFS1/4CC1601F	1.6 k Ω
55	MFS1/4CC1801F	1.8 k Ω
56	MFS1/4CC2001F	2 k Ω
57	MFS1/4CC2201F	2.2 k Ω
58	MFS1/4CC2401F	2.4 k Ω
59	MFS1/4CC2701F	2.7 k Ω
60	MFS1/4CC3001F	3 k Ω
61	MFS1/4CC3301F	3.3 k Ω
62	MFS1/4CC3601F	3.6 k Ω
63	MFS1/4CC3901F	3.9 k Ω
64	MFS1/4CC4301F	4.3 k Ω
65	MFS1/4CC4701F	4.7 k Ω
66	MFS1/4CC5101F	5.1 k Ω
67	MFS1/4CC5601F	5.6 k Ω
68	MFS1/4CC6201F	6.2 k Ω
69	MFS1/4CC6801F	6.8 k Ω
70	MFS1/4CC7501F	7.5 k Ω
71	MFS1/4CC8201F	8.2 k Ω
72	MFS1/4CC9101F	9.1 k Ω
73	MFS1/4CC1002F	10 k Ω
74	MFS1/4CC1102F	11 k Ω
75	MFS1/4CC1202F	12 k Ω
76	MFS1/4CC1302F	13 k Ω
77	MFS1/4CC1502F	15 k Ω
78	MFS1/4CC1602F	16 k Ω
79	MFS1/4CC1802F	18 k Ω
80	MFS1/4CC2002F	20 k Ω
81	MFS1/4CC2202F	22 k Ω
82	MFS1/4CC2402F	24 k Ω
83	MFS1/4CC2702F	27 k Ω
84	MFS1/4CC3002F	30 k Ω
85	MFS1/4CC3302F	33 k Ω
86	MFS1/4CC3602F	36 k Ω
87	MFS1/4CC3902F	39 k Ω
88	MFS1/4CC4302F	43 k Ω
89	MFS1/4CC4702F	47 k Ω
90	MFS1/4CC5102F	51 k Ω
91	MFS1/4CC5602F	56 k Ω
92	MFS1/4CC6202F	62 k Ω
93	MFS1/4CC6802F	68 k Ω
94	MFS1/4CC7502F	75 k Ω
95	MFS1/4CC8202F	82 k Ω
96	MFS1/4CC9102F	91 k Ω
97	MFS1/4CC1003F	100 k Ω
98	MFS1/4CC1103F	110 k Ω
99	MFS1/4CC1203F	120 k Ω
100	MFS1/4CC1303F	130 k Ω

No	Manufacturer part number	Resistance
101	MFS1/4CC1503F	150 k Ω
102	MFS1/4CC1603F	160 k Ω
103	MFS1/4CC1803F	180 k Ω
104	MFS1/4CC2003F	200 k Ω
105	MFS1/4CC2203F	220 k Ω
106	MFS1/4CC2403F	240 k Ω
107	MFS1/4CC2703F	270 k Ω
108	MFS1/4CC3003F	300 k Ω
109	MFS1/4CC3303F	330 k Ω
110	MFS1/4CC3603F	360 k Ω
111	MFS1/4CC3903F	390 k Ω
112	MFS1/4CC4303F	430 k Ω
113	MFS1/4CC4703F	470 k Ω
114	MFS1/4CC5103F	510 k Ω
115	MFS1/4CC5603F	560 k Ω
116	MFS1/4CC6203F	620 k Ω
117	MFS1/4CC6803F	680 k Ω
118	MFS1/4CC7503F	750 k Ω
119	MFS1/4CC8203F	820 k Ω
120	MFS1/4CC9103F	910 k Ω
121	MFS1/4CC1004F	1 M Ω

MF 塗装絶縁形金属皮膜固定抵抗器 Coat-Insulated Fixed Metal Film Resistors

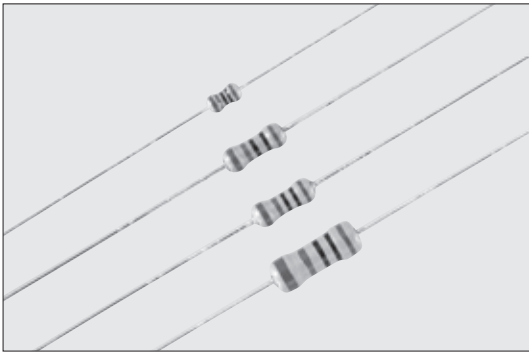

外装色：ライトグレー Coating color : Light gray
表示：カラーコード Marking : Color code

■構造図 Construction

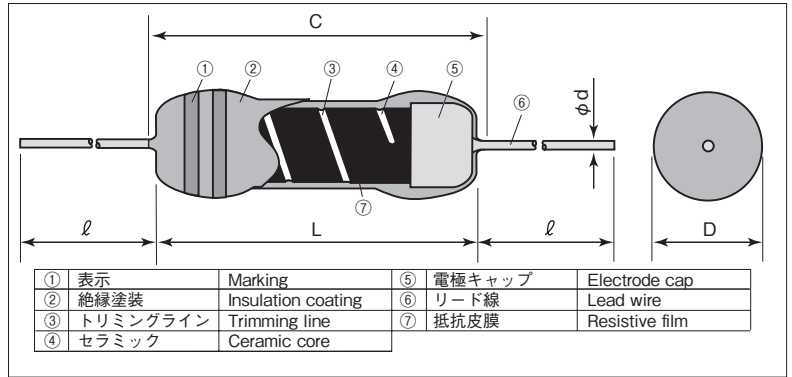

■特長 Features

- 高精度、低T.C.R.の金属皮膜抵抗です。
- 自動挿入が可能です。
- 各種フォーミングが可能です。
- 長期安定性が優れています。
- 欧州RoHS対応品です。
- High precision and low T.C.R. metal film resistors.
- Automatic insertion is applicable.
- Various formings are available.
- Excellent stability for a long time.
- Products meet EU-RoHS requirements.

■外形寸法 Dimensions

形名 Type	寸法 Dimensions (mm)				Weight(g) (1000pcs)
	L	C Max.	D	d(Nominal)	
MFS1/4	3.2±0.2	3.4	1.7 ^{+0.2} _{-0.1}	0.45	120
MF1/4	6.3±0.5	7.1	2.3±0.3	0.6	215
MFS1/2					215
MF1/2	9.0±1.0	11.1	3.5±0.4		360

※ テーピング及びフォーミングによってリード寸法が異なります。
※ Lead length changes depending on taping and forming type.

■参考規格 Reference Standards

IEC 60115-1
JIS C 5201-1
EIAJ RC-2137

■品名構成 Type Designation

例 Example

MF	1/4	D	C	T52	A	1002	F
品種 Product Code	定格電力 Power Rating	抵抗温度係数 T.C.R. (×10 ⁻⁶ /K)	端子表面材質 Terminal Surface Material	二次加工 Taping & Forming	包装 Packaging	公称抵抗値 Nominal Resistance	抵抗値許容差 Resistance Tolerance
	S1/4: 0.25W 1/4: 0.25W S1/2: 0.5W 1/2: 0.5W	C: ±50 D: ±100 L: ±200	C: SnCu	下記参照 See table below	A: アモバック A: AMMO R: リール R: REEL	D, F: 4 digits G: 3 digits	D: ±0.5% F: ±1% G: ±2%

環境負荷物質含有についてEU-RoHS以外の物質に対するご要求がある場合にはお問合せください。
テーピング及びフォーミングの詳細については巻末のAPPENDIX Cを参照してください。

Contact us when you have control request for environmental hazardous material other than the substance specified by EU-RoHS.
For further information on taping and forming, please refer to APPENDIX C on the back pages.

■二次加工対応表 Taping & Forming Matrix

形名 Type	アキシャルテーピング Axial Taping		ラジアルテーピング Radial Taping				Uフォーミング U Forming	Mフォーミング M Forming				
	T26	T52	VT	VTP	VTE	MT	U	M5		M10	M12.5	M15
MFS1/4□C	○	○	○	—	—	○	○	M5F	M5R	—	—	—
MF1/4□C	○	○	○	○	○	—	○	—	—	M10F	M12.5R	—
MFS1/2□C	○	○	○	○	○	—	—	—	—	M10R	—	—
MF1/2□C	—	○	—	—	—	—	—	—	—	—	M12.5R	M15R

□ : T.C.R.

■定格 Ratings

形名 Type	定格電力 Power Rating	抵抗温度係数 T.C.R. (×10 ⁻⁶ /K)	抵抗値範囲 Resistance Range (Ω)			最高使用電圧 Max. Working Voltage	最高過負荷電圧 Max. Overload Voltage	耐電圧 Dielectric Withstanding Voltage	テーピングと 包装数/アモバック Taping & Q'ty/AMMO (pcs)	
			D: 0.5% E24 · E192	F: ±1% E24 · E96	G: ±2% E24				T26A	T52A
MFS1/4CC	0.25W	C: ±50	49.9~562k	10~1M	—	250V	500V	300V	3,000	3,000
MFS1/4DC		D: ±100							3,000	3,000
MF1/4CC	0.25W	C: ±50	10~2.21M	10~2.21M	—	250V	500V	500V	2,000	2,000
MF1/4DC		D: ±100							2,000	2,000
MF1/4LC	0.25W	L: ±200	—	1.0~10	0.51~10	250V	500V	500V	2,000	2,000
MFS1/2CC		C: ±50	10~1M	10~2.2M	10~2.2M				350V	700V
MFS1/2DC	D: ±100	2,000				2,000				
MF1/2CC	0.5W	C: ±50	10~5.05M	10~4.99M	—	350V	700V	700V	—	2,000
MF1/2DC		D: ±100								2,000
MF1/2LC	0.5W	L: ±200	—	1.0~10	0.51~10	350V	700V	700V	—	2,000
MF1/2LC		L: ±200	2,000							

定格周囲温度 Rated Ambient Temperature : +70°C

使用温度範囲 Operating Temperature Range : -55°C ~ +155°C

定格電圧は、√定格電力×公称抵抗値による算出値、又は表中の最高使用電圧のいずれか小さい値が定格電圧となります。

Rated voltage = √Power Rating × Resistance value or Max. working voltage, whichever is lower.

本カタログに掲載の仕様は予告なく変更する場合があります。ご注文およびご使用前に納入仕様書で内容をご確認ください。
車載機器、医療機器、航空機器など人命に関わったり、あるいは甚大な損害を引き起こす可能性のある機器へのご使用を検討される場合には、必ず事前にご相談ください。
Specifications given herein may be changed at any time without prior notice. Please confirm technical specifications before you order and/or use.
Contact our sales representatives before you use our products for applications including automobiles, medical equipment and aerospace equipment.
Malfunction or failure of the products in such applications may cause loss of human life or serious damage.

■負荷軽減曲線 Derating Curve

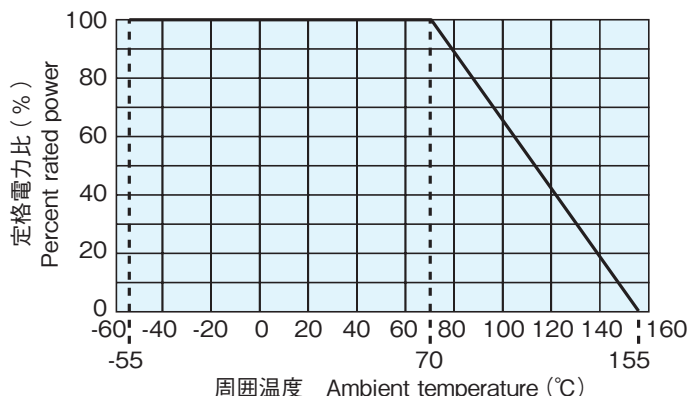

周囲温度70℃以上で使用される場合は、上図負荷軽減曲線に従って、定格電力を軽減して御使用ください。

For resistors operated at an ambient temperature of 70℃ or above, a power rating shall be derated in accordance with the above derating curve.

■性能 Performance

試験項目 Test Items	規格値 Performance Requirements $\Delta R \pm (\% + 0.05\Omega)$		試験方法 Test Methods
	保証値 Limit	代表値 Typical	
抵抗値 Resistance	規定の許容差内 Within specified tolerance	—	25℃
抵抗温度係数 T.C.R.	規定値内 Within specified T.C.R.	—	+25℃ / +125℃
過負荷 (短時間) Overload (Short time)	0.5	0.3	定格電圧×2.5倍又は最高過負荷電圧の低い方を5秒印加：MFS1/4, MF1/4, MF1/2 定格電圧×2倍又は最高過負荷電圧の低い方を5秒印加：MFS1/2 Rated voltage×2.5 or Max. overload vol., whichever is lower, for 5s：MFS1/4, MF1/4, MF1/2 Rated voltage×2 or Max. overload vol., whichever is lower, for 5s：MFS1/2
はんだ耐熱性 Resistance to soldering heat	0.75：MFS1/4 0.5：MF1/4, MFS1/2, MF1/2	0.4：MFS1/4 0.25：MF1/4, MFS1/2, MF1/2	260℃±5℃, 10s±1s
温度急変 Rapid change of temperature	1.0	0.3	-55℃ (30min.) / +155℃ (30min.) 5 cycles
耐湿負荷 Moisture resistance	1.5：MFS1/4 1：MF1/4, MFS1/2, MF1/2	1：MFS1/4 0.75：MF1/4, MFS1/2, MF1/2	40℃±2℃, 90%~95%RH, 1000h 1.5時間 ON / 0.5時間 OFFの周期 1.5h ON / 0.5h OFF cycle
70℃での耐久性 Endurance at 70℃	1.5：MFS1/4 1：MF1/4, MFS1/2, MF1/2	1：MFS1/4 0.75：MF1/4, MFS1/2, MF1/2	70℃±2℃, 1000h 1.5時間 ON / 0.5時間 OFFの周期 1.5h ON / 0.5h OFF cycle

■使用上の注意 Precautions for Use

- 本製品及び実装したプリント基板にフラックス等によるイオン性不純物質が付着していると、耐湿性・耐腐食性等の点から好ましくありません。フラックス内には、塩素・酸等のイオン性物質が含まれている場合があります。これらのイオン性物質を除去するためには洗浄を行ってください。特に鉛フリーはんだを御使用の場合、濡れ性向上の為、イオン性物質を多く含有している場合があります。RMA系のはんだ又はフラックスをご使用になるか、十分な洗浄を行ってください。また、保管環境や実装条件・環境等によって、汗、塩等のイオン性物質を付着させた場合も、耐湿性・耐腐食性等の点から好ましくありません。その汚染時に対しましてもこれらのイオン性物質を除去するために洗浄を行ってください。
- Ionic impurities such as flux etc. that are attached to these products or those mounted onto a PCB, negatively affect their moisture resistance, corrosion resistance, etc. The flux may contain ionic substances like chlorine, acid, etc. Please wash them to get rid of these ionic substances especially when using lead-free solder that may contain much of the said substances for improving a wetting characteristic. Using RMA solder or RMA flux, or well-washing is needed. Also, attaching ionic substances such as perspiration, salt etc. by storage environments or mounting conditions/environments negatively affects their moisture resistance, corrosion resistance etc. Please wash them to remove the ionic substances when they are polluted.