

REVISIONS			
REV	DESCRIPTION	DATE	BY

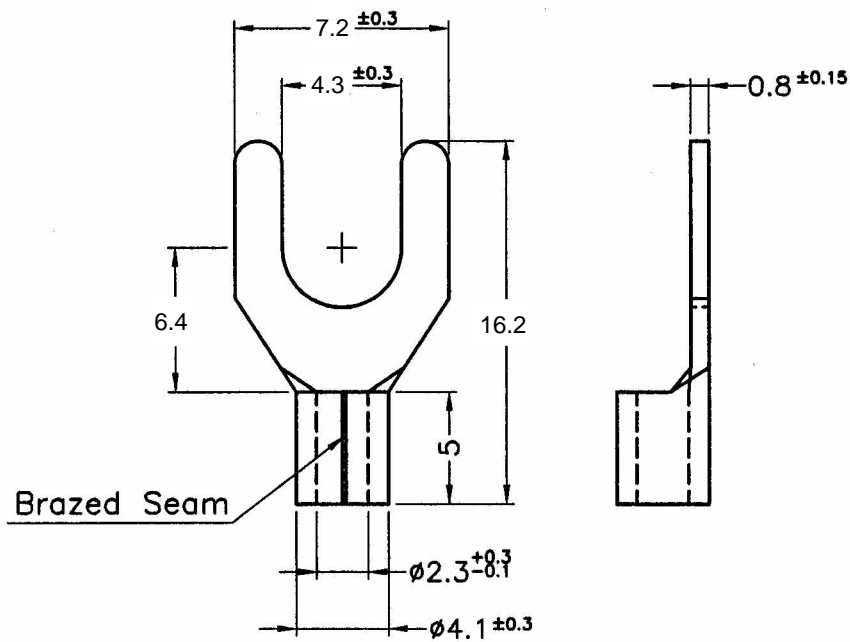

PART NO.	A	W	L	F
SNB2-3.2	3.2	5.7	16.2	6.4
SNBS2-3.7	3.7	5.7	16.2	6.4
SNBL2-3.7	3.7	6.0	16.2	6.4
SNBS2-4	4.3	6.4	16.2	6.4
SNBM2-4	4.3	7.2	16.2	6.4
SNBL2-4	4.3	8.1	16.2	6.4
SNBS2-5	5.3	8.1	16.2	6.4
SNBL2-5	5.3	9.5	16.2	6.4
SNBL2-6	6.4	12.0	22.2	11.2

MAXIMUM ELECTRIC CURRENT: 27 AMPERE (16-14 A.W.G)

PART NUMBER <b>SEE ABOVE</b>				TITLE <b>Y型裸端子</b>		<b>產品規格圖面</b>	
				MATERIAL <b>COPPER</b>		DATE <b>1998.12.21</b>	
				FINISH <b>TIN PLATING</b>		DRAWN <b>JASON</b>	
				COLOR 		CHECK 	
DRAWING NUMBER <b>SNB2-H</b>		UNLESS OTHERWISE SPECIFIED TOLERANCE <b>±1.0</b>		APPROVED 			
SIZE <b>A4</b>	SCALE <b>NONE</b>	UNIT <b>mm</b>	REV <b>A</b>				