

承 认 书

APPROVED SHEET

产品名称: SPEAKER

客户料号: _____

规 格: 50MM 8Ω

产品编号: T50 圆形外磁纸盆 -080RP

日 期: _____

样品编号: _____

客户承认		意见	

顾客 CUSTOMER		口径: 50MM SIZE	送样日期 DATE
型号 PART NO.	顾客型名 CUSTOMER'S NO		
	样品编号 SAMPLE NO		
P	制 品 规 格 SPECIFICATION		
编 号	项 目	规 格	测 试 条 件
1	公称交流阻值 VOICE COIL IMP	8 Ω ± 15%	AT 500HZ 1.0V
2	动 作 OPERATION	无异常发生 MUST BE NORMAL	2. V SINE WAVE
3	异 常 音 BUZZES &	无异常发生 MUST BE NORMAL	2. V SINE WAVE
4	最低共振周波数 RESONATFREQ..F	400HZ ± 20%	INPUT 1..0V
5	出力音压基准 OUT-PUT S-P-L	79db ± 2dB	INPUT 1.0W 1.0M AT 300. 600 . 900. 1200
6	实效周波带域 FREQ.RESPONSE	Fo 20KHZ ± 20	S.P.L -10db
7	定格周波数带域 RATED POWER INPUT	HZ	
8	定格入力 RATED .RFEQ.RESP.	0.5W	
9	最大入力 MAX.POWER INPUT	1W	
10	连续负荷 LOAD TEST	AFTER TEST MEET 7 & 8	WHITE NOISE 0.5W 96HOURS
11	耐热试验 HEAT TEST	AFTER TEST MEET 7 8	70℃ ± 2℃ 相对湿度 20-25% 8HOURS
12	耐湿试验 HUMIDITY TEST	AFTER TEST MEET 7 8	40℃ ± 2℃ 相对湿度 90-95% 8HOURS
13	耐寒试验 COLI TEST	AFTER TEST MEET 7 8	-20℃ ± °C 8HOURS
14	磁束密度 FLUX DENSITY	GAUSS 以上	
15	磁铁 MAGNET	铁氧体 32*16*8	
16	重量 WEIGNET		
17	高度 LIGHT	MM	
18	冲击试验 SHOCK TEST	AFTER TEST MEET 7 & 8	The loud speaker shall bedropped 10 times
19	失真率 DISTORTION	5% 以下	INPUT 1.0V 1000HZ
20	绝缘阻值	1.0M Ω 以上	端子与支架间
DESIGNED BY:		CHECKED BY	APPROVED

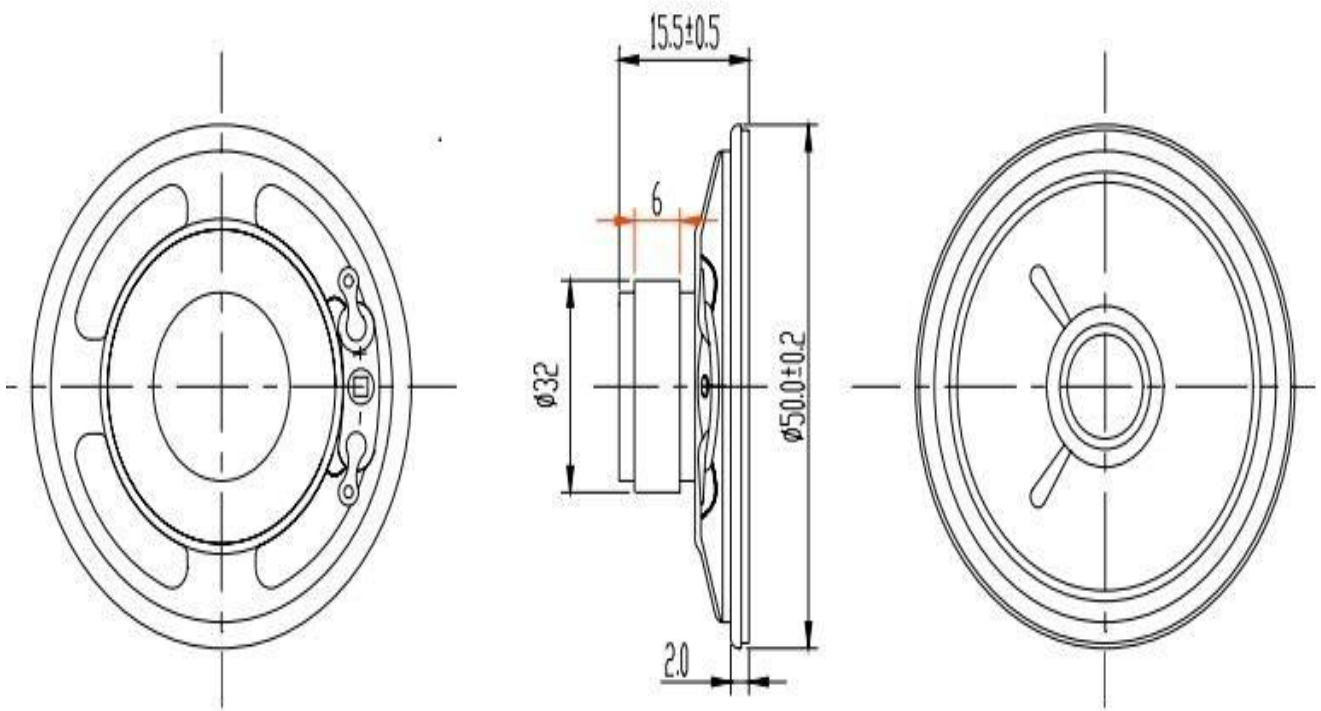

Impedance vs Freq

