

Revision : 03

Approval Sheet

CUSTOMER: AC48





CUSTOMER MODEL NO.: _____

MODEL NO.: SPS0502E2-T

PART NO.: 3A-101WX05-068

DESCRIPTION: Switching Power Supply

DATE: 2012-6-12

PREPARED	DESIGNED	CHECKED	APPROVED
			

APPROVAL DATE:

CUSTOMER APPROVAL		

1 Product Characteristics:

1.1 General Description

Model _____ is a universal switching-mode power supply, operating at input voltage 90VAC to 255VAC and output voltage of 5VDC with 2.0A DC load

1.2 Electric Characteristics

1.2.1 Input

No	ITEM	SPECIFICATION
1.	Rated input Voltage	AC100V-240V
	Vibration input Voltage Range	AC90V-255V
2.	Frequency Rated	50-60Hz
	Frequency Vibration	47-63Hz
3.	Input Rated Current	300mA RMS Max
	Inrush Current	15A Max .at 115vac cool start
		30A Max .at 230vac cool start
4.	Leakage current	0.25mA
5.	Efficiency	60% Min.

1.2.2 Output:

No	ITEM	SPECIFICATION
1.	output Voltage	5VDC
2.	output max. current	2.0A
3.	output min. Current	0A
4.	Line regulation	± 1%
5.	Output voltage tolerance	± 5%
6.	Over voltage protection	6.46V to 7.14V DC(output shut down)
7.	Short circuit protection	Output shut down and auto restart
8.	Ripple Voltage (L.F.)	150mV (p-p) (100V-240VAC at full load)

1.2.3 HI-POT SPECIFICATION

Input to output : 3000VAC 10mA 1 minute.

1.2.4 Insulation resistance:

Input to output: 500vdc to test the input to output resistance not be less 100M ohm

1.2.5 Safety approved: PSE,UL,CUL**1.2.6 EMI standard : meet EN55022 B****1.2.7 PB-free standard: RoHS Compliant**

1.3 Mechanical Characteristics

1.3.1 AC plug: Direct plug-In UL Type.

1.3.2 DC cord:

(1)Bending test: Life 1000 times 100% guarantee. Swings 120 from

Left to right loading weight 200g , 40 cycle/minute.

(2)Pull test : DC cord and plug ,weight 6kg for 1 minute.

1.3.3 Cord length and output plug: See Reference Att.4

1.3.4 Weight : 113 g

1.3.5 Case Size: (L)60 X (W) 44 X (H) 25mm

1.3.6 Normal operating temperature and humidity

1.3.7 Temperature

Operating: 0°C to 40°C

Storage : -10°C to 70°C

1.3.8 Humidity

Operating : 20% to 80%.

Storage: 10% to 90%

2.Attachment:

- (Att.1) Label**
- (Att.2) Outdrawing**
- (Att.3) Package**
- (Att.3.1) Package flow chart**
- (Att.4) DC cord drawing**
- (Att.5) Electrical test report**

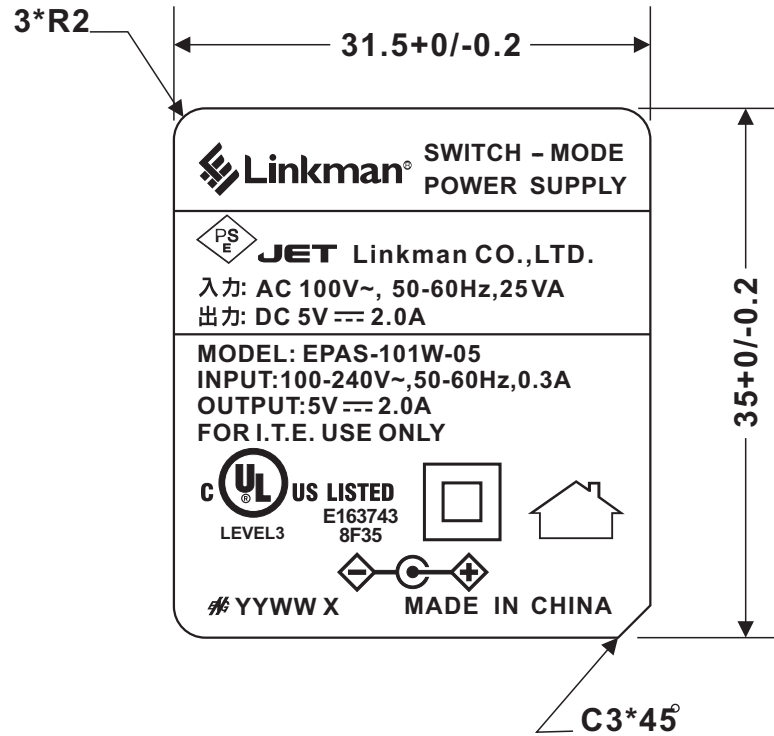

UNIT: mm

YYWW X YY:YEAR WW:WEEK X=S or A(S:FU YONG A:DONG GUAN)

ALUMINUM NAMEPLATE: ○ BLACK WORD ON SILVER BASE 銀底黑字
鋁板

○ SILVER WORD ON BLACK BASE 黑底銀字

METALIZED POLYESTER: ○ BLACK WORD ON SILVER BASE 銀底黑字
消銀龍

(SILVER MATTE) ● SILVER WORD ON BLACK BASE 黑底銀字

3A-101WX05-068

TOLERANCE				

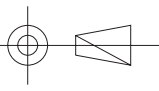
DESIGNED	CHECKED	APPROVED		TITLE	DATE
Tanll	Liujin	LNB		UNITS	LABEL
			mm	DRAWING No.	
			SCALE	@N20-AC4800-A01	12/06/12
			2:1	DRAWING NAME	REVISION
				1002	02

Att.2

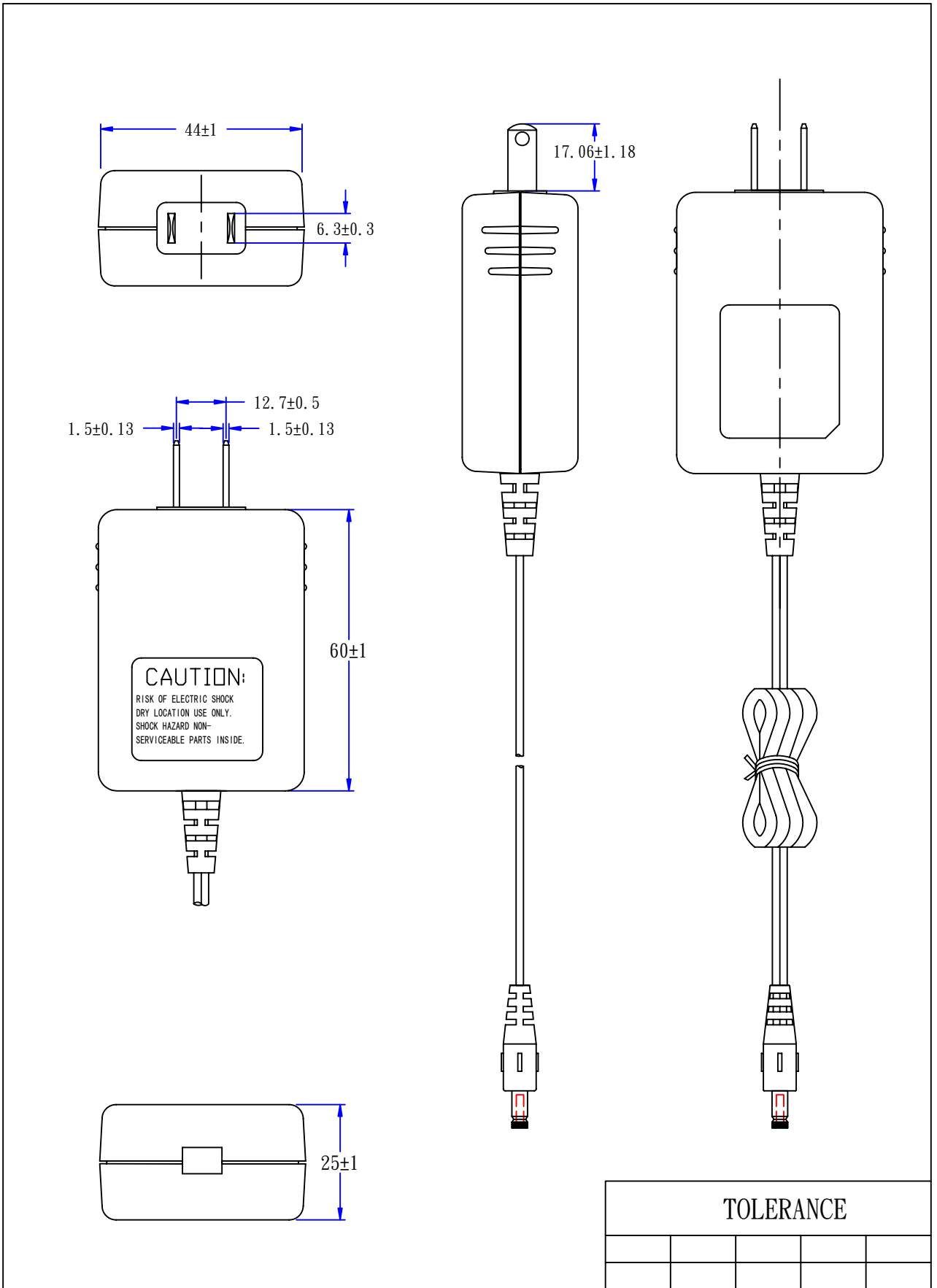

TOLERANCE				

DESIGNED	CHECKED	APPROVED		TITLE	OUTDRAWING	DATE
Hump	Zhou jg	Bi ll		UNITS	DRAWING No.	SPS0502E2-T
			SCALE	DRAWING NAME	100201	REVISION
						01

Att.3

CARTON MATERIAL:A=B(6mm)

CARTON SIZE:388X380X245mm

外箱尺寸 388X380X245mm

Q'TY: 80PCS(20*4)

數量 80PCS(20*4)

N.W: 8.96KGS

G.W: 9.76KGS

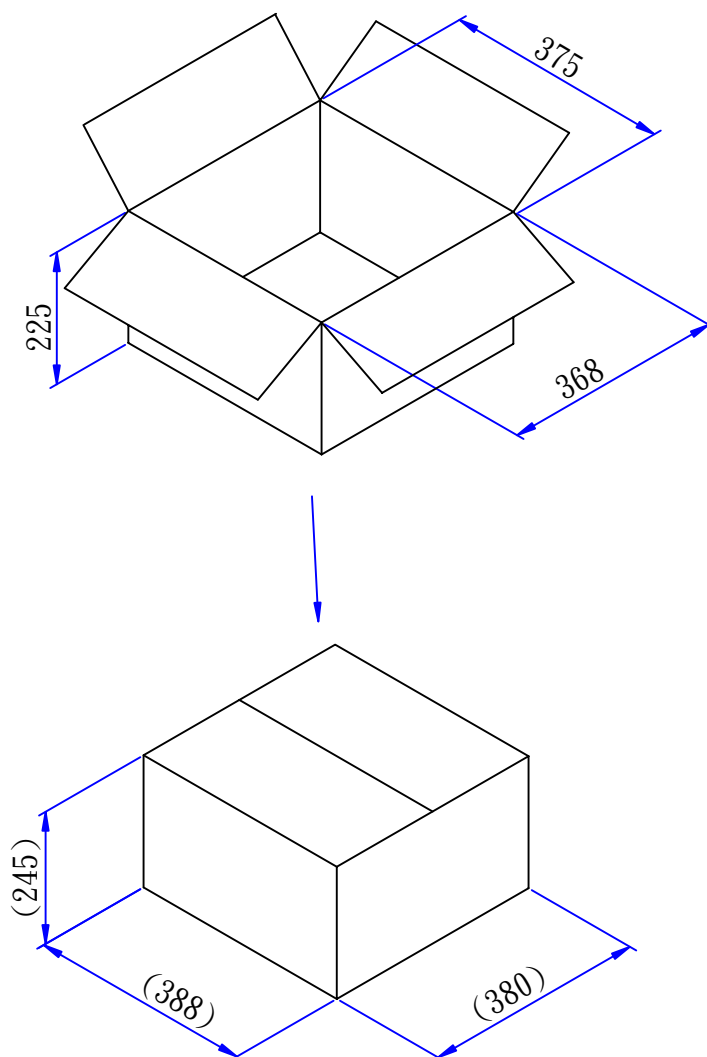

The tolerance of the internal dimensions of the carton is +7/-0

紙箱內度尺寸公差為+7/-0

TOLERANCE				

DESIGNED	CHECKED	APPROVED			TITLE	DATE
Hump	Zhou jg	Bi ll	UNITS	mm	PACKAGE DRAWING No. P36-2040-H-50	07/01/11
			SCALE			
					DRAWING NAME	REVISION
					36-2040-H-50	02

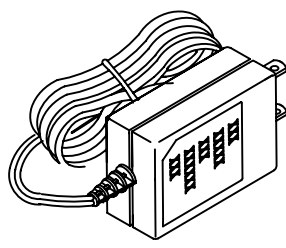

← Product

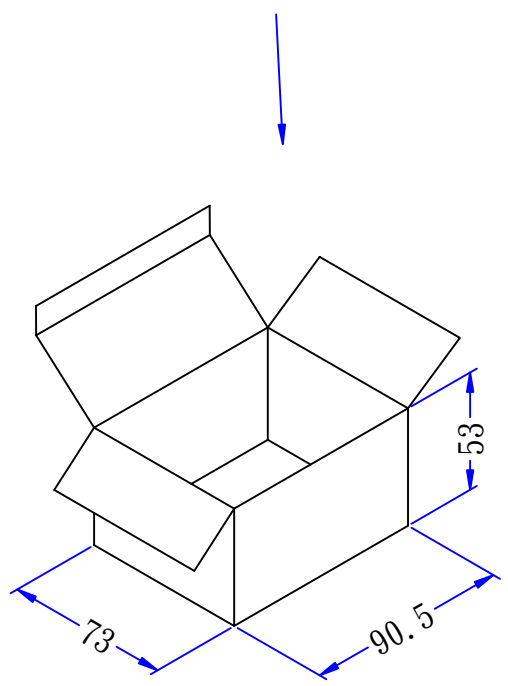

← WHITE BOX:36#

The tolerance of the external dimensions of the white box is ± 1
 小禮盒外度尺寸公差為 ± 1

TOLERANCE				

DESIGNED	CHECKED	APPROVED			TITLE	DATE
Hump	Zhoujg	Bill	UNITS	mm	PACKAGE FLOW CHART	
			SCALE		DRAWING No.	07/01/11
					SPS0502E2-T	
					DRAWING NAME	REVISION
					36#	01

Att.4

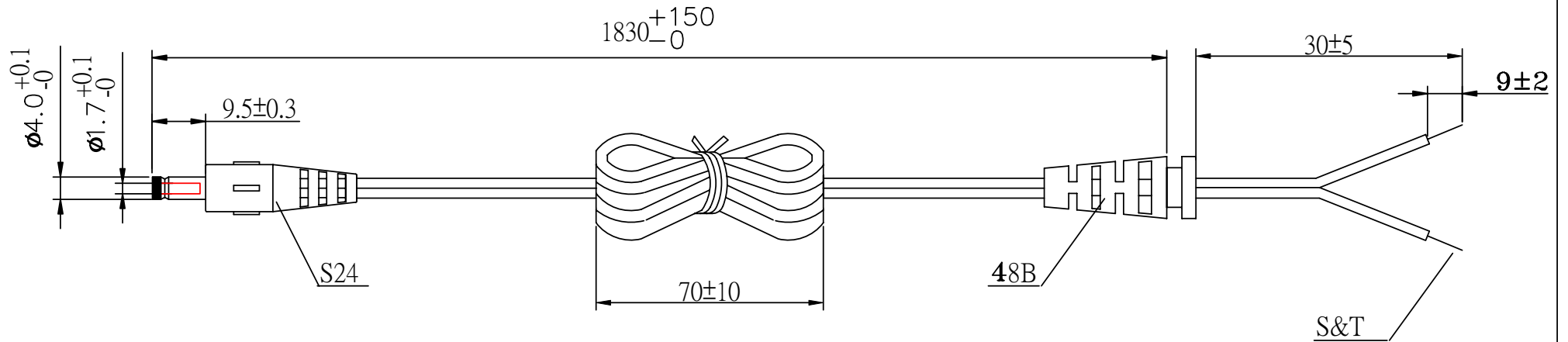

#20AWG X2C UL2468

OD: $\varnothing 1.9 \times 3.8$

HAVE ON WORD WIRE IN OUTER, NO WORD WIRE IN INNER(有字接外，無字接內)

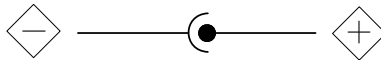

TOLERANCE				

制作參數要求	
搖擺測試 VIBRATION TEST	a. $\pm 60^\circ$ b. 吊重200g WEIGHT 200g c. 40回/分 40 ROUND/MINUTE d. 1000次/最少 OVER 1000 COUNT MIN

DESIGNED	CHECKED	APPROVED	TITLE		DATE
Hump	Zhoujg	Bill	DC CORD		07/01/11
			UNITS	mm	DRAWING No.
			SCALE		SPS0502E2-T
				DRAWING NAME	REVISION
				31-48BS24-04B-00	01