





Revision: 02

Approval Sheet

CUSTOMER: AC48

CUSTOMER MODEL NO.: _____

ENG MODEL NO.: EPAS-101W-09ENG PART NO.: @3A-101WX09-037DESCRIPTION: SWITCHING POWER SUPPLYDATE: 2009/7/20

PREPARED	DESIGNED	CHECKED	APPROVED
	 		

APPROVAL DATE:

CUSTOMER APPROVAL		

1 Product Characteristics:

1.1 General Description

Model EPAS-101W-09 is a universal switching-mode power supply, operating at input voltage 90VAC to 255VAC and output voltage of 9VDC with 1.3A DC load

1.2 Electric Characteristics

1.2.1 Input

No	ITEM	SPECIFICATION
1.	Rated input Voltage	AC100V-240V
	Vibration input Voltage Range	AC90V-255V
2.	Frequency Rated	50-60Hz
	Frequency Vibration	47-63Hz
3.	Input Rated Current	300mA RMS Max
	Inrush Current	15A Max .at 115vac cool start
		30A Max .at 230vac cool start
4.	Leakage current	0.25mA
5.	Efficiency	60% Min.

1.2.2 Output:

No	ITEM	V1
1.	output Voltage	9VDC
2.	output max. current	1.3A
3.	output min. Current	0A
4.	Line regulation	± 1%
5.	Output voltage tolerance	± 5%
6.	Over voltage protection	11.4V to12.6VDC(output shut down)
7.	Short circuit protection	Output shut down and auto restart
8.	Ripple Voltage (L.F.)	150mV (p-p) (100V-240VAC at full load)

1.2.3 HI-POT SPECIFICATION

Input to output : 3000VAC 10mA 1 minute.

1.2.4 Insulation resistance:

Input to output: 500vdc to test the input to output resistance not be less 100M ohm

1.2.5 Safety approved: UL,CUL,PSE**1.2.6 EMI standard : meet EN55022 B****1.2.7 PB-free standard: RoHS Compliant**

1.3 Mechanical Characteristics

1.3.1 AC plug: Direct plug-In UL Type.

1.3.2 DC cord:

(1)Bending test: Life 1000 times 100% guarantee. Swings 120 from

Left to right loading weight 200g , 40 cycle/minute.

(2)Pull test : DC cord and plug ,weight 6kg for 1 minute.

1.3.3 Cord length and output plug: See Reference Att.4

1.3.4 Weight : 112 g

1.3.5 Case Size: (L)60 X (W) 44 X (H) 25mm

1.3.6 Normal operating temperature and humidity

1.3.7 Temperature

Operating: 0°C to 40°C

Storage : -10°C to 70°C

1.3.8 Humidity

Operating : 20% to 80%.

Storage: 10% to 90%

2.Attachment:

- (Att.1) Label**
- (Att.2) Outdrawing**
- (Att.3) Package**
- (Att.3.1) Package flow chart**
- (Att.4) Dc cord drawing**
- (Att.5) Electrical test report**

Att.1

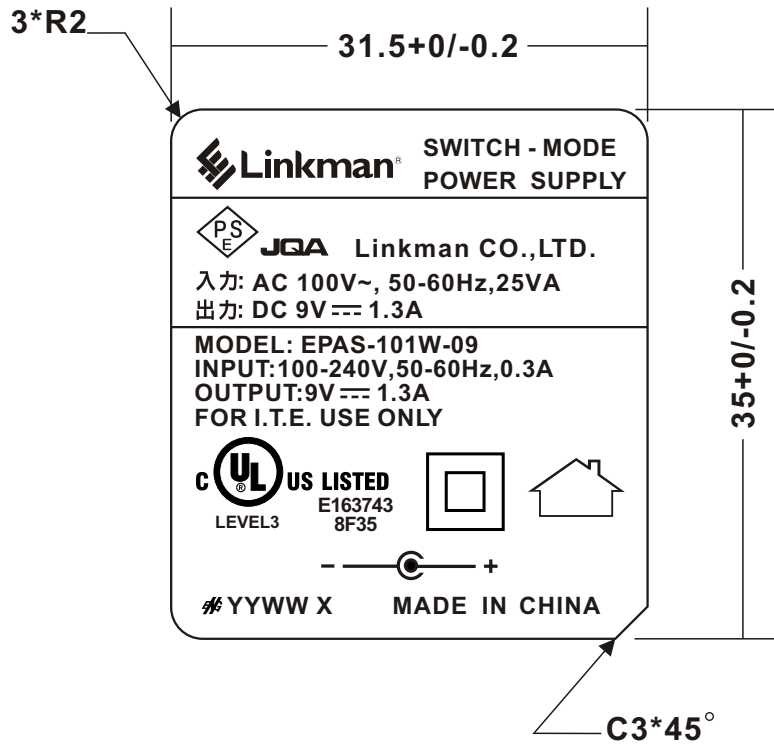

UNIT: mm

YYWW X YY:YEAR WW:WEEK X=S or A(S:FU YONG A:DONG GUAN)

ALUMINUM NAMEPLATE:○ BLACK WORD ON SILVER BASE

○ SILVER WORD ON BLACK BASE

METALIZED POLYESTER:○ BLACK WORD ON SILVER BASE

(SILVER MATTE) ● SILVER WORD ON BLACK BASE

@3A-101WX09-037

TOLERANCE				

DESIGNED	CHECKED	APPROVED		TITLE	DATE
<i>Hamp</i>	<i>Luobq</i>	<i>Bill</i>		UNITS	LABEL
			mm	DRAWING No.	09/07/20
			SCALE	@N20-AC48A0-A03	
			2:1	DRAWING NAME	REVISION
				1002	01

Att.2

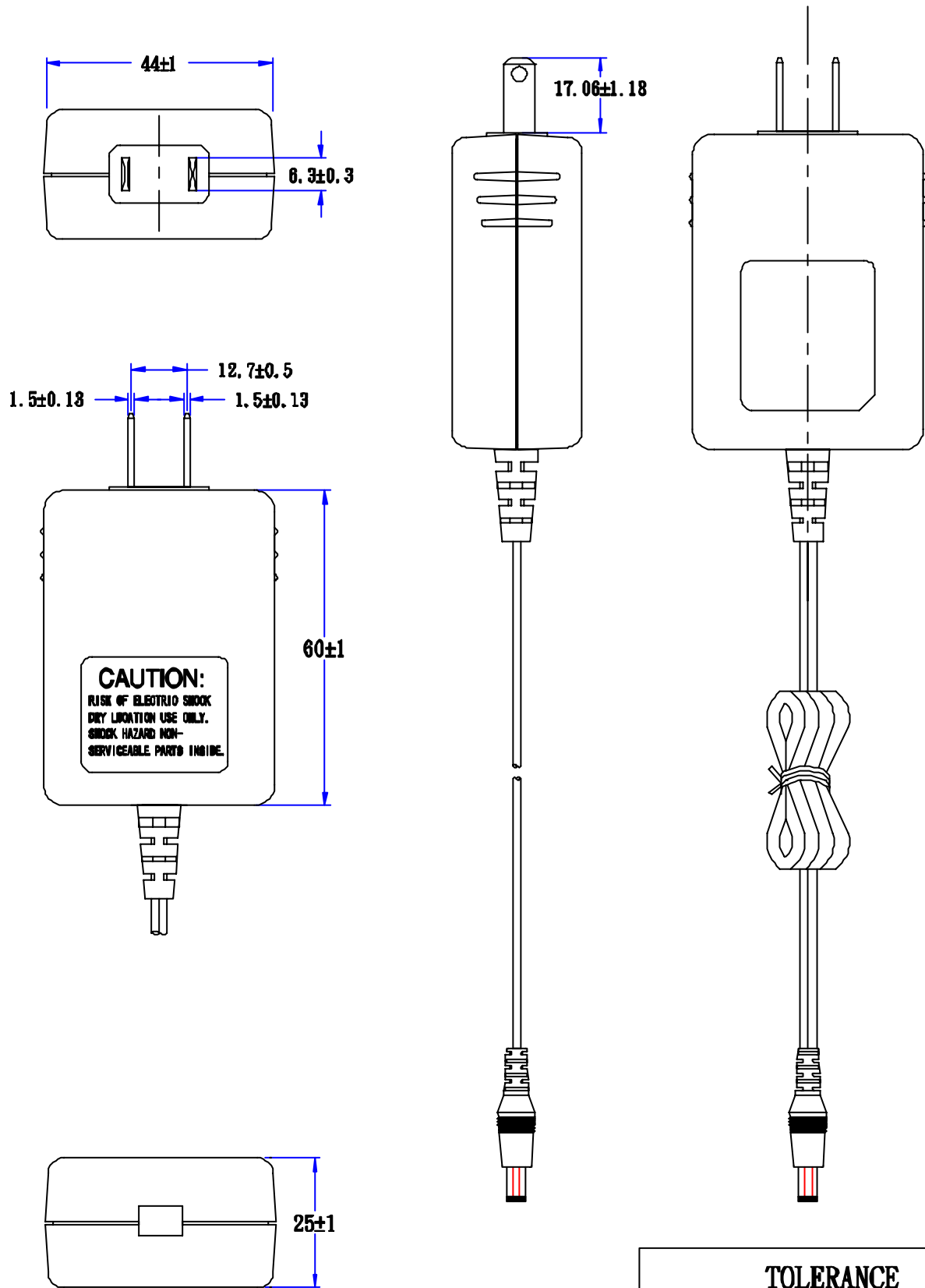

TOLERANCE				

DESIGNED	CHECKED	APPROVED		TITLE	DATE
<i>Hump</i>	<i>Zhoujg</i>	<i>Bill</i>		UNITS	OUTDRAWING
				DRAWING No.	REVISION
				SCALE	
				DRAWING NAME	
				100201	

Att.3

CARTON SIZE:375*368*225mm

Q'TY: 80PCS(20*4)

數量 80PCS(20*4)

N.W: 8.96KGS

G.W: 9.76KGS

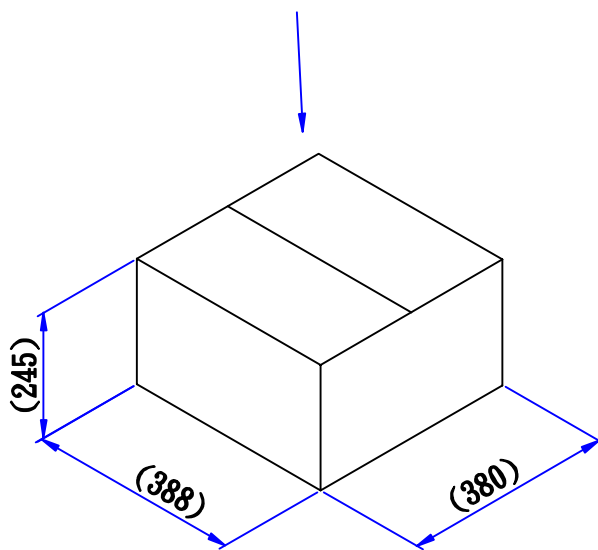
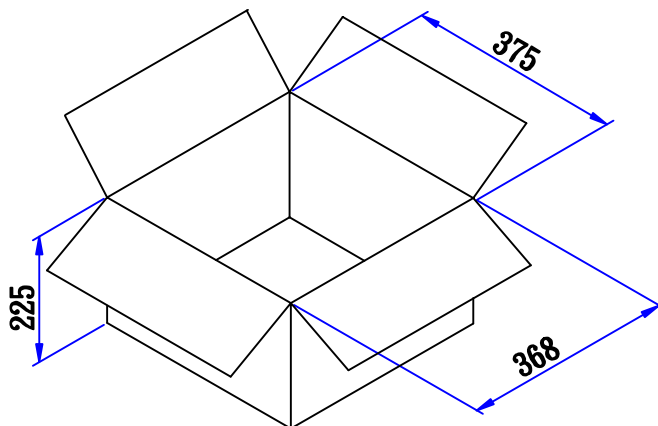

The tolerance of the internal dimensions of the carton is +7/-0

紙箱內度尺寸公差為：+7/-0

TOLERANCE				

DESIGNED	CHECKED	APPROVED	TITLE		DATE
<i>Hump</i>	<i>Zhoujg</i>	<i>Bill</i>	PACKAGE		06/12/16
			UNITS	mm	DRAWING No.
			SCALE		P36-2040-H-50
			DRAWING NAME		REVISION
			36-2040-H-50		01

Att.3.1

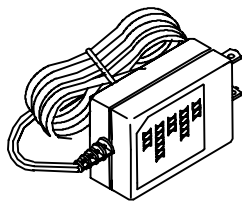

← Product

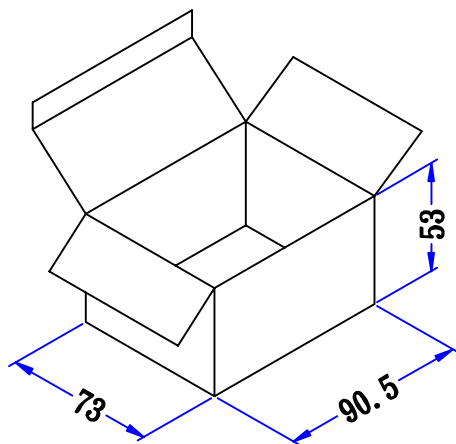

← WHITE BOX: 36#

The tolerance of the external dimensions of the white box is ± 1
 小禮盒外度尺寸公差為 ± 1

TOLERANCE				

DESIGNED	CHECKED	APPROVED		TITLE	DATE
<i>Hump</i>	<i>Zhoujg</i>	<i>Bill</i>		PACKAGE FLOW CHART	06/12/16
			UNITS	DRAWING No.	REVISION
			SCALE	@3A-101WX09-037	
				DRAWING NAME	01
				36#	

Att.4

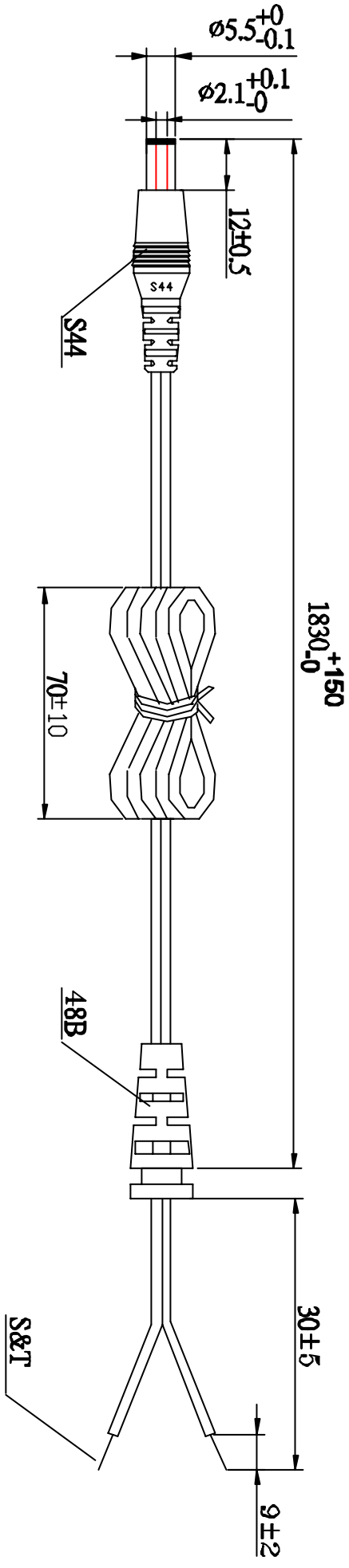

#20A WG X2C UL2468
 OD: Ø1.9X3.8

HAVE ON WORD WIRE IN OUTER, NO WORD WIRE IN INNER



TOLERANCE	

搖擺測試 VIBRATION TEST a. ±60° b. 重量200g WEIGHT 200g c. 40回/分 40 ROUND/MINUTE d. 1000次/最少 OVER 1000 COUNT MIN	DESIGNED	CHECKED	APPROVED	UNITS	mm	TITLE	DATE
	<i>Shangyi</i>	<i>Shangyi</i>	<i>SBW</i>	SCALE		DC CORD	06/12/16
						DRAWING No. @3A-101WX09-037	REVISION 01
						DRAWING NAME 31-48BS44-03B-00	