





Revision: 02

# Approval Sheet

CUSTOMER: AC48

CUSTOMER MODEL NO.: \_\_\_\_\_

MODEL NO.: SPS15D8PCPART NO.: @3A-101WX15-024DESCRIPTION: SWITCHING POWER SUPPLYDATE: 2009/7/20

PREPARED	DESIGNED	CHECKED	APPROVED
	 		

APPROVAL DATE:

CUSTOMER APPROVAL		





## 1 Product Characteristics:

### 1.1 General Description

Model SPS15D8PC is a universal switching-mode power supply, operating at input voltage 90VAC to 255VAC and output voltage of 15VDC with 0.8A DC load

### 1.2 Electric Characteristics

#### 1.2.1 Input

No	ITEM	SPECIFICATION
1.	Rated input Voltage	AC100V-240V
	Vibration input Voltage Range	AC90V-255V
2.	Frequency Rated	50-60Hz
	Frequency Vibration	47-63Hz
3.	Input Rated Current	300mA RMS Max
	Inrush Current	25A Max .at 115vac cool start
		50A Max .at 230vac cool start
4.	Leakage current	0.25mA
5.	Efficiency	65% Min.

**1.2.2 Output:**

No	ITEM	V1
1.	output Voltage	15VDC
2.	output max. current	0.8A
3.	output min. Current	0A
4.	Line regulation	$\pm 1\%$
5.	Output voltage tolerance	$\pm 5\%$
6.	Over voltage protection	The output voltage shall be clamped by internal protection zener
7.	Short circuit protection	Output shut down and auto restart
8.	Ripple Voltage (L.F.)	150mV (p-p) (100V-240VAC at full load)

**1.2.3 HI-POT SPECIFICATION**

Input to output : 3000VAC 10mA 1 minute.

**1.2.4 Insulation resistance:**

Input to output: 500vdc to test the input to output resistance not be less 100M ohm

**1.2.5 Safety approved: PSE,UL,CUL****1.2.6 EMI standard : meet EN55022 B****1.2.7 PB-free standard: RoHS Compliant**

### 1.3 Mechanical Characteristics

1.3.1 AC plug: Direct plug-In UL Type.

1.3.2 DC cord:

(1) Bending test: Life 1000 times 100% guarantee. Swings 120 from

Left to right loading weight 200g , 40 cycle/minute.

(2) Pull test : DC cord and plug ,weight 6kg for 1 minute.

1.3.3 Cord length and output plug: See Reference Att.4

1.3.4 Weight : 112 g

1.3.5 Case Size: (L)60 X (W) 44 X (H) 25mm

1.3.6 Normal operating temperature and humidity

1.3.7 Temperature

Operating: 0°C to 40°C

Storage : -10°C to 70°C

1.3.8 Humidity

Operating : 20% to 80%.

Storage: 10% to 90%

**FILE NO.: EN-RDS-J590    FILE:    SPS15D8PC**

**SHEET:04**

---

**2.Attachment:**

- (Att.1)    Label**
- (Att.2)    Outdrawing**
- (Att.3)    Package**
- (Att.3.1)    Package flow chart**
- (Att.4)    Dc cord drawing**
- (Att.5)    Electrical test report**

Att.1

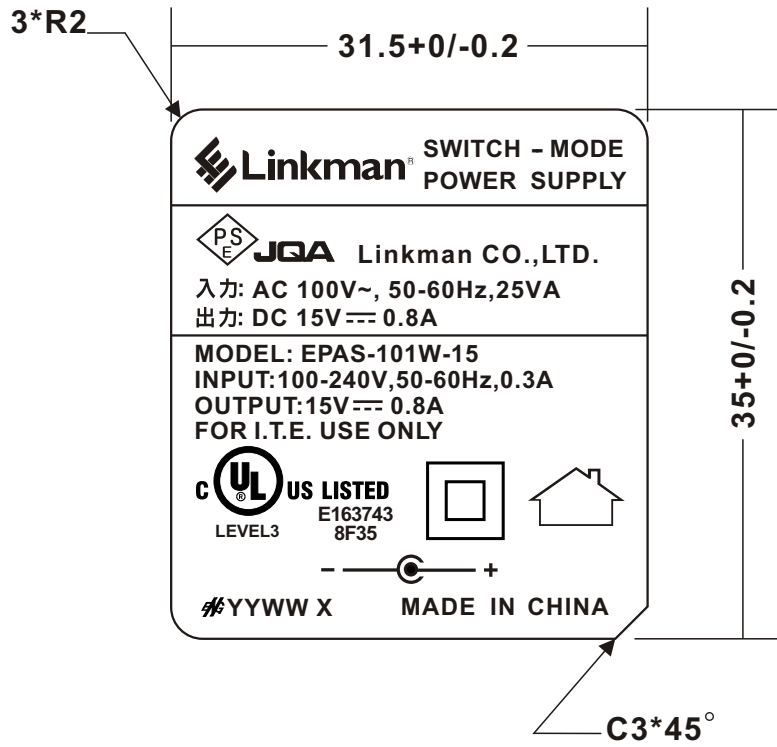

UNIT: mm

YYWW X YY:YEAR WW:WEEK X=S or A(S:FU YONG A:DONG GUAN)

ALUMINUM NAMEPLATE:○ BLACK WORD ON SILVER BASE

○ SILVER WORD ON BLACK BASE

METALIZED POLYESTER:○ BLACK WORD ON SILVER BASE

(SILVER MATTE)

● SILVER WORD ON BLACK BASE

**@3A-101WX15-024**

TOLERANCE				

DESIGNED	CHECKED	APPROVED		TITLE	DATE
<i>Hamp</i>	<i>Luoly</i>	<i>Bill</i>		UNITS	LABEL
			mm	DRAWING No.	
			SCALE	@N20-AC48A0-A05	
			2:1	DRAWING NAME	REVISION
				1002	01



Att.2

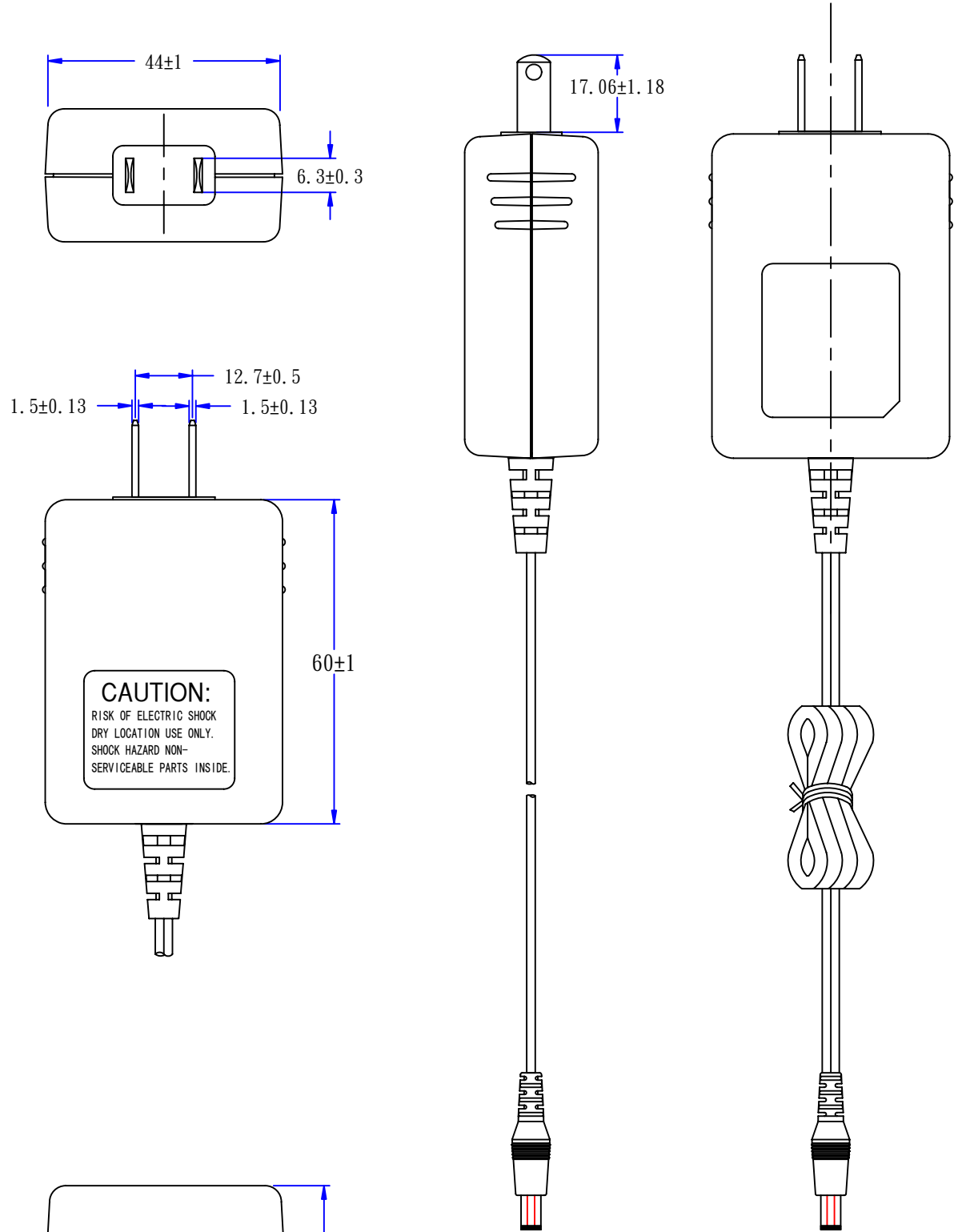

TOLERANCE				

DESIGNED	CHECKED	APPROVED		TITLE	DATE
<i>Hump</i>	<i>Zhoujg</i>	<i>Bill</i>		UNITS	OUTDRAWING
			mm	DRAWING No.	06/12/16
			SCALE	<b>SPS15D8PC</b>	
				DRAWING NAME	REVISION
				<b>100201</b>	<b>01</b>

Att.3

CARTON SIZE:375\*368\*225mm

Q'TY: 80PCS(20\*4)

數量 80PCS(20\*4)

N.W: 8.96KGS

G.W: 9.76KGS

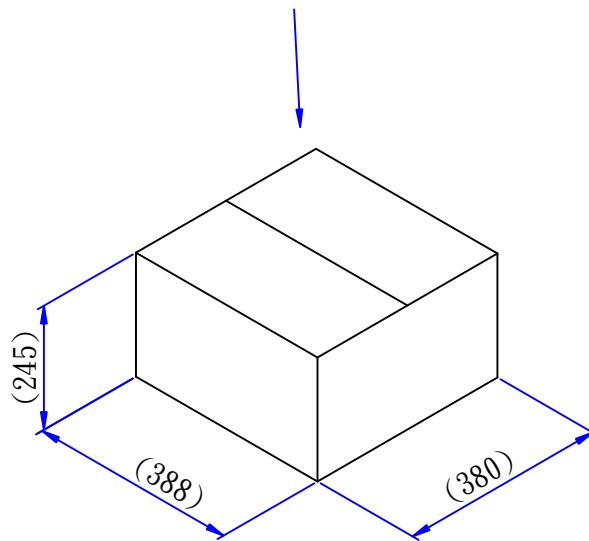
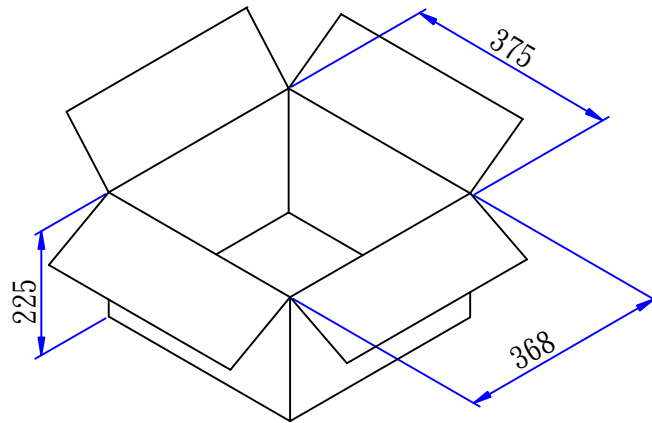

The tolerance of the internal dimensions of the carton is +7/-0

紙箱內度尺寸公差為：+7/-0

TOLERANCE				

DESIGNED	CHECKED	APPROVED		TITLE	PACKAGE	DATE
<i>Hump</i>	<i>Zhoujg</i>	<i>Bill</i>		UNITS	DRAWING No.	06/12/16
			mm	P36-2040-H-50		
			SCALE	DRAWING NAME	REVISION	
				36-2040-H-50	01	

Att.3.1

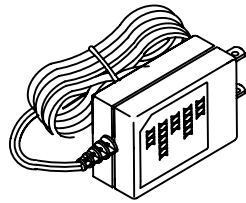

← Product

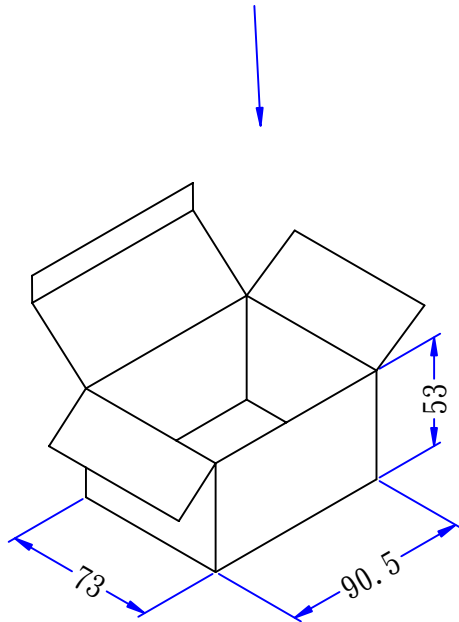

← WHITE BOX:36#

The tolerance of the external dimensions of the white box is  $\pm 1$   
 小禮盒外度尺寸公差為： $\pm 1$

TOLERANCE				

DESIGNED	CHECKED	APPROVED			TITLE	DATE
<i>Hump</i>	<i>Zhoujg</i>	<i>Bill</i>	UNITS	mm	PACKAGE FLOW CHART	
			SCALE		DRAWING No. <b>SPS15D8PC</b>	06/12/16
					DRAWING NAME <b>36#</b>	REVISION <b>01</b>

Att.4

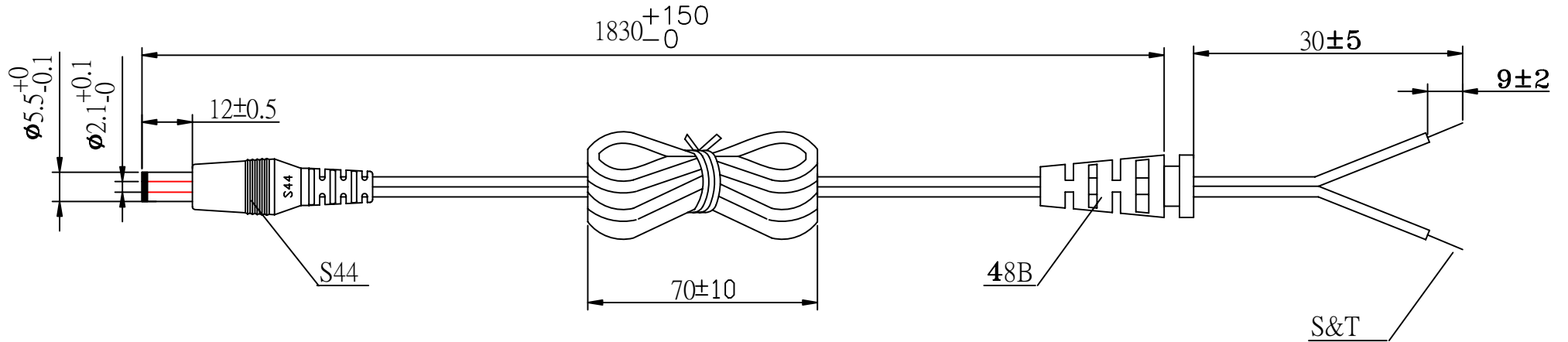

#20AWG X2C UL2468

HAVE ON WORD WIRE IN OUTER, NO WORD WIRE IN INNER

OD:  $\phi 1.9 \times 3.8$

TOLERANCE				

搖擺測試 VIBRATION TEST	a. $\pm 60^\circ$
	b. 吊重200g WEIGHT 200g
	c. 40回/分 40 ROUND/MINUTE
	d. 1000次/最少 OVER 1000 COUNT MIN

DESIGNED	CHECKED	APPROVED	UNITS		TITLE	DATE
<i>Hump</i>	<i>Zhoujg</i>	<i>Bill</i>		mm	<b>DC CORD</b>	06/12/16
			SCALE		DRAWING No. <b>SPS15D8PC</b>	
					DRAWING NAME <b>31-48BS44-03B-00</b>	REVISION <b>01</b>