

TOSHIBA CMOS Digital Integrated Circuit Silicon Monolithic

## TC74HC4051AP,TC74HC4051AF,TC74HC4051AFT TC74HC4052AP,TC74HC4052AF,TC74HC4052AFT TC74HC4053AP,TC74HC4053AF,TC74HC4053AFN,TC74HC4053AFT

### TC74HC4051AP/AF/AFT

8-Channel Analog Multiplexer/Demultiplexer

### TC74HC4052AP/AF/AFT

Dual 4-Channel Analog Multiplexer/Demultiplexer

### TC74HC4053AP/AF/AFN/AFT

Triple 2-Channel Analog Multiplexer/Demultiplexer

The TC74HC4051A/4052A/4053A are high speed CMOS ANALOG MULTIPLEXER/DEMUTIPLEXER fabricated with silicon gate C<sup>2</sup>MOS technology. They achieve the high speed operation similar to equivalent LSTTL while maintaining the CMOS low power dissipation.

The TC74HC4051A has an 8 channel configuration, the TC74HC4052A has a 4 channel × 2 configuration and the TC74HC4053A has a 2 channel × 3 configuration.

The digital signal to the control terminal turns "ON" the corresponding switch of each channel a large amplitude signal ( $V_{CC} - V_{EE}$ ) can then be switched by the small logical amplitude ( $V_{CC} - GND$ ) control signal.

For example, in the case of  $V_{CC} = 5\text{ V}$ ,  $GND = 0\text{ V}$ ,  $V_{EE} = -5\text{ V}$ , signals between  $-5\text{ V}$  and  $+5\text{ V}$  can be switched from the logical circuit with a single power supply of  $5\text{ V}$ . As the ON-resistance of each switch is low, they can be connected to circuits with low input impedance.

All inputs are equipped with protection circuits against static discharge or transient excess voltage.

### Features

- High speed:  $t_{pd} = 15\text{ ns}$  (typ.) at  $V_{CC} = 5\text{ V}$ ,  $V_{EE} = 0\text{ V}$
- Low power dissipation:  $I_{CC} = 4\text{ }\mu\text{A}$  (max) at  $T_a = 25^\circ\text{C}$
- High noise immunity:  $V_{NIH} = V_{NIL} = 28\% V_{CC}$  (min)
- Low ON resistance:  $R_{ON} = 50\text{ }\Omega$  (typ.) at  $V_{CC} - V_{EE} = 9\text{ V}$
- High noise immunity: THD = 0.02% (typ.) at  $V_{CC} - V_{EE} = 9\text{ V}$
- Pin and function compatible with 4051/4052/4053B

Weight	
DIP16-P-300-2.54A	: 1.00 g (typ.)
SOP16-P-300-1.27A	: 0.18 g (typ.)
SOP16-P-300-1.27	: 0.18 g (typ.)
SOL16-P-150-1.27	: 0.13 g (typ.)
TSSOP16-P-0044-0.65A	: 0.06 g (typ.)

Note: xxxFN (JEDEC SOP) is not available in Japan.

TC74HC4051AP, TC74HC4052AP,  
TC74HC4053AP

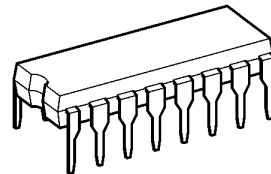

DIP16-P-300-2.54A

TC74HC4051AF, TC74HC4052AF,  
TC74HC4053AF

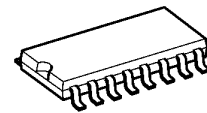

SOP16-P-300-1.27A

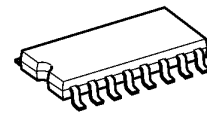

SOP16-P-300-1.27

TC74HC4053AFN

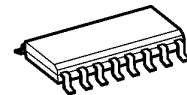

SOL16-P-150-1.27

TC74HC4051AFT, TC74HC4052AFT,  
TC74HC4053AFT

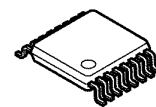

TSSOP16-P-0044-0.65A

## Pin Assignment

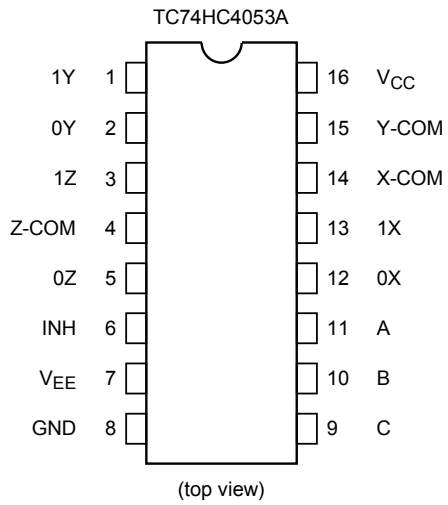
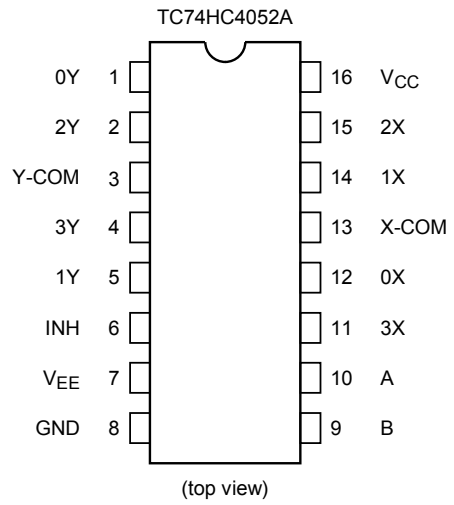
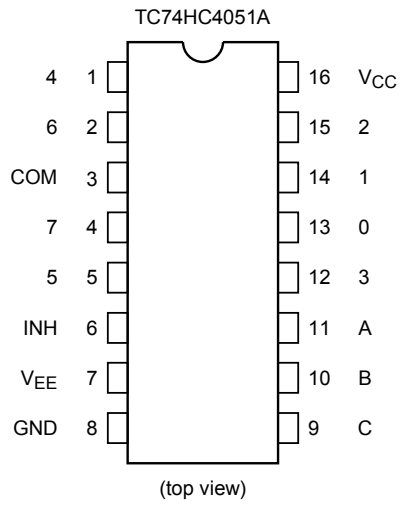

## IEC Logic Symbol

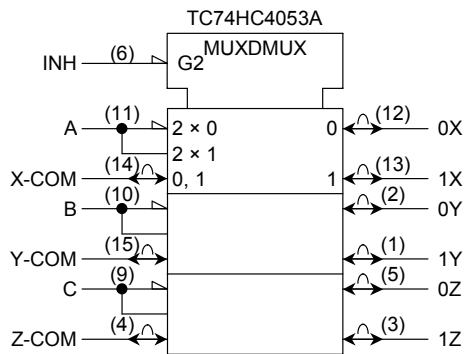
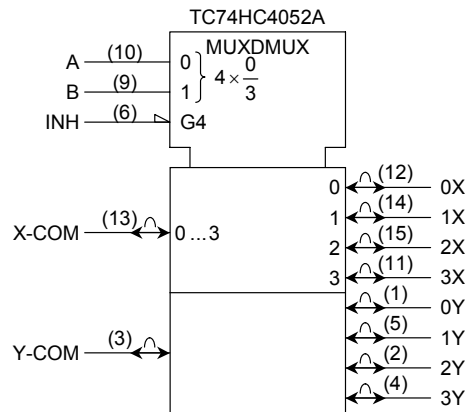
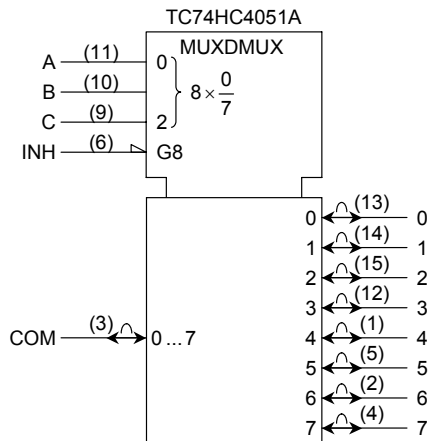

## Truth Table

Control Inputs				"ON" Channel		
Inhibit	C*	B	A	HC4051A	HC4052A	HC4053A
L	L	L	L	0	0X, 0Y	0X, 0Y, 0Z
L	L	L	H	1	1X, 1Y	1X, 0Y, 0Z
L	L	H	L	2	2X, 2Y	0X, 1Y, 0Z
L	L	H	H	3	3X, 3Y	1X, 1Y, 0Z
L	H	L	L	4	—	0X, 0Y, 1Z
L	H	L	H	5	—	1X, 0Y, 1Z
L	H	H	L	6	—	0X, 1Y, 1Z
L	H	H	H	7	—	1X, 1Y, 1Z
H	X	X	X	None	None	None

X: Don't care

\*: Except HC4052A

**System Diagram**

**TC74HC4051A**

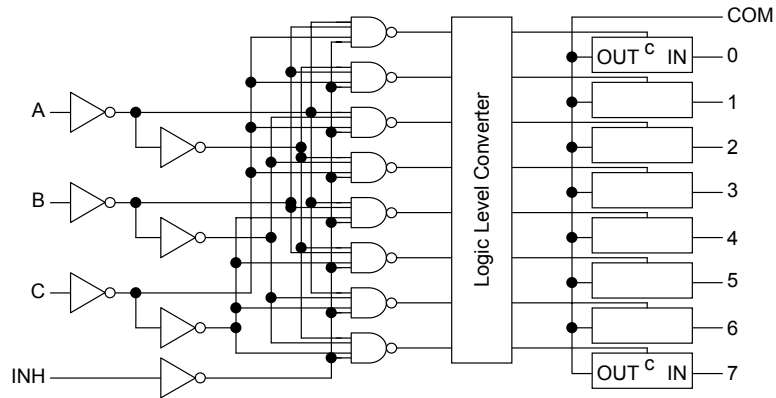

**TC74HC4052A**

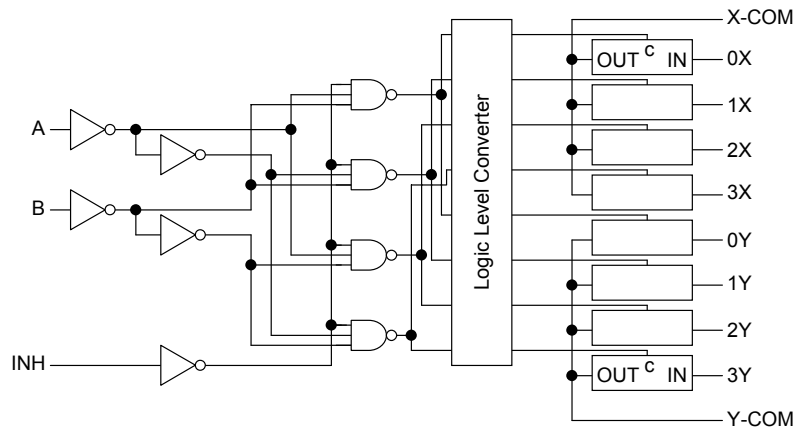

**TC74HC4053A**

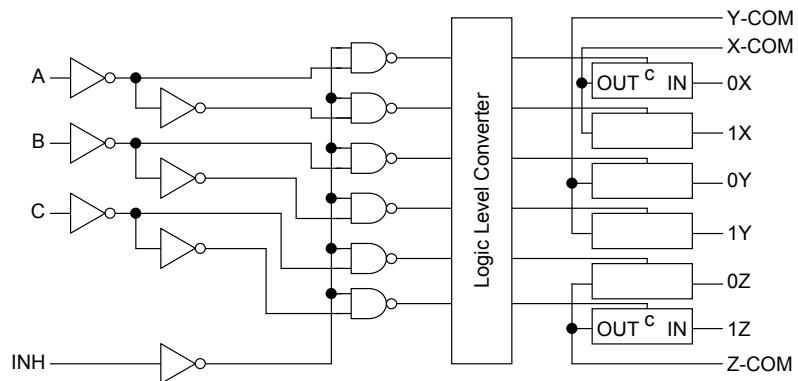

**Absolute Maximum Ratings (Note 1)**

Characteristics	Symbol	Rating	Unit
Supply voltage range	$V_{CC}$	-0.5 to 7	V
Supply voltage range	$V_{CC}-V_{EE}$	-0.5 to 13	V
Control input voltage	$V_{IN}$	-0.5 to $V_{CC} + 0.5$	V
Switch I/O voltage	$V_{I/O}$	$V_{EE} - 0.5$ to $V_{CC} + 0.5$	V
Control input diode current	$I_{ICK}$	$\pm 20$	mA
I/O diode current	$I_{OK}$	$\pm 20$	mA
Switch through current	$I_T$	$\pm 25$	mA
DC $V_{CC}$ or ground current	$I_{CC}$	$\pm 50$	mA
Power dissipation	$P_D$	500 (DIP) (Note 2)/180 (SOP, TSSOP)	mW
Storage temperature	$T_{stg}$	-65 to 150	$^{\circ}C$

Note 1: Exceeding any of the absolute maximum ratings, even briefly, lead to deterioration in IC performance or even destruction.

Note 2: 500 mW in the range of  $T_a = -40$  to  $65^{\circ}C$ . From  $T_a = 65$  to  $85^{\circ}C$  a derating factor of  $-10$  mW/ $^{\circ}C$  should be applied up to 300 mW.

**Recommended Operating Conditions (Note)**

Characteristics	Symbol	Rating	Unit
Supply voltage range	$V_{CC}$	2 to 6	V
Supply voltage range	$V_{EE}$	-6 to 0	V
Supply voltage range	$V_{CC}-V_{EE}$	2 to 12	V
Control input voltage	$V_{IN}$	0 to $V_{CC}$	V
Switch I/O voltage	$V_{I/O}$	$V_{EE}$ to $V_{CC}$	V
Operating temperature	$T_{opr}$	-40 to 85	$^{\circ}C$
Control input rise and fall time	$t_r, t_f$	0 to 1000 ( $V_{CC} = 2.0$ V) 0 to 500 ( $V_{CC} = 4.5$ V) 0 to 400 ( $V_{CC} = 6.0$ V)	ns

Note: The recommended operating conditions are required to ensure the normal operation of the device. Unused inputs must be tied to either VCC or GND.

**Electrical Characteristics**

**DC Characteristics**

Characteristics	Symbol	Test Condition		Ta = 25°C			Ta = -40 to 85°C		Unit	
		V <sub>EE</sub> (V)	V <sub>CC</sub> (V)	Min	Typ.	Max	Min	Max		
High-level control input voltage	V <sub>IHC</sub>	—	2.0 4.5 6.0	1.50 3.15 4.20	— — —	— — —	1.50 3.15 4.20	— — —	V	
Low-level control input voltage	V <sub>ILC</sub>	—	2.0 4.5 6.0	— — —	— — —	0.50 1.35 1.80	— — —	0.50 1.35 1.80	V	
ON resistance	R <sub>ON</sub>	V <sub>IN</sub> = V <sub>ILC</sub> or V <sub>IHC</sub> V <sub>I/O</sub> = V <sub>CC</sub> to V <sub>EE</sub> I <sub>I/O</sub> ≤ 2 mA	GND	4.5	—	85	180	—	225	Ω
			-4.5	4.5	—	55	120	—	150	
		V <sub>IN</sub> = V <sub>ILC</sub> or V <sub>IHC</sub> V <sub>I/O</sub> = V <sub>CC</sub> or V <sub>EE</sub> I <sub>I/O</sub> ≤ 2 mA	GND	2.0	—	150	—	—	—	
			GND	4.5	—	70	150	—	190	
Difference of ON resistance between switches	ΔR <sub>ON</sub>	V <sub>IN</sub> = V <sub>ILC</sub> or V <sub>IHC</sub> V <sub>I/O</sub> = V <sub>CC</sub> to V <sub>EE</sub> I <sub>I/O</sub> ≤ 2 mA	-4.5	4.5	—	5	12	—	15	Ω
			-6.0	6.0	—	5	10	—	12	
			GND	4.5	—	10	30	—	35	
Input/output leakage current (switch off)	I <sub>OFF</sub>	V <sub>OS</sub> = V <sub>CC</sub> or GND V <sub>IS</sub> = GND or V <sub>CC</sub> V <sub>IN</sub> = V <sub>ILC</sub> or V <sub>IHC</sub>	GND	6.0	—	—	±60	—	±600	nA
			-6.0	6.0	—	—	±100	—	±1000	
Switch input leakage current (switch on)	I <sub>Iz</sub>	V <sub>OS</sub> = V <sub>CC</sub> or GND V <sub>IN</sub> = V <sub>ILC</sub> or V <sub>IHC</sub>	GND	6.0	—	—	±60	—	±600	nA
			-6.0	6.0	—	—	±100	—	±1000	
Control input current	I <sub>IN</sub>	V <sub>IN</sub> = V <sub>CC</sub> or GND	GND	6.0	—	—	±0.1	—	±1.0	μA
Quiescent supply current	I <sub>CC</sub>	V <sub>IN</sub> = V <sub>CC</sub> or GND	GND	6.0	—	—	4.0	—	40.0	μA
			-6.0	6.0	—	—	8.0	—	80.0	

## AC Characteristics (C<sub>L</sub> = 50 pF, input: t<sub>r</sub> = t<sub>f</sub> = 6 ns, GND = 0 V)

Characteristics	Symbol	Test Condition		Ta = 25°C			Ta = -40 to 85°C		Unit	
				V <sub>EE</sub> (V)	V <sub>CC</sub> (V)	Min	Typ.	Max		Min
Phase difference between input and output	φ <sub>I/O</sub>	All types	GND	2.0	—	25	60	—	75	ns
			GND	4.5	—	6	12	—	15	
			GND	6.0	—	5	10	—	13	
			-4.5	4.5	—	4	—	—	—	
Output enable time	t <sub>pZL</sub> t <sub>pZH</sub>	4051 (Note 1)	GND	2.0	—	64	225	—	280	ns
			GND	4.5	—	18	45	—	56	
			GND	6.0	—	15	38	—	48	
			-4.5	4.5	—	18	—	—	—	
		4052 (Note 1)	GND	2.0	—	64	225	—	280	
			GND	4.5	—	18	45	—	56	
			GND	6.0	—	15	38	—	48	
			-4.5	4.5	—	18	—	—	—	
		4053 (Note 1)	GND	2.0	—	50	225	—	280	
			GND	4.5	—	14	45	—	56	
			GND	6.0	—	12	38	—	48	
			-4.5	4.5	—	14	—	—	—	
Output disable time	t <sub>pLZ</sub> t <sub>pHZ</sub>	4051 (Note 1)	GND	2.0	—	100	250	—	315	ns
			GND	4.5	—	33	50	—	63	
			GND	6.0	—	28	43	—	54	
			-4.5	4.5	—	29	—	—	—	
		4052 (Note 1)	GND	2.0	—	100	250	—	315	
			GND	4.5	—	33	50	—	63	
			GND	6.0	—	28	43	—	54	
			-4.5	4.5	—	29	—	—	—	
		4053 (Note 1)	GND	2.0	—	95	225	—	280	
			GND	4.5	—	30	45	—	56	
			GND	6.0	—	26	38	—	48	
			-4.5	4.5	—	26	—	—	—	
Control input capacitance	C <sub>IN</sub>	All types	—	—	—	5	10	—	10	pF
COMMON terminal capacitance	C <sub>IS</sub>	4051	—	—	—	36	70	—	70	pF
		4052	-5.0	5.0	—	19	40	—	40	
		4053	—	—	—	11	20	—	20	
SWITCH terminal capacitance	C <sub>OS</sub>	4051	—	—	—	7	15	—	15	pF
		4052	-5.0	5.0	—	7	15	—	15	
		4053	—	—	—	7	15	—	15	
Feedthrough capacitance	C <sub>IOS</sub>	4051	—	—	—	0.95	2	—	2	pF
		4052	-5.0	5.0	—	0.85	2	—	2	
		4053	—	—	—	0.75	2	—	2	
Power dissipation capacitance	C <sub>PD</sub>	4051	—	—	—	70	—	—	—	pF
		4052 (Note 2)	GND	5.0	—	71	—	—	—	
		4053	—	—	—	67	—	—	—	

Note 1: R<sub>L</sub> = 1 kΩ

Note 2: C<sub>PD</sub> is defined as the value of the internal equivalent capacitance of IC which is calculated from the operating current consumption without load.

Average operating current can be obtained by the equation:

$$I_{CC (opr)} = C_{PD} \cdot V_{CC} \cdot f_{IN} + I_{CC}$$

## Analog Switch Characteristics (GND = 0 V, Ta = 25°C) (Note 1)

Characteristics	Symbol	Test Condition		Typ.	Unit						
		V <sub>EE</sub> (V)	V <sub>CC</sub> (V)								
Sine wave distortion (T.H.D)		R <sub>L</sub> = 10 kΩ, C <sub>L</sub> = 50 pF f <sub>IN</sub> = 1 kHz	V <sub>IN</sub> = 4.0 V <sub>p-p</sub>	-2.25	2.25	0.025	%				
			V <sub>IN</sub> = 8.0 V <sub>p-p</sub>	-4.5	4.5	0.020					
			V <sub>IN</sub> = 11.0 V <sub>p-p</sub>	-6.0	6.0	0.018					
Frequency response (switch on)	f <sub>max</sub>	Adjust f <sub>IN</sub> voltage to obtain 0dBm at V <sub>OS</sub> Increase f <sub>IN</sub> frequency until dB meter reads -3dB R <sub>L</sub> = 50 Ω, C <sub>L</sub> = 10 pF f <sub>IN</sub> = 1 MHz, sine wave	All (Note 2)	-2.25	2.25	120	MHz				
			4051 (Note 3)			45					
			4052			70					
			4053	95	-4.5	4.5		All (Note 2)	190		
			4051 (Note 3)	70							
			4052	110							
			4053	150	-6.0	6.0		All (Note 2)	200		
			4051 (Note 3)	85							
			4052	140							
			4053	190							
			Feed through attenuation (switch off)		V <sub>IN</sub> is centered at (V <sub>CC</sub> - V <sub>EE</sub> )/2 Adjust input for 0dBm R <sub>L</sub> = 600 Ω, C <sub>L</sub> = 50 pF f <sub>IN</sub> = 1 MHz, sine wave			-2.25	2.25	-50	dB
								-4.5	4.5	-50	
	-6.0	6.0				-50					
Crosstalk (control input to signal output)		R <sub>L</sub> = 600 Ω, C <sub>L</sub> = 50 pF f <sub>IN</sub> = 1 MHz, square wave (t <sub>r</sub> = t <sub>f</sub> = 6 ns)		-2.25	2.25	60	mV				
				-4.5	4.5	140					
				-6.0	6.0	200					
Crosstalk (between any switches)		Adjust V <sub>IN</sub> to obtain 0dBm at input R <sub>L</sub> = 600 Ω, C <sub>L</sub> = 50 pF f <sub>IN</sub> = 1 MHz, sine wave		-2.25	2.25	-50	dB				
				-4.5	4.5	-50					
				-6.0	6.0	-50					

Note 1: These characteristics are determined by design of devices.

Note 2: Input COMMON terminal, and measured at SWITCH terminal.

Note 3: Input SWITCH terminal, and measured at COMMON terminal.



## Switching Characteristics Test Circuits

### 1. $t_{pLZ}$ , $t_{pHZ}$ , $t_{pZL}$ , $t_{pZH}$

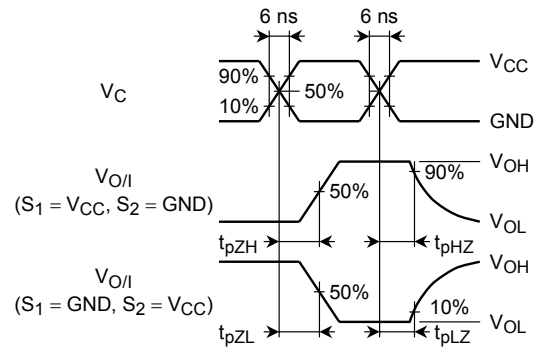
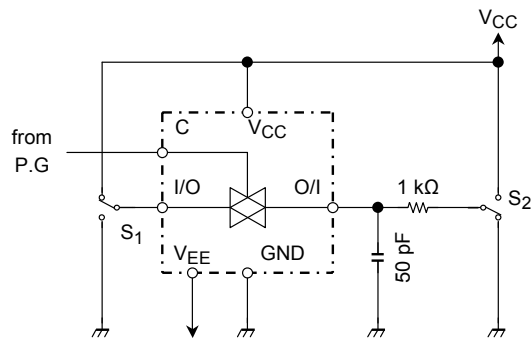

### 2. Cross Talk (control input-switch output) $f_{IN} = 1$ MHz duty = 50% $t_r = t_f = 6$ ns

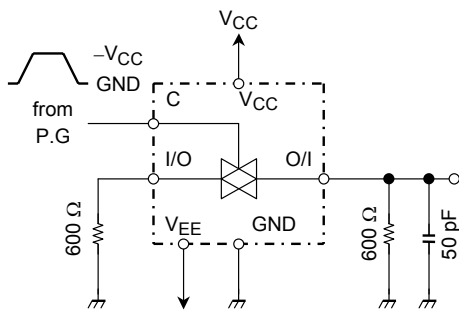

### 3. Feedthrough Attenuation

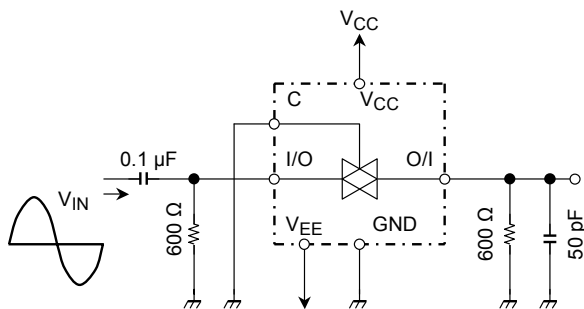

**4. C<sub>IOS</sub>, C<sub>IS</sub>, C<sub>OS</sub>**

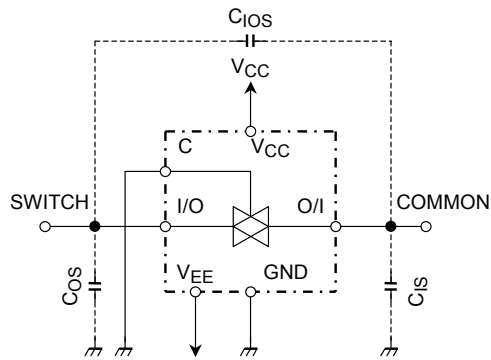

**5. Cross Talk (between any two switches)**

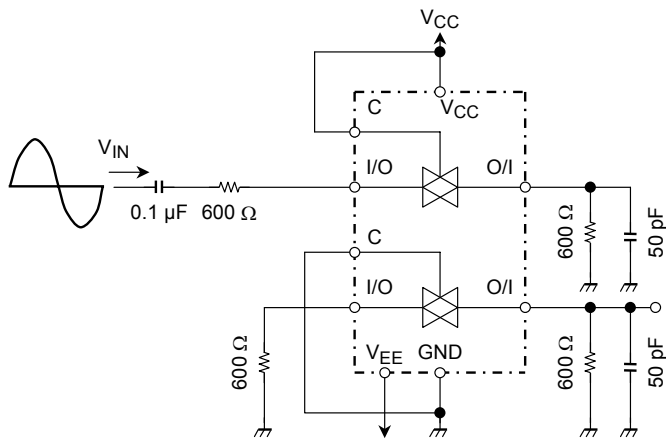

**6. Frequency Response (switch on)**

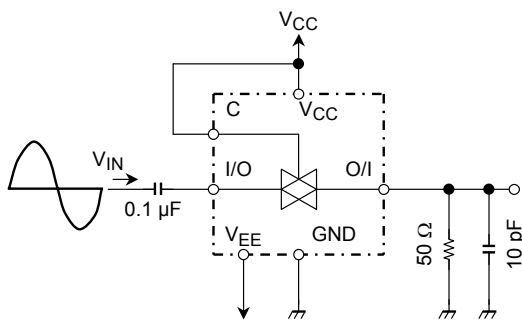

**Package Dimensions**

DIP16-P-300-2.54A

Unit : mm

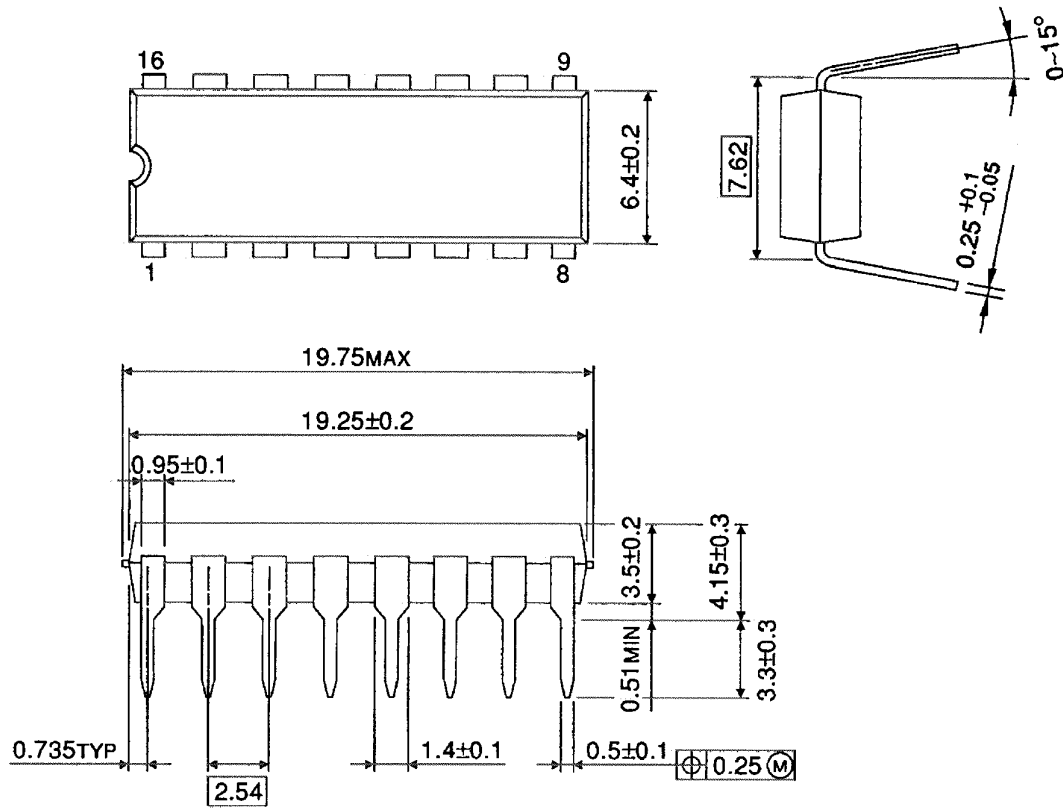

Weight: 1.00 g (typ.)

**Package Dimensions**

SOP16-P-300-1.27A

Unit: mm

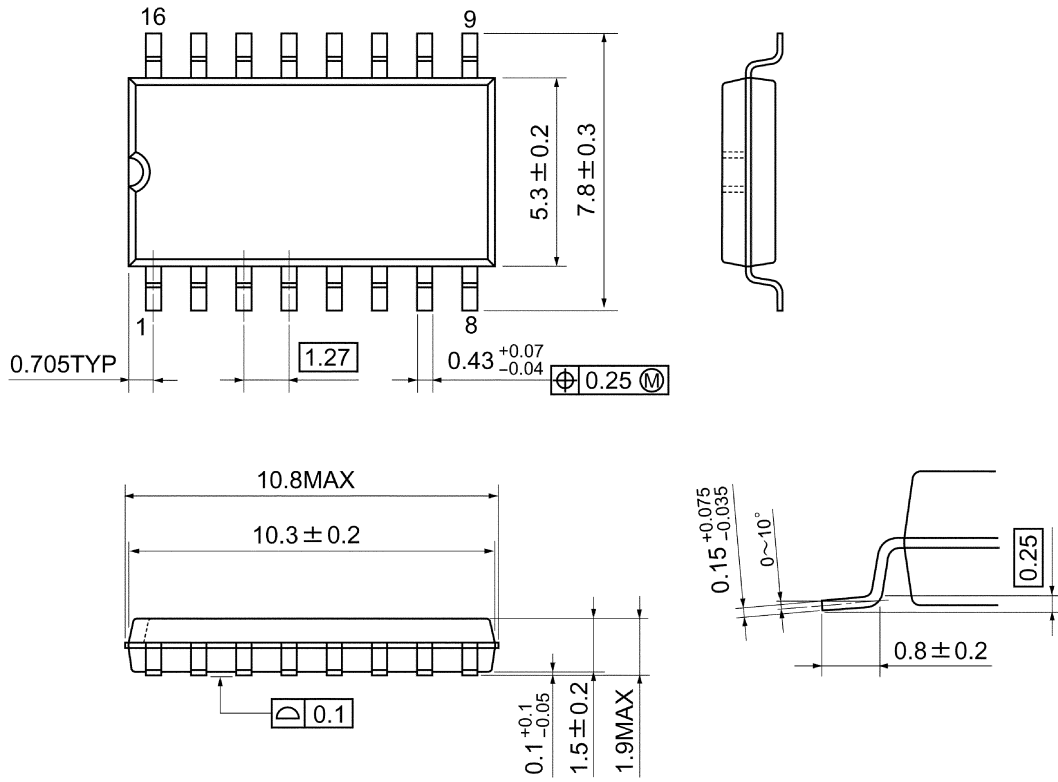

Weight: 0.18 g (typ.)

**Package Dimensions**

SOP16-P-300-1.27

Unit : mm

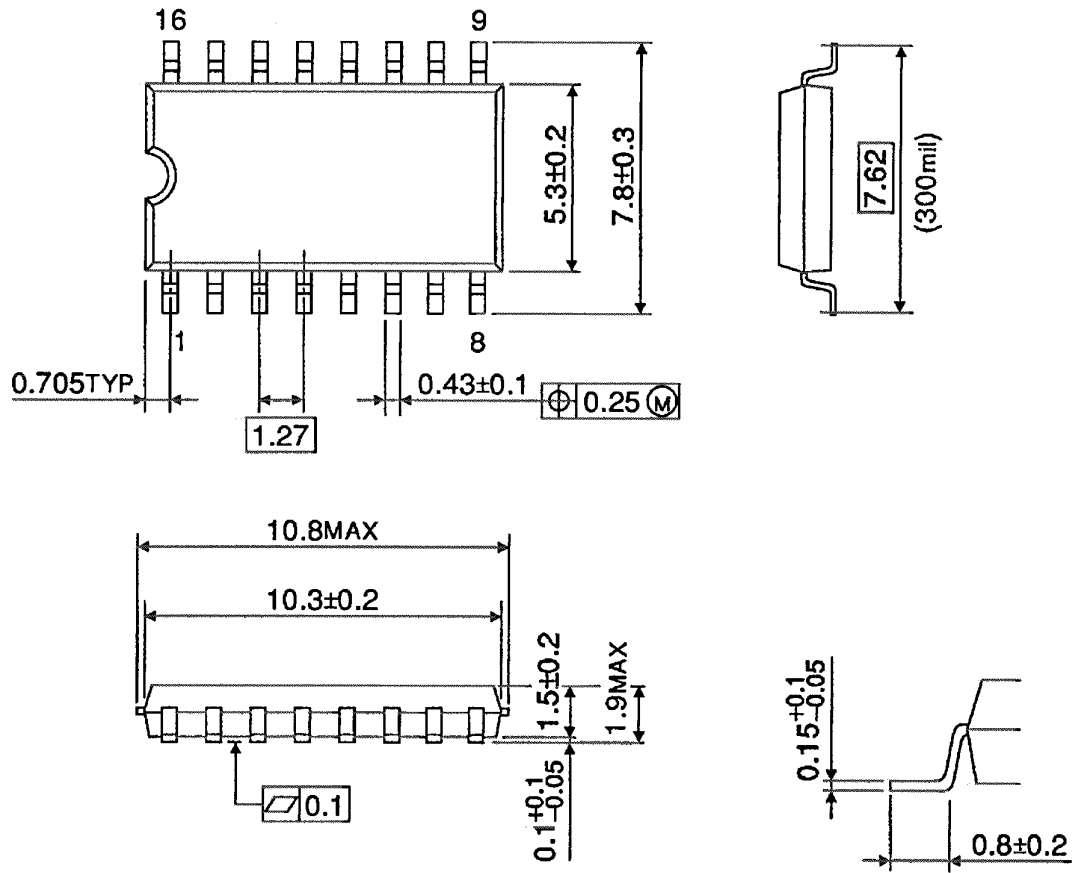

Weight: 0.18 g (typ.)

**Package Dimensions (Note)**

SOL16-P-150-1.27

Unit : mm

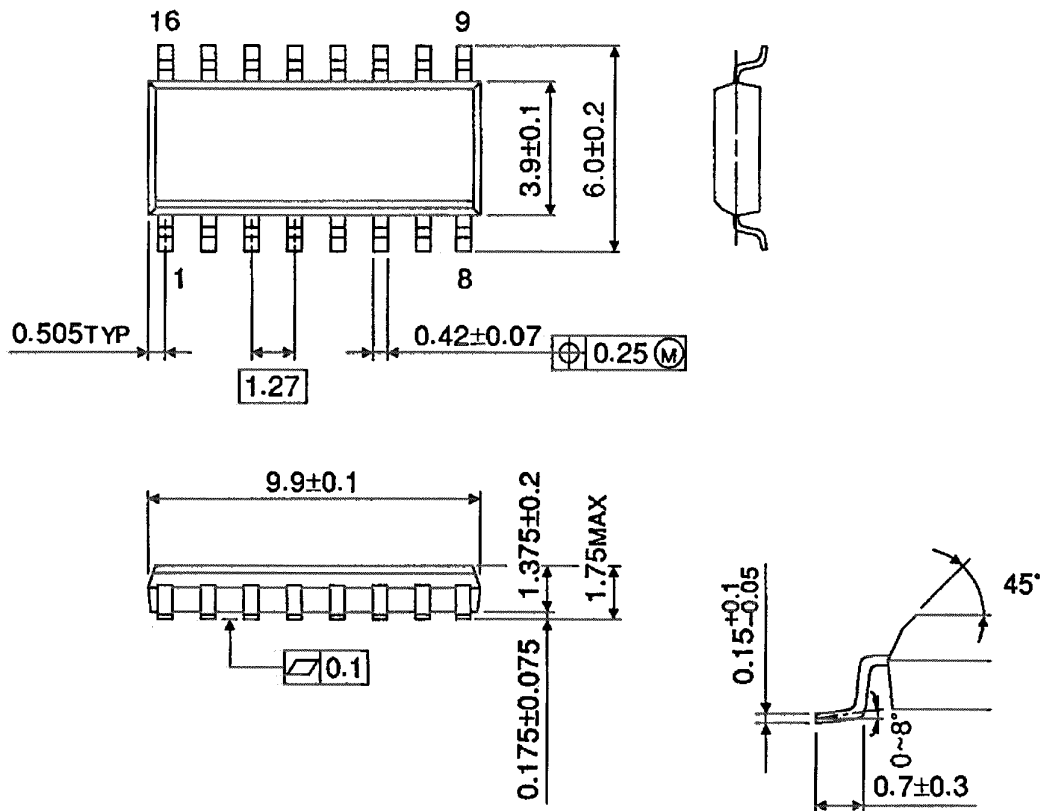

Note: This package is not available in Japan.

Weight: 0.13 g (typ.)

**Package Dimensions**

TSSOP16-P-0044-0.65A

Unit: mm

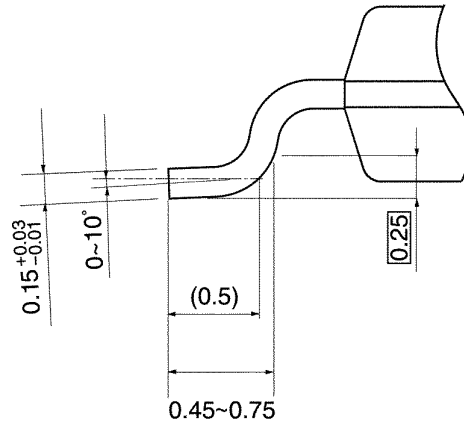
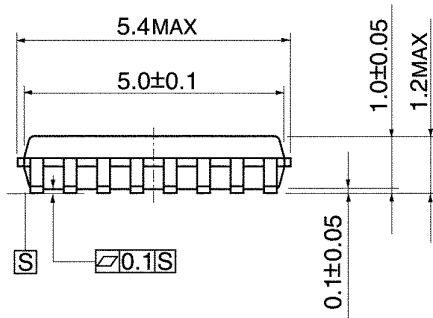
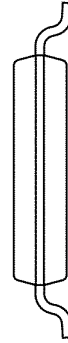
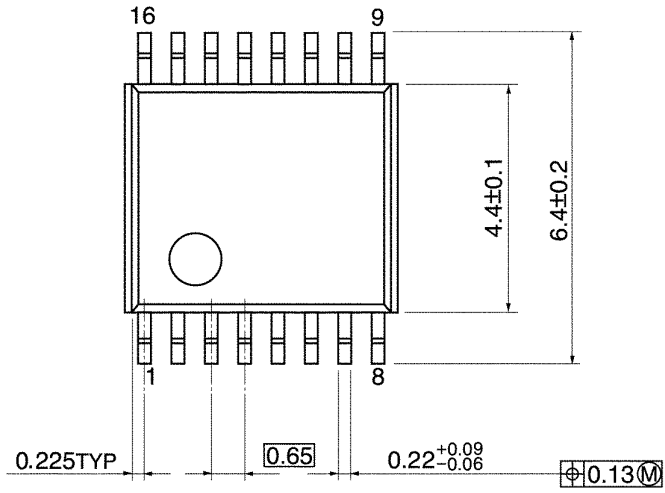

Weight: 0.06 g (typ.)

**Note: Lead (Pb)-Free Packages****DIP16-P-300-2.54A SOP16-P-300-1.27A SOL16-P-150-1.27 TSSOP16-P-0044-0.65A****RESTRICTIONS ON PRODUCT USE**

060116EBA

- The information contained herein is subject to change without notice. 021023\_D
- TOSHIBA is continually working to improve the quality and reliability of its products. Nevertheless, semiconductor devices in general can malfunction or fail due to their inherent electrical sensitivity and vulnerability to physical stress. It is the responsibility of the buyer, when utilizing TOSHIBA products, to comply with the standards of safety in making a safe design for the entire system, and to avoid situations in which a malfunction or failure of such TOSHIBA products could cause loss of human life, bodily injury or damage to property.  
In developing your designs, please ensure that TOSHIBA products are used within specified operating ranges as set forth in the most recent TOSHIBA products specifications. Also, please keep in mind the precautions and conditions set forth in the "Handling Guide for Semiconductor Devices," or "TOSHIBA Semiconductor Reliability Handbook" etc. 021023\_A
- The TOSHIBA products listed in this document are intended for usage in general electronics applications (computer, personal equipment, office equipment, measuring equipment, industrial robotics, domestic appliances, etc.). These TOSHIBA products are neither intended nor warranted for usage in equipment that requires extraordinarily high quality and/or reliability or a malfunction or failure of which may cause loss of human life or bodily injury ("Unintended Usage"). Unintended Usage include atomic energy control instruments, airplane or spaceship instruments, transportation instruments, traffic signal instruments, combustion control instruments, medical instruments, all types of safety devices, etc. Unintended Usage of TOSHIBA products listed in this document shall be made at the customer's own risk. 021023\_B
- The products described in this document shall not be used or embedded to any downstream products of which manufacture, use and/or sale are prohibited under any applicable laws and regulations. 060106\_Q
- The information contained herein is presented only as a guide for the applications of our products. No responsibility is assumed by TOSHIBA for any infringements of patents or other rights of the third parties which may result from its use. No license is granted by implication or otherwise under any patent or patent rights of TOSHIBA or others. 021023\_C
- The products described in this document are subject to the foreign exchange and foreign trade laws. 021023\_E