

TOSHIBA CMOS DIGITAL INTEGRATED CIRCUIT SILICON MONOLITHIC

TC7W53F, TC7W53FU, TC7W53FK

2-CHANNEL MULTIPLEXER / DEMULTIPLEXER

The TC7W53 is a high speed CMOS ANALOG MULTIPLEXER/DEMULTIPLEXER fabricated with silicon gate CMOS technology. They achieve the high speed operation similar to equivalent LSTTL while maintaining the CMOS low power dissipation. The TC7W53 has a 2 channel configuration. The digital signal to the control terminal turns "ON" the corresponding switch of each channel a large amplitude signal ($V_{CC}-V_{EE}$) can then be switched by the small logical amplitude ($V_{CC}-GND$) control signal. For example, in the case of $V_{CC}=5V$, $GND=0V$, $V_{EE}=5V$, signals between $-5V$ and $+5V$ can be switched from the logical circuit with a single power supply of 5V. As the ON-resistance of each switch is low, they can be connected to circuit with low input impedance. All inputs are equipped with protection circuits against static discharge or transient excess voltage.

FEATURES

- High Speed $t_{pd} = 15ns$ (Typ.)
at $V_{CC} = 5V$, $V_{EE} = 0V$
- Low Power Dissipation $I_{CC} = 4\mu A$ (Max.) at $T_a = 25^\circ C$
- High Noise Immunity $V_{NIH} = V_{NIL} = 28\% V_{CC}$ (Min.)
- Low ON Resistance $R_{ON} = 50\Omega$ (Typ.)
at $V_{CC}-V_{EE} = 9V$
- High Degree of Linearity $THD = 0.02$ (Typ.)
at $V_{CC}-V_{EE} = 9V$
- Pin and Function Compatible with TC4W53

MARKING

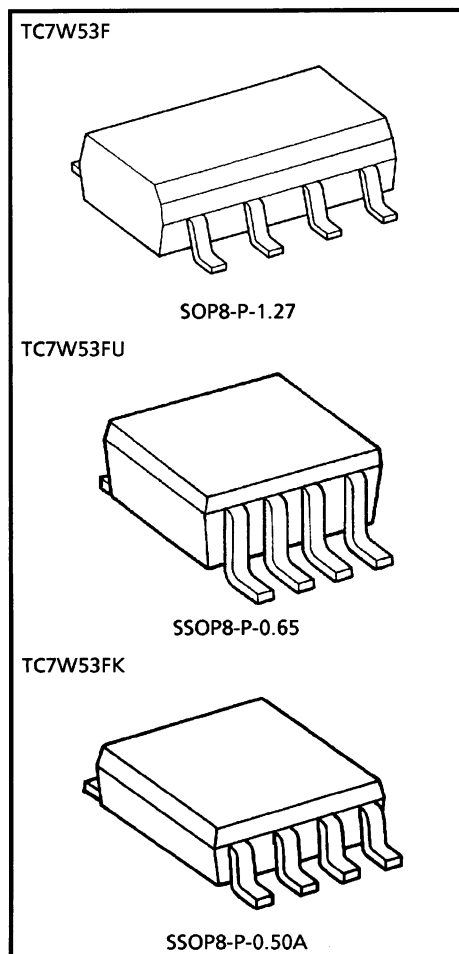
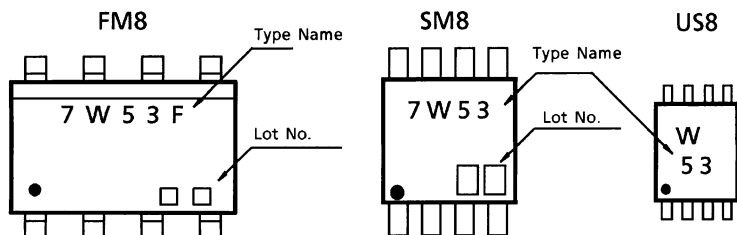

Weight	
SOP8-P-1.27	: 0.05g (Typ.)
SSOP8-P-0.65	: 0.02g (Typ.)
SSOP8-P-0.50A	: 0.01g (Typ.)

MAXIMUM RATINGS (Ta = 25°C)

CHARACTERISTIC	SYMBOL	RATING	UNIT
Supply Voltage Range	V _{CC}	-0.5~7	V
	V _{CC} ~V _{EE}	-0.5~13	
Control Input Voltage	V _{IN}	-0.5~V _{CC} +0.5	V
Switch I/O Voltage	V _{I/O}	V _{EE} -0.5~V _{CC} +0.5	V
Control Input Diode Current	I _{CK}	±20	mA
I/O Diode Current	I _{IOK}	±20	mA
Switch Through Current	I _T	±25	mA
DC V _{CC} /GND Current	I _{CC}	±25	mA
Power Dissipation	P _D	300 (FM8, SM8)	mW
		200 (US8)	
Storage Temperature	T _{stg}	-65~150	°C
Lead Temperature (10 s)	T _L	260	°C

TRUTH TABLE

CONTROL INPUT		ON CHANNEL
INH	A	
L	L	ch 0
L	H	ch 1
H	x	NONE

x : Don't care

LOGIC SYMBOL

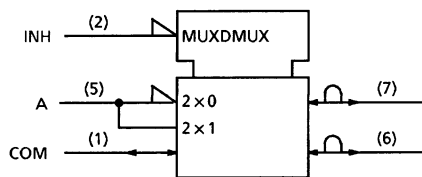

PIN ASSIGNMENT (TOP VIEW)

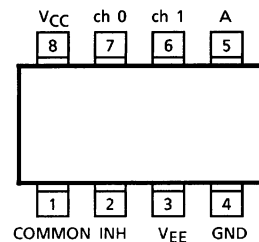

LOGIC DIAGRAM

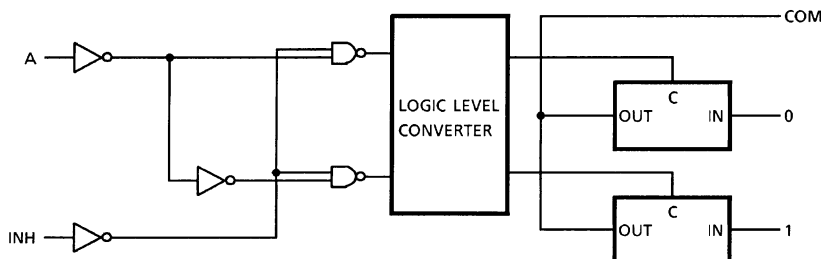

RECOMMENDED OPERATING CONDITIONS

CHARACTERISTIC	SYMBOL	RATING	UNIT
Supply Voltage	V _{CC}	2~6	V
	V _{EE}	-6~0	V
	V _{CC} ~V _{EE}	2~12	V
Control Input Voltage	V _{IN}	0~V _{CC}	V
Switch I/O Voltage	V _{I/O}	0~V _{CC}	V
Operating Temperature	T _{opr}	-40~85	°C
Input Rise and Fall Time	t _r , t _f	0~1000 (V _{CC} = 2.0V)	ns
		0~500 (V _{CC} = 4.5V)	
		0~400 (V _{CC} = 6.0V)	

DC ELECTRICAL CHARACTERISTICS

CHARACTERISTIC	SYMBOL		V _{EE} (V)	V _{CC} (V)	Ta = 25°C			Ta = -40~85°C		UNIT
					MIN.	TYP.	MAX.	MIN.	MAX.	
High-Level Control Input Voltage	V _{IHC}			2.0	1.5	—	—	1.5	—	V
				4.5	3.15	—	—	3.15	—	
				6.0	4.2	—	—	4.2	—	
Low-Level Control Input Voltage	V _{ILC}			2.0	—	—	0.5	—	0.5	V
				4.5	—	—	1.35	—	1.35	
				6.0	—	—	1.8	—	1.8	
ON Resistance	R _{ON}	V _{IN} = V _{IHC} V _{I/O} = V _{CC} to GND V _{I/O} ≤ 2mA	GND	4.5	—	85	180	—	225	Ω
			-4.5	4.5	—	55	120	—	150	
			-6.0	6.0	—	50	100	—	125	
		V _{IN} = V _{IHC} V _{I/O} = V _{CC} or GND V _{I/O} ≤ 2mA	GND	2.0	—	150	—	—	—	
			GND	4.5	—	70	150	—	190	
			-4.5	4.5	—	50	100	—	125	
Difference of ON Resistance Between Switches	ΔR _{ON}	V _{IN} = V _{IHC} V _{I/O} = V _{CC} to GND V _{I/O} ≤ 2mA	GND	4.5	—	10	30	—	35	Ω
			-4.5	4.5	—	5	12	—	15	
			-6.0	6.0	—	5	10	—	12	
Input/Output Leakage Current (SWITCH OFF)	I _{OFF}	V _{OS} = GND V _{IS} = GND to V _{CC} V _{IN} = V _{ILC} or V _{IHC}	GND	6.0	—	—	±60	—	±600	nA
			-6.0	6.0	—	—	±100	—	±1000	
Switch Input Leakage Current (SWITCH ON OUTPUT OPEN)	I _{IZ}	V _{OS} = V _{CC} or GND V _{IN} = V _{ILC} or V _{IHC}	GND	6.0	—	—	±60	—	±600	nA
			-6.0	6.0	—	—	±100	—	±1000	
Control Input Current	I _{IN}	V _{IN} = V _{CC} or GND	GND	6.0	—	—	±0.1	—	±1.0	μA
Quiescent Supply Current	I _{CC}	V _{IN} = V _{CC} or GND	GND	6.0	—	—	4	—	40	μA
			-6.0	6.0	—	—	8	—	80	

AC ELECTRICAL CHARACTERISTICS ($C_L = 50\text{pF}$, Input $t_r = t_f = 6\text{ns}$, GND = 0V)

CHARACTERISTIC		TEST CONDITION	V _{EE} (V)	V _{CC} (V)	Ta = 25°C			Ta = -40~85°C		UNIT
					MIN.	TYP.	MAX.	MIN.	MAX.	
Phase Difference Between Input and Output	ϕ I/O		GND	2.0	—	25	60	—	75	ns
			GND	4.5	—	6	12	—	15	
			GND	6.0	—	5	10	—	13	
			-4.5	4.5	—	4	—	—	—	
Output Enable Time	t_{pZL} t_{pZH}	$R_L = 1\text{k}\Omega$	GND	2.0	—	50	225	—	280	ns
			GND	4.5	—	14	45	—	56	
			GND	6.0	—	12	38	—	48	
			-4.5	4.5	—	14	—	—	—	
Output Disable Time	t_{pLZ} t_{pHZ}	$R_L = 1\text{k}\Omega$	GND	2.0	—	95	225	—	280	ns
			GND	4.5	—	30	45	—	56	
			GND	6.0	—	26	38	—	48	
			-4.5	4.5	—	26	—	—	—	
Control Input Capacitance	C_{IN}		—	—	—	5	10	—	10	pF
Common Terminal Capacitance	C_{IS}		-5.0	5.0	—	11	20	—	20	pF
Switch Terminal Capacitance	C_{OS}		-5.0	5.0	—	7	15	—	15	pF
Feed Through Capacitance	C_{IOS}		-5.0	5.0	—	0.75	2	—	2	pF
Power Dissipation Capacitance	C_{pD}	(Note 1)	GND	5.0	—	67	—	—	—	pF

(Note 1) : C_{pD} is defined as the value of the internal equivalent capacitance which is calculated from the operating current consumption without load.

Average operating current can be obtained by the equation :

$$I_{CC}(\text{opr}) = C_{pD} \cdot V_{CC} \cdot f_{IN} + I_{CC} / 2$$

ANALOG SWITCH CHARACTERISTICS (GND = 0V, Ta = 25°C)

CHARACTERISTIC		TEST CONDITION	V _{EE}	V _{CC}	TYP.	UNIT	
			(V)	(V)			
Sine Wave Distortion (T.H.D)		R _L = 10kΩ, C _L = 50pF f _{IN} = 1kHz	V _{IN} = 4.0V _{p-p}	-2.25	2.25	0.025	%
			V _{IN} = 8.0V _{p-p}	-4.5	4.5	0.02	
			V _{IN} = 1.1V _{p-p}	-6.0	6.0	0.018	
Frequency Response (Switch ON)	f _{MAX}	Adjust f _{IN} voltage to obtain 0dBm at V _{OS} Increase f _{IN} until dB Meter reads -3dB R _L = 50Ω, C _L = 10pF f _{IN} = 1MHz, Sine Wave	*1	-2.25	2.25	120	MHz
			*2			95	
			*1	-4.5	4.5	190	
			*2			150	
			*1	-6.0	6.0	200	
			*2			190	
Feedthrough Attenuation (Switch OFF)		Vin is centered at (V _{CC} -V _{EE})/2 Adjust input for 0dBm R _L = 600Ω, C _L = 50pF f _{IN} = 1MHz, Sine Wave	-2.25	2.25	-50	dB	
			-4.5	4.5	-50		
			-6.0	6.0	-50		
Crosstalk (Control Input to Signal Output)		R _L = 600Ω, C _L = 50pF f _{IN} = 1MHz, Square Wave (t _r = t _f = 6ns)	-2.25	2.25	60	mV	
			-4.5	4.5	140		
			-6.0	6.0	200		
Crosstalk (Between any switches)		Adjust V _{IN} to obtain 0dBm at Input R _L = 600Ω, C _L = 50pF f _{IN} = 1MHz, Sine Wave	-2.25	2.25	-50	dB	
			-4.5	4.5	-50		
			-6.0	6.0	-50		

*1 : Input COMMON Terminal, and measured at SWITCH Terminal.

*2 : Input SWITCH Terminal, and measured at COMMON Terminal.

(Note): These characteristics are determined by design of device.

SWITCHING CHARACTERISTICS TEST CIRCUITS

1. t_{pLZ} , t_{pHZ} , t_{pZL} , t_{pZH}

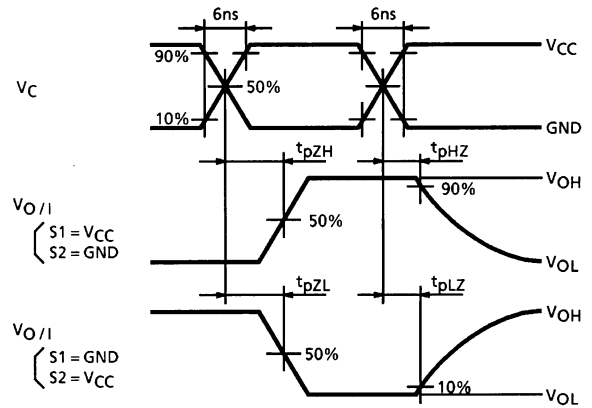
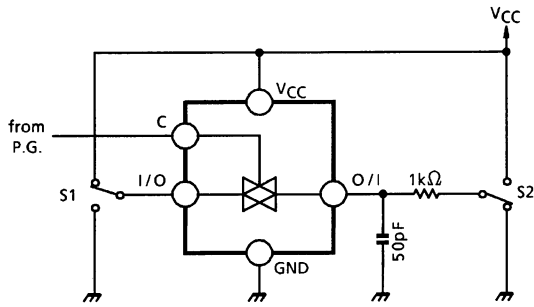

2. CROSS TALK (CONTROL INPUT-SWITCH OUTPUT)

$f_{in} = 1\text{MHz}$, duty = 50%, $t_r = t_f = 6\text{ns}$

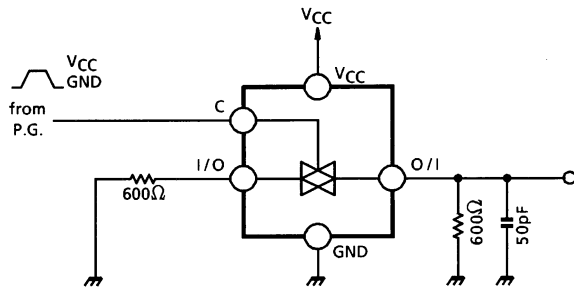

3. FEEDTHROUGH ATTENUATION

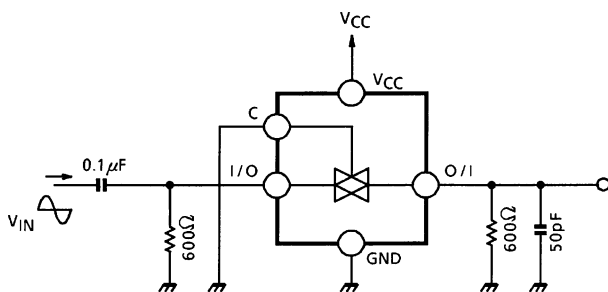

4. Clos, $C_{I/O}$

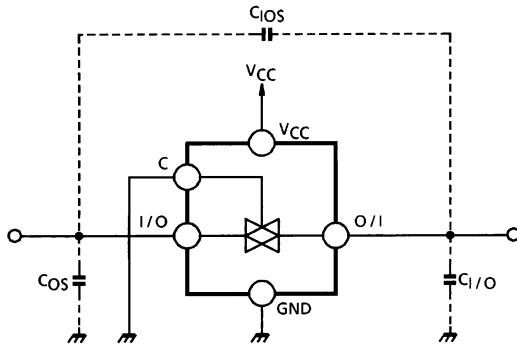

5. CROSS TALK (BETWEEN ANY TWO SWITCHES)

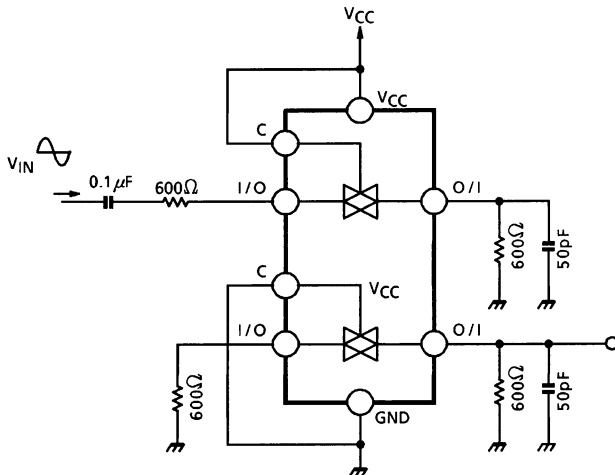

6. FREQUENCY RESPONSE (SWITCH ON)

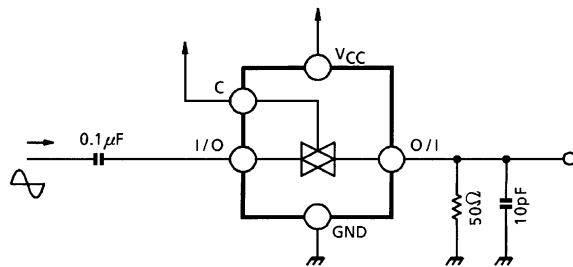

PACKAGE DIMENSIONS
SOP8-P-1.27

Unit : mm

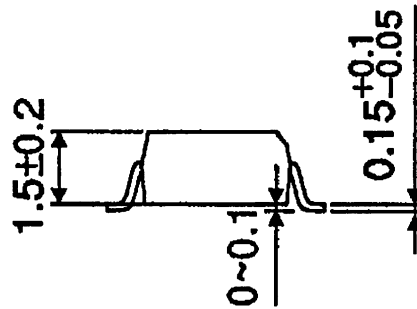
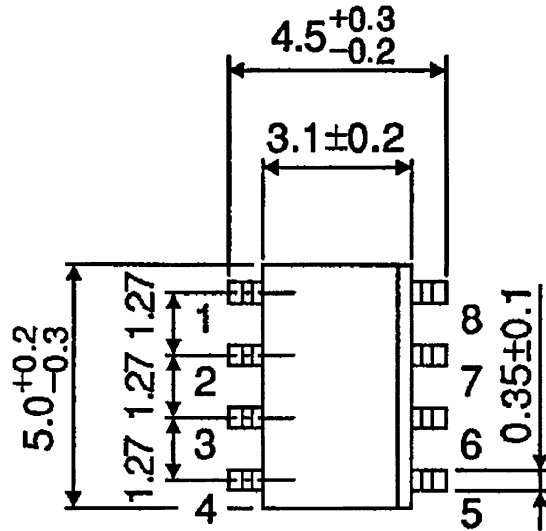

Weight : 0.05g (Typ.)

PACKAGE DIMENSIONS
SSOP8-P-0.65

Unit : mm

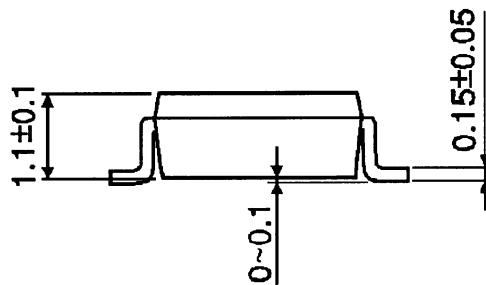
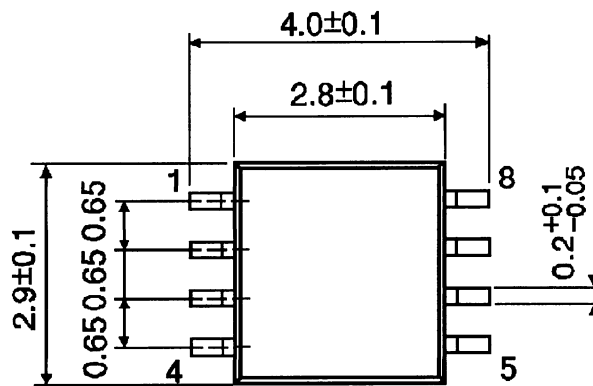

Weight : 0.02g (Typ.)

PACKAGE DIMENSIONS
SSOP8-P-0.50A

Unit : mm

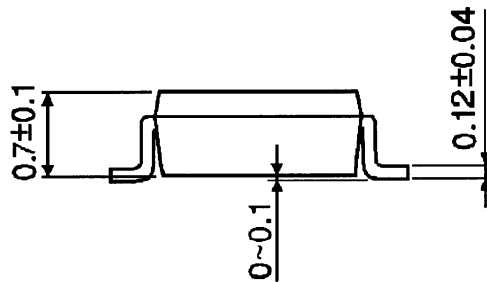
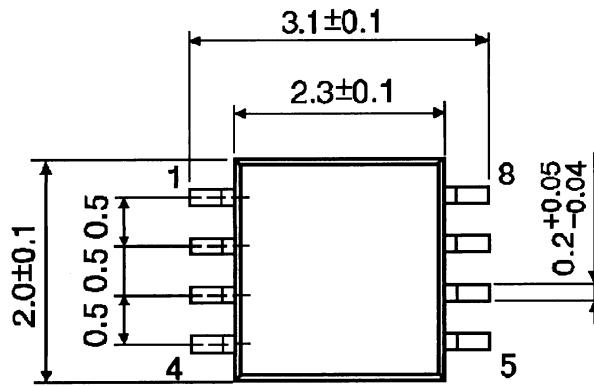

Weight : 0.01g (Typ.)

RESTRICTIONS ON PRODUCT USE

000707EBA

- TOSHIBA is continually working to improve the quality and reliability of its products. Nevertheless, semiconductor devices in general can malfunction or fail due to their inherent electrical sensitivity and vulnerability to physical stress. It is the responsibility of the buyer, when utilizing TOSHIBA products, to comply with the standards of safety in making a safe design for the entire system, and to avoid situations in which a malfunction or failure of such TOSHIBA products could cause loss of human life, bodily injury or damage to property. In developing your designs, please ensure that TOSHIBA products are used within specified operating ranges as set forth in the most recent TOSHIBA products specifications. Also, please keep in mind the precautions and conditions set forth in the "Handling Guide for Semiconductor Devices," or "TOSHIBA Semiconductor Reliability Handbook" etc..
- The TOSHIBA products listed in this document are intended for usage in general electronics applications (computer, personal equipment, office equipment, measuring equipment, industrial robotics, domestic appliances, etc.). These TOSHIBA products are neither intended nor warranted for usage in equipment that requires extraordinarily high quality and/or reliability or a malfunction or failure of which may cause loss of human life or bodily injury ("Unintended Usage"). Unintended Usage include atomic energy control instruments, airplane or spaceship instruments, transportation instruments, traffic signal instruments, combustion control instruments, medical instruments, all types of safety devices, etc.. Unintended Usage of TOSHIBA products listed in this document shall be made at the customer's own risk.
- The products described in this document are subject to the foreign exchange and foreign trade laws.
- The information contained herein is presented only as a guide for the applications of our products. No responsibility is assumed by TOSHIBA CORPORATION for any infringements of intellectual property or other rights of the third parties which may result from its use. No license is granted by implication or otherwise under any intellectual property or other rights of TOSHIBA CORPORATION or others.
- The information contained herein is subject to change without notice.