

X2 DATA SHEET



CONTENTS

1	PRODUCT OVERVIEW	1
1.1	Product Features	1
1.2	Applications	1
1.3	Installation and Dimensions	1
2	SPECIFICATIONS	2
2.1	Product Parameter.....	2
2.2	Electrical Parameter	3
2.3	Interface Definition	3
2.4	Data Communication.....	4
2.5	Motor Control.....	4
2.6	Optical Characteristic.....	4
2.7	Polar Coordinate System Definition	5
2.8	Others.....	5
3	DEVELOPMENT AND SUPPORT	6
4	REVISE	7

1 PRODUCT OVERVIEW

YDLIDAR X2 is a 360° 2D LiDAR(hereinafter referred to as X2) developed by YDLIDAR team. Based on the principle of Triangulation, it is equipped with related optics, electricity, and algorithm design to achieve high-frequency and high-precision distance measurement. The mechanical structure rotates 360 ° to continuously output the angle information as well as the point cloud data of the scanning environment while ranging.

1.1 Product Features

- 360° scan ranging
- High accuracy, stable performance
- Wide measuring range
- Strong resistance to ambient light interference
- Low power consumption, small size, stable performance and long life
- Class I eye safety
- motor speed is adjustable, the proposed speed is 6Hz
- ranging frequency up to 3KHz

1.2 Applications

- Robot navigation and obstacle avoidance
- Robot ROS teaching and research
- Regional security
- Environmental scanning and 3D reconstruction
- Navigation and obstacle avoidance of home service robots/sweeping robots

1.3 Installation and Dimensions

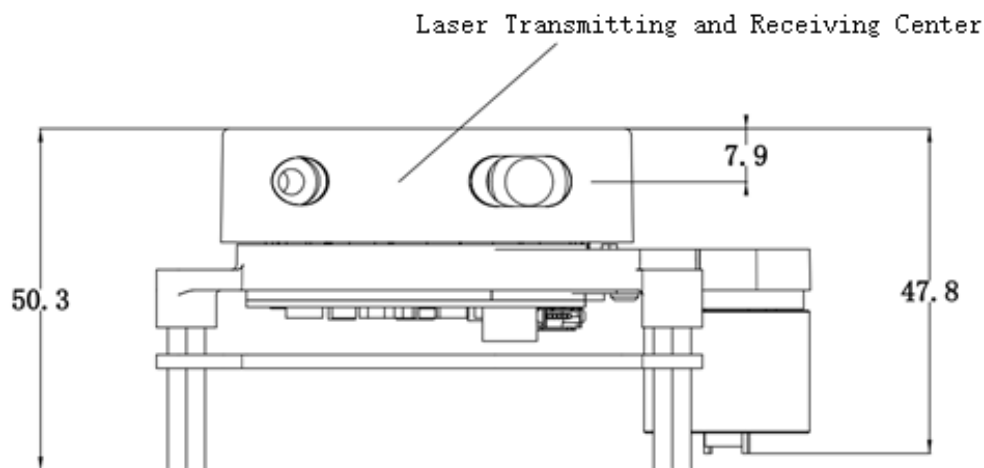

FIG 1 YDLIDAR X2 FRONT STRUCTURE SIZE

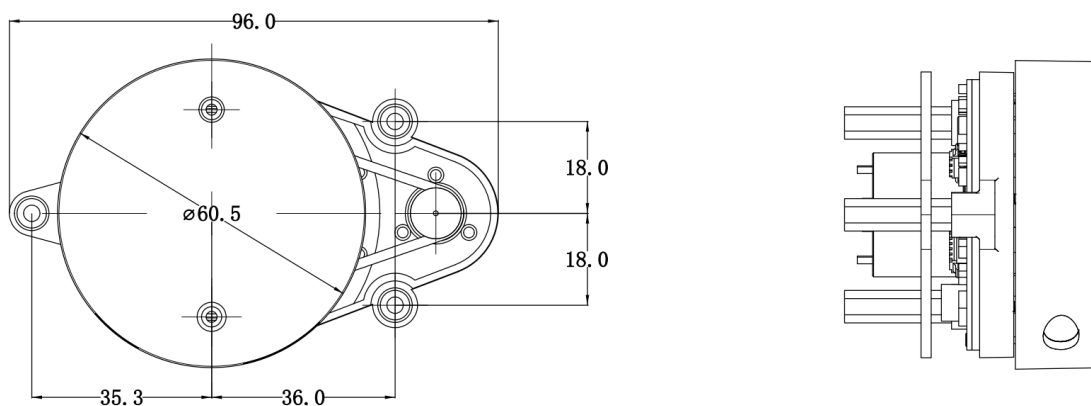

FIG 2 YDLIDAR X2 MECHANICAL DIMENSIONS

2 SPECIFICATIONS

2.1 Product Parameter

CHART 1 YDLIDAR X2 PRODUCT PARAMETER

Item	Min	Typical	Max	Unit	Remarks
Ranging frequency	/	3000	/	Hz	Ranging 3000 times per second
Motor frequency	5	6	8	Hz	Need to connect to PWM signal, recommended to use the speed of 6Hz
Ranging distance	0.12	/	8	m	Indoor environment, 80% Reflectivity
Field of view	/	0-360	/	°	/
Systematic Error	/	2	/	cm	Range≤1m
Statistical Error	/	3.5%	/	/	1m<Range ≤6m
Laser inclination	0.25	1	1.75	°	/
Angle resolution	0.60 (frequency @5Hz)	0.72 (frequency@ 6Hz)	0.96 (frequency @@8Hz)	°	Different motor frequency

Note1: The range and relative accuracy in the above table are factory values, statistical error changes with the actual distance value;

Note2: In the above table, the relative error value represents the accuracy of the lidar measurement,

Statistical Error = (Ranging distance - actual distance)/ actual distance * 100%. LiDAR is a precision equipment, which needs to be protected during use. In the use scenarios of high temperature, high and low temperature or strong vibration, the parameter index of relative error will be relatively larger.

2.2 Electrical Parameter

CHART 2 YDLIDAR X2 ELECTRICAL PARAMETER

Item	Min	Typical	Max	Unit	Remarks
Supply voltage	4.8	5	5.2	V	Excessive voltage might damage the Lidar while low affect normal performance
Startup current	1000	/	/	mA	Instantaneous peak current at start-up
Working current	/	300	500	mA	System work, motor rotation

2.3 Interface Definition

X2 provides MX1.25-4P female connector to realize power and data communication function.

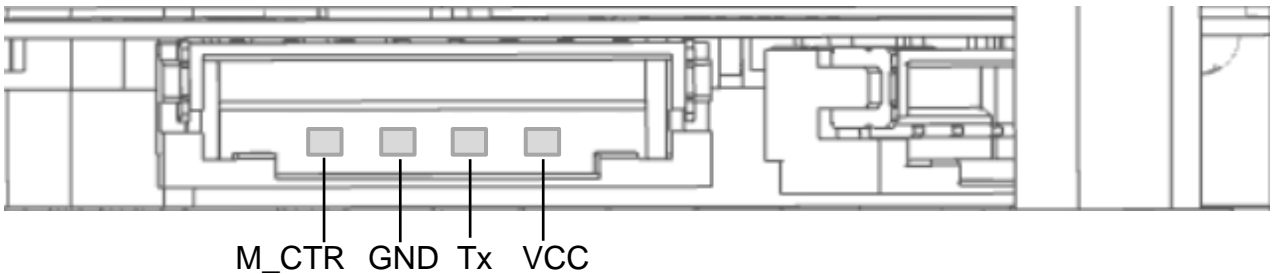

FIG 3 YDLIDAR X2 INTERFACES

CHART 3 YDLIDAR X2 INTERFACE DEFINITION

Pin	Type	Description	Defaults	Range	Remarks
VCC	Power Supply	Positive	5V	4.8V-5.2V	/
Tx	Output	System serial port output	/	/	Data stream: Lidar → Peripherals
GND	Power Supply	Negative	0V	0V	/
M_CTR	Input	Motor speed control terminal	1.8V	0V-3.3V	Voltage speed regulation or PWM speed regulation

2.4 Data Communication

With a 3.3V level serial port (UART), users can connect the external system and the product through the physical interface. After that, you can obtain the real-time scanned point cloud data, device information as well as device status. The communication protocol of parameters are as follows:

CHART 4 YDLIDAR X2 SERIAL SPECIFICATION

Item	Min	Typical	Max	Unit	Remarks
Baud rate	/	115200	/	bps	8-bit data bit, 1 stop bit, no parity
High Signal Level	2.4	3.3	3.5	V	/
Low signal Level	0	0	0.6	V	/

2.5 Motor Control

X2 has its own motor driver with motor speed control function. The peripheral can control the X2 motor by inputting control signals through the M_CTR pin in the interface. M_CTR is the motor speed control signal, which can be adjusted by voltage and can also be debugged by PWM wave. The higher the voltage/the greater the PWM duty cycle, the higher the motor speed.

Among them, the PWM signal of M_CTR has the following requirements:

CHART 5 YDLIDAR X2 MOTOR PWM SIGNAL SPECIFICATION

Item	Min	Typical	Max	Unit	Remarks
PWM frequency	/	10	/	KHz	PWM is a square wave signal
Duty cycle range	0	35%	100%	/	The larger the duty cycle, the faster the speed

2.6 Optical Characteristic

X2 uses an infrared laser that meets FDA Class I eye safety standards. The laser and optical lens finish the transmission and reception of the laser signal to achieve high-frequency ranging while working. To ensure system ranging performance, please keep the laser and optical lens clean. The detailed optical parameters are as follows:

CHART 6 YDLIDAR X2 LASER OPTICAL PARAMETERS

Item	Min	Typical	Max	Unit	Remarks
Laser Wavelength	775	793	800	nm	Infrared band
FDA	⚠ Class I				

2.7 Polar Coordinate System Definition

In order to facilitate secondary development, X2 internally defines a polar coordinate system. The polar coordinates of the system take the center of the rotating core of X2 as the pole, and the specified Angle is positive clockwise. The zero Angle is located directly in front of the X2 motor. Due to individual differences, there is a deviation of $\pm 3^\circ$, as shown in the figure:

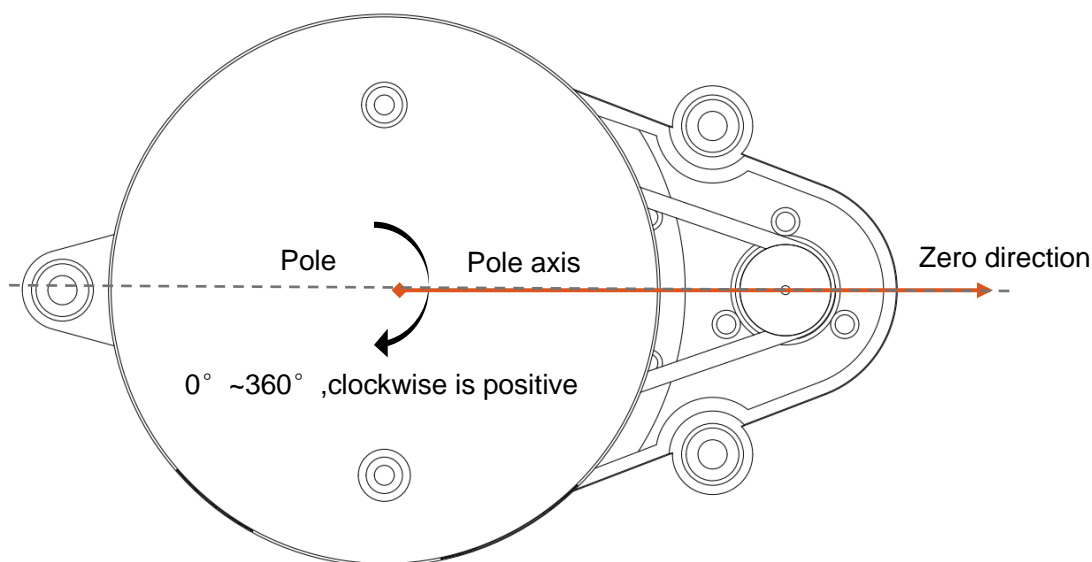

FIG 4 YDLIDAR X2 POLAR COORDINATE SYSTEM DEFINITION

2.8 Others

CHART 7 YDLIDAR X2 OTHERS

Item	Min	Typical	Max	Unit	Remarks
Operating temperature	0	20	40	°C	No condensation
Storage temperature	-10	/	60	°C	With package
Lighting environment	0	550	2000	Lux	For reference only
weight	/	126	/	g	N.W.

3 DEVELOPMENT AND SUPPORT

X2 provides a wealth of software interfaces, which can realize the motor enabling control, speed control, range unit enabling control and output control of the system. On this basis, users can also implement the power control and scan control purpose.

Also, the 3D model of X2 is disclosed. YDLIDAR provides the graphics debugging Workstation under Windows, as well as the corresponding SDK and ROS development kit to users, which could be downloaded from our website: <https://www.ydlidar.com/>.

In order to facilitate users' development, X2 development manual, SDK development manual and ROS user manual are also provided. Please download them from [our website](#).

4 REVISE

Date	Version	Content
2018-06-20	1.0	Compose a first draft
2021-07-22	2.0	Update electrical parameters and serial port specification