

## Descriptions

### 0.5A Non-isolated Regulator



## Features

- No-load input current as low as 0.2mA
- Operating ambient temperature range: -40°C to +85°C
- Up to 95% efficiency
- Output short-circuit protection
- Support the negative output
- Pin compatible with LM78xx series

## Applications

- Industrial control
- Electric power
- Instruments and meters

## Selection Guide

Certification	Part No.	Input Voltage (VDC)*	Output		Full Load Efficiency (%) Vin Min. / Vin Max.	Capacitive Load (μF)Max.
		Nominal (Range)	Voltage (VDC)	Current (mA) Max.		
UL/EN/BS EN	DNKS0.5-7803	24 (4.75-36)	3.3	500	86/80	680
	DNKS0.5-7805	24 (6.5-36)	5.0	500	90/84	680
		12 (7-31)	-5.0	-300	80/81	330
UL/EN/BS EN	DNKS0.5-7809	24 (12-36)	9	500	93/90	680
UL/EN/BS EN	DNKS0.5-7812	24 (15-36)	12	500	94/91	680
		12 (8-24)	-12	-150	84/85	330
	DNKS0.5-7815	24 (19-36)	15	500	95/93	680
		12 (8-21)	-15	-150	85/87	330

Note: For input voltage exceeding 30 VDC, an input capacitor of 22μF/50V is required.

Specifications							
Characteristic	Item	Operating Conditions		Min.	Typ.	Max.	Unit
Input Specifications	No-load Input Current	Positive output		--	0.2	1.5	mA
	Reverse Polarity at Input			Avoid / Not protected			
	Input Filter			Capacitance filter			
Output Specifications	Voltage Accuracy	Full load, input voltage range	3.3VDC output	--	±2	±4	%
			Others	--	±2	±3	
	Linear Regulation	Full load, input voltage range		--	±0.2	±0.4	
	Load Regulation	Nominal input voltage, 10% -100% load	3.3/5 VDC output	--	±0.6	--	%
			Others	--	±0.3	--	
	Ripple & Noise <sup>①</sup>	20MHz bandwidth, nominal input voltage, 10% -100% load		--	20	75	mVp-p
	Temperature Coefficient	Operating ambient temperature -40°C to +85°C		--	--	±0.03	%/°C
	Transient Response Deviation	Nominal input voltage, 25% load step change		--	50	250	mV
	Transient Recovery Time			--	0.2	1	ms
Short-circuit Protection	Nominal input voltage		Continuous, self-recovery				
General Specifications	Operating Temperature <sup>②</sup>	See Fig. 1		-40	--	+85	°C
	Storage Temperature			-55	--	+125	
	Pin Soldering Resistance Temperature	Soldering spot is 1.5mm away from case for 10 seconds		--	--	+260	
	Storage Humidity	Non-condensing		5	--	95	%RH
	Switching Frequency	Full load, nominal input voltage		550	--	850	kHz
	MTBF	MIL-HDBK-217F@25°C		2000	--	--	k hours
Mechanical Specifications	Case Material	Black plastic; flame-retardant and heat-resistant (UL94 V-0)					
	Dimensions	11.60 x 7.55 x 10.16 mm					
	Weight	1.8g (Typ.)					
	Cooling Method	Free air convection					

Note:  
 ①The "parallel cable" method is used for ripple and noise test,  
 ②With light loads at or below 10%, Ripple & Noise for 3.3V/5V output parts increases to 150mVp-p max, and for 9V/12V/15V output parts to 2%Vo max.

## Electromagnetic Compatibility (EMC)

Electromagnetic Compatibility (EMC)	Emissions	CE	CISPR32/EN55032	CLASS B (see Fig. 5-② for recommended circuit)		
		RE	CISPR32/EN55032	CLASS B (see Fig. 5-② for recommended circuit)		
	Immunity	ESD	IEC/EN 61000-4-2	Contact ±4KV		perf. Criteria B
		RS	IEC/EN 61000-4-3	10V/m		perf. Criteria A
		EFT	IEC/EN 61000-4-4	±1KV (see Fig. 5-① for recommended circuit)		perf. Criteria B
		Surge	IEC/EN 61000-4-5	line to line ±1KV (see Fig. 5-① for recommended circuit)		perf. Criteria B
		CS	IEC/EN 61000-4-6	3Vr.m.s		perf. Criteria A

## Characteristic Curve

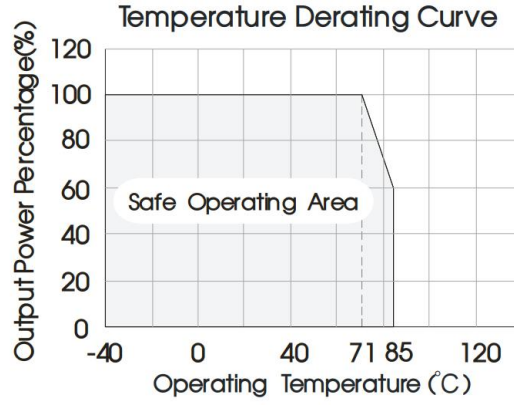
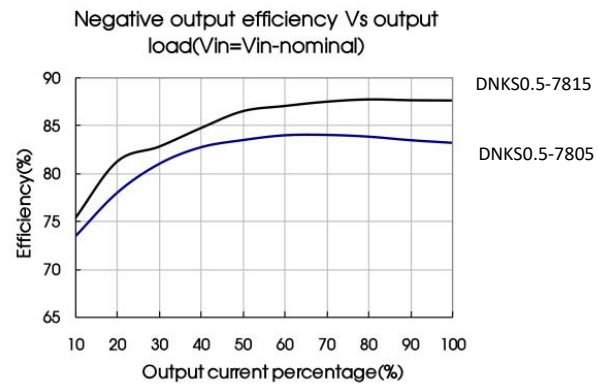
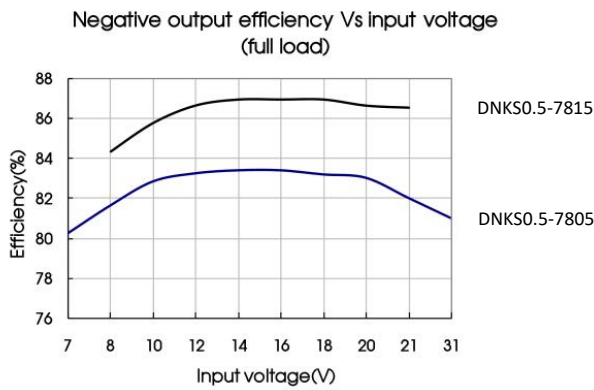
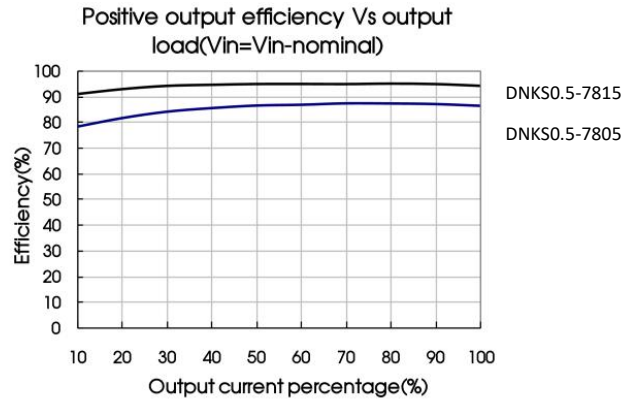
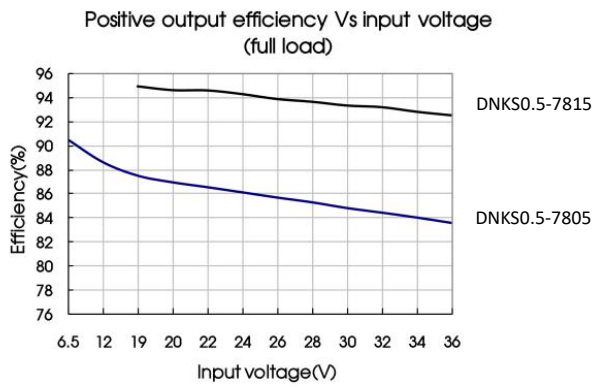

Fig. 1



## Design Reference

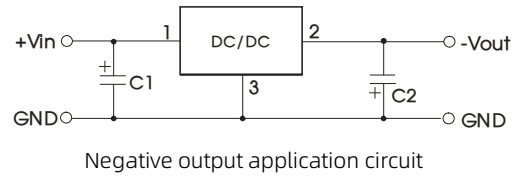
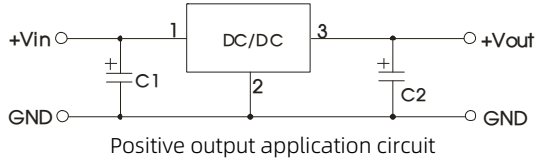

Fig. 2 Typical application circuit

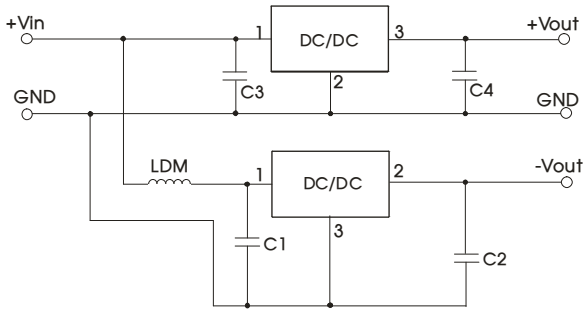

Fig. 3 Positive and Negative output application circuit

Part No.	C1/C3 (ceramic capacitor)	C2/C4 (ceramic capacitor)
DNKS0.5-7803	10 $\mu$ F/50V	22 $\mu$ F/10V
DNKS0.5-7805		22 $\mu$ F/10V
DNKS0.5-7809		22 $\mu$ F/16V
DNKS0.5-7812		22 $\mu$ F/25V
DNKS0.5-7815		22 $\mu$ F/25V

Note:

- 1.The required capacitors C1 and C2 (C3 and C4) must be connected as close as possible to the terminals of the module;
- 2.Refer to Table 1 for C1 and C2 (C3 and C4) capacitor values. For certain applications, increased values and/or tantalum or low ESR electrolytic capacitors may also be used instead;
- 3.When using configurations as shown in figure 3, we recommended to add an inductor (LDM) with a value of up to 10 $\mu$ H which helps reducing mutual interference;
- 4.Converter cannot be used for hot swap and with output in parallel;
- 5.To further reduce the output ripple and noise, we suggested the use of a "LC" filter at the output terminals, with an inductor value (L) of 10 $\mu$ H-47 $\mu$ H.

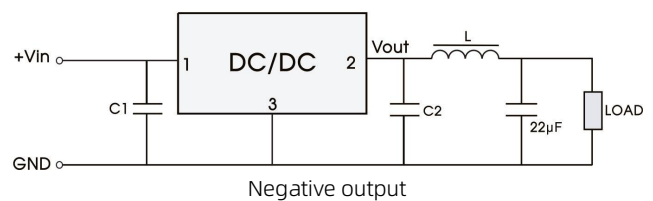
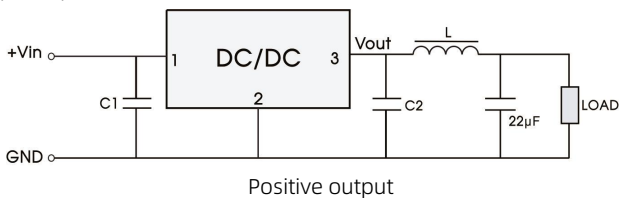

Fig. 4 Using the "LC" output filter application

## 2. EMC compliance recommended circuit

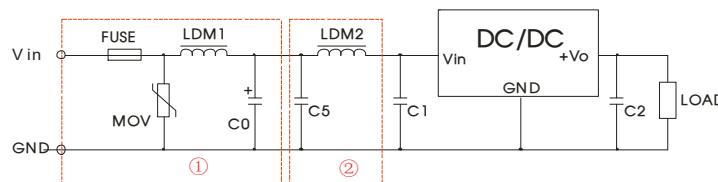

Fig. 5 EMC recommended circuit

FUSE	MOV	LDM1	C0	C1/C2	C5	LDM2
Select fuse value according to actual input current	S20K30	82 $\mu$ H	680 $\mu$ F /50V	Refer to table 1	4.7 $\mu$ F /50V	12 $\mu$ H

Note:For EMC tests we use Part ① in Fig. 5 for immunity and part ② for emissions test.Selecting based on needs.

## Dimensions and Recommended Layout

THIRD ANGLE PROJECTION

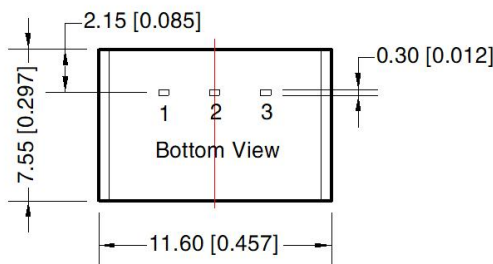
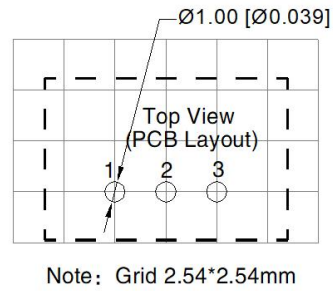
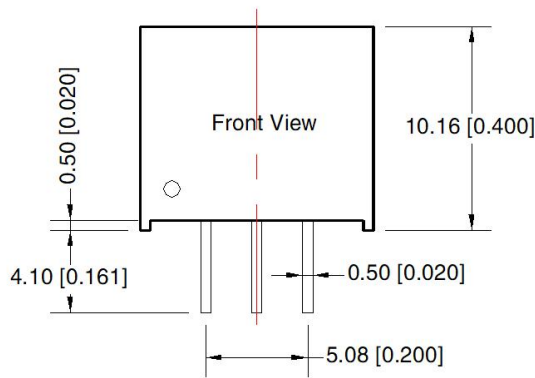

Pin-Out		
Pin	Positive Output	Negative Output
1	Vin	Vin
2	GND	-Vo
3	+Vo	GND

Note:  
 Unit: mm[inch]  
 Pin diameter tolerances:  $\pm 0.10$  [ $\pm 0.004$ ]  
 General tolerances:  $\pm 0.50$  [ $\pm 0.020$ ]

- Note:
1. If the product is not operated within the required output load range, the product performance cannot be guaranteed to comply with all parameters in the datasheet;
  2. Unless otherwise specified, parameters in this datasheet were measured under the conditions of  $T_a=25^\circ\text{C}$ , humidity<75% with nominal input voltage and rated output load;
  3. All index testing methods in this datasheet are based on our company corporate standards;
  4. Products are related to laws and regulations: see "Features" and "EMC";
  5. Our products shall be classified according to ISO14001 and related environmental laws and regulations, and shall be handled by qualified units.