

Descriptions

10W isolated, DC/DC Converter



RoHS



EN62368-1



BS EN62368-1

Features

- Ultra-wide 12:1 input voltage range: 14 -160VDC
- High efficiency up to 84%
- Reinforced insulation, I/O isolation test voltage 3K VAC
- Operating ambient temperature range -40°C to +105°C
- Input under-voltage protection, output over-voltage, over-current, short-circuit protection, over-temperature protection
- Industry standard package and pin-out
- Meets EN50155 and AREMA standards
- Meets EN45545 standards

Applications

- Vehicle-mounted switches
- Train control systems
- Traction control systems

Selection Guide

Certification	Part No.	Ctrl Logic [®]	Input Voltage (VDC)		Output		Full Load Efficiency(%) [®] Min./Typ.	Max. Capacitance Load(μF)
			Typ (Range)	Max. [®]	Voltage (VDC)	Current (mA) (Max./Min.)		
EN/BS EN	DRULD10-F1D03	P	110 (14-160)	160	3.3	3030/0	78/80	1000
--	DRULD10-F1D03F/H							
EN/BS EN	DRULD10-F1D05				5	2000/0	78/80	1000
--	DRULD10-F1D05F/H							
EN/BS EN	DRULD10-F1D12				12	833/0	82/84	470
--	DRULD10-F1D12F/H							
EN/BS EN	DRULD10-F1D15				15	667/0	82/84	330
--	DRULD10-F1D15F/H							
EN/BS EN	DRULD10-F1D24				24	417/0	82/84	220
--	DRULD10-F1D24F/H							
EN/BS EN	DRULD10-F1D28				28	357/0	82/84	220
--	DRULD10-F1D28F/H							
EN/BS EN	DRULD10-F1D48	48	208/0	82/84	150			

--	DRULD10-F1D48F/H						
EN/BS EN	DRULD10-F1D54			54	185/0	82/84	150
--	DRULD10-F1D54F/H						

Note:

- ① "P" means positive logic, "N" means negative logic;
- ② Exceeding the maximum input voltage may cause permanent damage;
- ③ This efficiency value is the full load efficiency measured at the nominal 48V input voltage at room temperature;
- ④ When the product with input at 14V~16.8V / 160V-200V, the working time is 0.1s and 1s respectively;
- ⑤ When starting with a capacitive load, Trim is only applicable to the input voltage range 16.8V-160V.

Specifications

Product Specifications	Item	Operating Conditions		Min.	Typ.	Max.	Unit
Input Specifications	Input Current (full load)	24V input	3.3V, 5V, 12V, 15V Output	--	550	625	mA
			24V, 28V, 48V, 54V Output	--	510	525	
		36V input	3.3V, 5V, 12V, 15V Output	--	356	390	
			24V, 28V, 48V, 54V Output	--	340	350	
		48V input	3.3V, 5V, 12V, 15V Output	--	265	280	
			24V, 28V, 48V, 54V Output	--	250	260	
		72V input	3.3V, 5V, 12V, 15V Output	--	175	195	
			24V, 28V, 48V, 54V Output	--	170	180	
		96V input	3.3V, 5V, 12V, 15V Output	--	135	150	
			24V, 28V, 48V, 54V Output	--	130	135	
		110V input	3.3V, 5V, 12V, 15V Output	--	115	135	
			24V, 28V, 48V, 54V Output	--	110	115	
	Reflected Ripple Current	Nominal input voltage		--	150	190	VDC
	Surge Voltage (1sec. max.)			-0.7	--	200	
	Start-up Voltage			--	--	14	
Start-up Time			--	50	100	ms	
No-load input power	Ctrl pin open or pulled high, DC-DC ON (14-160VDC)		--	1.2	2.2	W	
Idle input power	Ctrl pin pulled low to GND, DC-DC OFF (14-160VDC)		--	0.7	1.6		
Ctrl ^①	Module on		Ctrl pin open or pulled high (3.5-12VDC)				
	Module off		Ctrl pin pulled low to -Vin (0-1.2VDC)				
Input Under-voltage protection			10	12	--	VDC	
Output Specifications	Voltage Accuracy	Nominal input voltage, 5%-100% load	3.3V, 5V output	--	±1	±3	%
			Other output				
	Linear Regulation	Input voltage variation from low to high at full load		--	±0.5	±1	
	Load Regulation	Nominal input voltage, 5%-100% load		--	±0.5	±1	
Transient Recovery Time	25% load step change		--	300	500	μs	

	Transient Response Deviation	@25°C	3.3V, 5V output	--	±5	±10	%
			Other output	--	±3	±5	
	Temperature Coefficient	Nominal input voltage, full load		--	--	±0.03	%/°C
	Ripple & Noise ^②	20MHz bandwidth, 5%-100%load	3.3V, 5V, 12V, 15V output	--	100	150	mVp-p
			Other output	--	150	200	
	Trim			90	--	110	%Vo
	Over-temperature Protection	Max. Case Temperature		105	--	130	°C
	Over-voltage Protection	Input voltage range		110	--	--	%Vo
Over-current Protection			110	--	260	%Io	
Short-circuit Protection			Hiccup, continuous, self-recovery				
General Specifications	Isolation	Electric Strength Test for 1 minute with a leakage current of 5mA max	Input-output	3000	--	--	VAC
			Input-case	2800	--	--	
			Output-case	2100	--	--	
	Insulation Resistance	Input-output resistance at 500VDC		1000	--	--	MΩ
	Isolation Capacitance	Input-output capacitance at 100KHz/0.1V		--	1500	--	pF
	Operating Temperature			-40	--	105	°C
	Storage Temperature			-55	--	125	
	Pin Soldering Resistance Temperature	Soldering spot is 1.5mm away from case for 10 seconds		--	--	300	
	Storage Humidity	Non-condensing		5	--	95	%RH
	Switching Frequency	PWM mode		--	170	--	kHz
	MTBF	IEC 61709 @25°C		1000	--	--	k hours
	Cooling Test			EN60068-2-1			
	Dry Heat			EN60068-2-2			
	Damp Heat			EN60068-2-30			
	Shock and Vibration Test			IEC/EN61373 Class B			
	Pollution level			PD 3			
	Fire & smoke compliance			EN45545-2, HL3			
	Salt mist test			EN60068-2-11, Ka			
Altitude ^③			Altitude: ≤5000m, Atmospheric pressure: 50 ~ 110KPa				
Mechanical Specifications	Case Material	Aluminum alloy case; Black plastic bottom, flame-retardant and heat-resistant (UL94 V-0)					
	Dimension	Without heat sink		50.80 x 25.40 x 11.80 mm			
		With H heat sink		50.80 x 25.40 x 22.80 mm			
		With F heat sink		50.80 x 40 x 11.80 mm			
	Weight	Without heat sink		41.5g (Typ.)			
		With H heat sink		55.0g (Typ.)			
With F heat sink		43.0g (Typ.)					
Cooling Method	Conduction cooling or forced air cooling Free air convection cooling with additional heat sink						

Note: Note:

①The Ctrl pin voltage is referenced to input GND.

②The "Tip and barrel method" is used for ripple and noise test, for details please refer to Fig.1.

③If the product is used at an altitude above 2000m, it is necessary to ensure that the surface temperature of the product is lower than 130°C.

Electromagnetic Compatibility (EMC) (EN50121-3-2)

Emissions	CE	EN50121-3-2	150kHz-500kHz	99dBuV (see Fig. 4 for recommended circuit)	
			500kHz-30MHz	93dBuV (see Fig. 4 for recommended circuit)	
		EN55032	150kHz-500kHz	79dBuV (see Fig. 4 for recommended circuit)	
			500kHz-30MHz	73dBuV (see Fig. 4 for recommended circuit)	
	RE	CISPR16-2-3	30MHz-230MHz	40dBuV/m at 10m (see Fig. 4 for recommended circuit)	
			230MHz-1GHz	47dBuV/m at 10m (see Fig. 4 for recommended circuit)	
1GHz-6GHz			47dBuV/m at 10m (see Fig. 4 for recommended circuit)		
Immunity	ESD	EN61000-4-2	Contact ±6kV/Air ±8kV		perf. Criteria A
	RS	EN61000-4-3	80 - 800MHz	20V/m (see Fig. 4 for recommended circuit)	perf. Criteria A
			800 - 1000MHz	20V/m (see Fig. 4 for recommended circuit)	
			1400 - 2000MHz	10V/m (see Fig. 4 for recommended circuit)	
			2000 - 2700MHz	5V/m (see Fig. 4 for recommended circuit)	
			5100 - 6000MHz	3V/m (see Fig. 4 for recommended circuit)	
	EFT	EN61000-4-4	±2kV 5/50ns 5kHz	(see Fig. 4 for recommended circuit)	perf. Criteria A
	Surge	EN61000-4-5	line to line ±1kV (42Ω, 0.5μF) (see Fig. 4 for recommended circuit)		perf. Criteria A
line to line ±1kV (2Ω, 18μF) (see Fig. 4 for recommended circuit)					
CS	EN61000-4-6	0.15MHz-80MHz	10V r.m.s (see Fig. 4 for recommended circuit)	perf. Criteria A	

Electromagnetic Compatibility (EMC) (AREMA)

Emissions	CE	CISPR16-2-1	150kHz-500kHz	79dBuV (see Fig. 4 for recommended circuit)	
		CISPR16-1-2	500kHz-30MHz	73dBuV (see Fig. 4 for recommended circuit)	
	RE	CISPR16-2-3	30MHz-230MHz	40dBuV/m at 10m (see Fig. 4 for recommended circuit)	
			230MHz-1GHz	47dBuV/m at 10m (see Fig. 4 for recommended circuit)	
Immunity	ESD	IEC61000-4-2	Contact ±6kV/ Air ±8kV		perf. Criteria A
	RS	IEC61000-4-3	80 - 1000MHz	10V/m (see Fig. 4 for recommended circuit)	perf. Criteria A
			160 - 165MHz	20V/m (see Fig. 4 for recommended circuit)	
			450 - 470MHz	20V/m (see Fig. 4 for recommended circuit)	
			800 - 960MHz	20V/m (see Fig. 4 for recommended circuit)	
			1400 - 2000MHz	20V/m (see Fig. 4 for recommended circuit)	
	2100 - 2500MHz	5V/m (see Fig. 4 for recommended circuit)			
	EFT	IEC61000-4-4	±2kV 5/50ns 5kHz	(see Fig. 4 for recommended circuit)	perf. Criteria A
Surge	IEC61000-4-5	line to line ±2kV (2Ω, 18μF) (see Fig. 4 for recommended circuit)		perf. Criteria A	
CS	IEC61000-4-6	0.15MHz-80MHz	10V r.m.s (see Fig. 4 for recommended circuit)	perf. Criteria A	

Typical Performance Curves

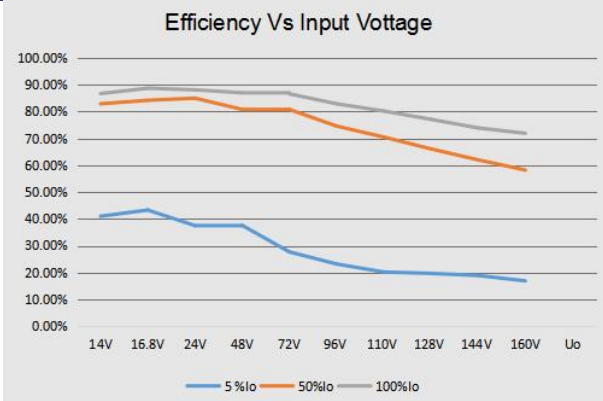

DRULD10-F1D54(F/H) Efficiency curve of input voltage
(normal temperature)

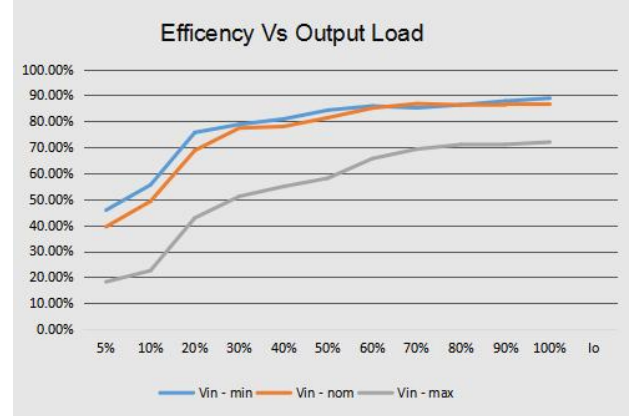

DRULD10-F1D54(F/H) Efficiency curve of output load
(normal temperature)

DRULD10-F1D03/05/12/15(F/H)

Temperature Derating Curve

(Vin=110V, Without wind)

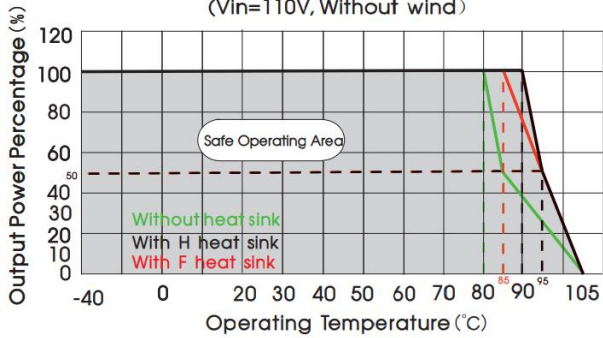

DRULD10-F1D24/28/48/54(F/H)

Temperature Derating Curve

(Vin=110V, Without wind)

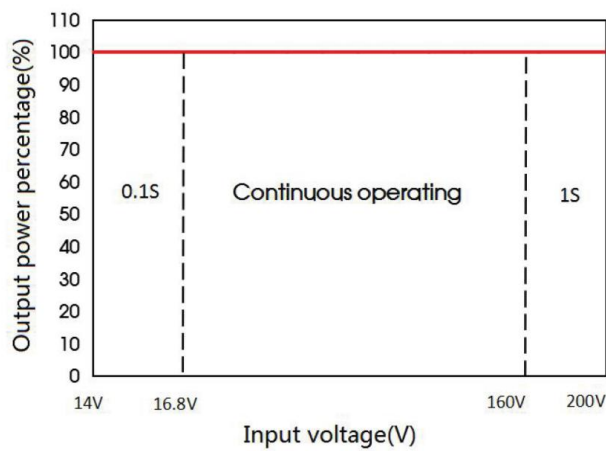
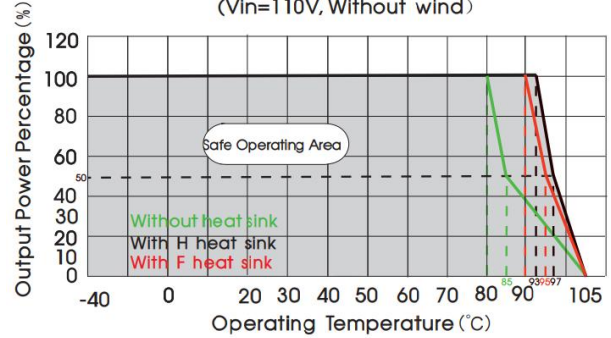

Design Reference

1. Ripple & noise

All the DC-DC converters of this series are tested before delivery using the recommended circuit shown in Fig. 1.

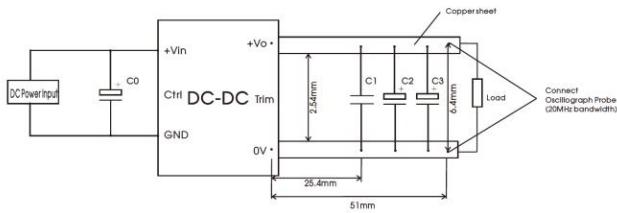

Fig.1

Output Voltage	Capacitors Value	C0(μF)	C1(μF)	C2(μF)	C3(μF)
3.3V/5VDC	100μF /250V		1μF/10V	10μF/50V	680μF/16V
12VDC			1μF/16V		330μF/25V
15VDC			1μF/25V		
24VDC			1μF/50V	100μF/50V	
28VDC					
48VDC			1μF/100V	10μF/63V	82μF/63V
54VDC			1μF/100V		

2. Typical application

- We recommended using EMC circuit, otherwise please ensure that at least a 100μF electrolytic capacitors is connected at the input in order to ensure adequate voltage surge suppression and protection.
- Output ripple can be further reduced by appropriately increasing the output capacitor values C_{in} , C_{out} and/or by selecting capacitors with a low ESR (equivalent series resistance). Also make sure that the capacitance is not exceeding the specified max. capacitance load value of the product.
- The recommended circuit for Ctrl function please refer to Fig.2.

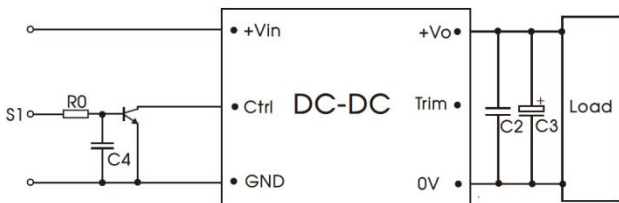

Fig.2

Components	Value	Recommended
R0	10K	--
C4	0.1μF	Voltage≥25V
Q1	Ic≥10mA	Voltage≥30V

3. Trim function for output voltage adjustment (open if unused)

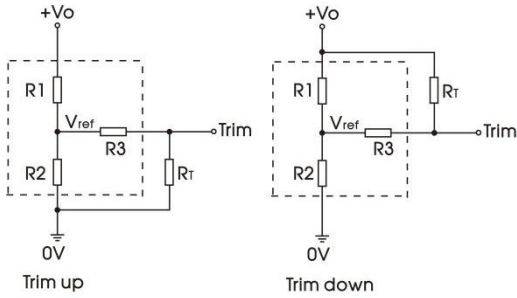

Fig.3

Trim resistor connection (dashed line shows internal resistor network)

Calculation formula of Trim resistance:

$$\text{Trim up : } R_T = \frac{a * R_2}{R_2 - a} - R_3$$

$$\text{Trim down : } R_T = \frac{b * R_1}{R_1 - b} - R_3 \quad b = \frac{(V_0 - V_{ref}) * R_2}{V_{ref}}$$

Note:

Table 1 Values of R1, R2, R3, Vref;

R_T[kΩ]: Resistance of Trim;

a,: self-defined parameter, accurate to two decimal places;

V_o: Output voltage change;

Table 1

Vo Res	3.3(VDC)	5(VDC)	12(VDC)	15(VDC)	24(VDC)	28(VDC)	48(VDC)	54(VDC)
R1(KΩ)	3.974	9.09	11.57	15.12	16.08	24	46.79	59.73
R2(KΩ)	2.4	3	3	3	5	5	3.75	3.75
R3(KΩ)	4	4	12.4	12.4	18.2	20	20	11.2
Vref(V)	1.24	1.24	2.5	2.5	2.5	2.5	2.5	2.5

Practical Example trim up +10% for 12V output:

$$a = \frac{2.5 * 11.57}{13.2 - 2.5} = 2.7$$

$$R_T = \frac{2.7 * 3}{3 - 2.7} - 4 = 27K\Omega$$

R_T according to E24≈27kΩ

Practical Example trim down -10% for 12V output:

$$b = \frac{(10.8 - 2.5) * 3}{2.5} = 9.96$$

$$R_T = \frac{9.96 * 11.57}{11.57 - 9.96} - 12.4 = 59.18K\Omega$$

R_T according to E24≈62kΩ

4. EMC compliance circuit

EMC recommended circuit and parameters when the shell is not connected to PE:

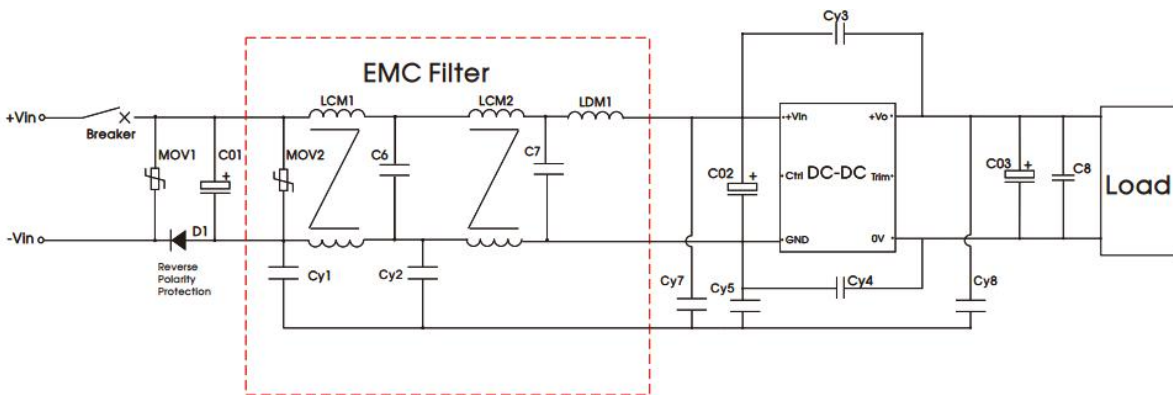

Fig.4

Components Value	CY3	CY4	CY5	CY7, CY8	MOV1	D1
Matching Power Output Voltage						
3.3V	2200 pF / 400VAC	4700 pF / 400VAC	2200 pF / 400VAC	1000 pF / 400VAC	10D221K	16A Withstand voltage ≥600V
5V						
12V						
15V						
24V						
28V						
48V						
54V						
Breaker	The Breaker value varies with different power modules and must be selected in accordance with the specified input current of the corresponding power converter, but not exceeding the filter specifications.					

Note: A ferrite core on the power lines and load lines can ensure a better EMI test margin.

EMC Filter		
Component	Value	Recommended Component
C6, C7	0.1μF	Voltage≥250V
LCM1, LCM2	1.2mH	CM inductor
LDM1	4.7μH	DM inductor
CY1, CY2	1000 pF / 400VAC	Y1 safety capacitor
MOV1	TVR10221KSERW	Varistor
MOV2	7D221K	Varistor

Surge Standard	Components	Value	Recommended Component
line to line ±1kV (42Ω, 0.5μF)	C01	220μF	Voltage≥200V
	C02	220μF	Voltage≥200V
line to line ±2kV (2Ω, 18μF)	C01	330μF	Voltage≥200V
	C02	220μF	Voltage≥200V

Note : Reducing C01\C02 will affect the EMI margin, please select the reference value according to the actual situation.

5. Recommended capacitance for holding time

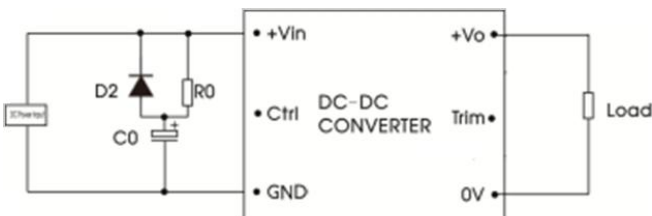

Fig.5

Recommended formula for calculating capacitance:

$$C_0 = \frac{2P_o \Delta t}{(V_{input}^2 - V_{shutdown}^2) \cdot \eta} \times 10^3$$

Remark:

PO(W): Output power;

η: Efficiency;

Δt(ms): Power-down retention time

10ms power off holding time reference table:

V _{in} (V)		24	36	48	72	96	110
P _o (W)		10	10	10	10	10	10
Turn-off voltage (V)		14	14	14	14	14	14
D2		10A/250V					
R0		200Ω/10W					
C0 (μF)	Δt: 10ms	1100	400	220	100	47	35
V _{co}		35V	50V	63V	100V	150V	150V

DRULD10-F1Dxx Dimensions and Recommended Layout

THIRD ANGLE PROJECTION

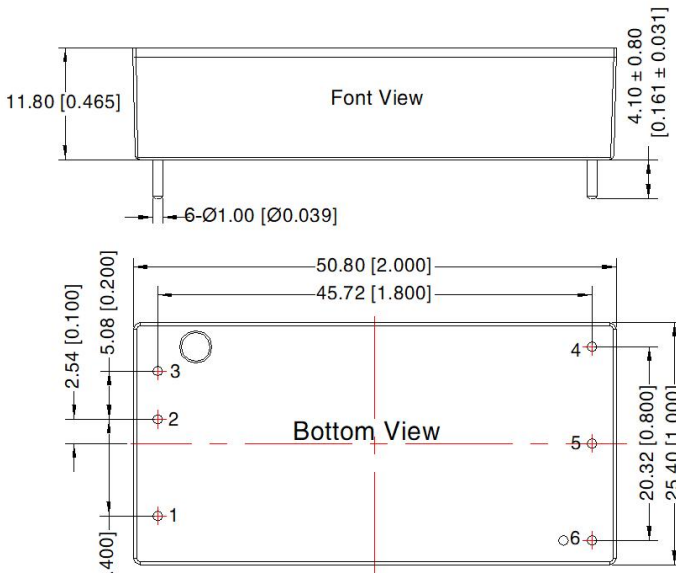

Note:
 Unit: mm[inch]
 Pin diameter tolerances: ± 0.10 [± 0.004]
 General tolerances: ± 0.50 [± 0.020]

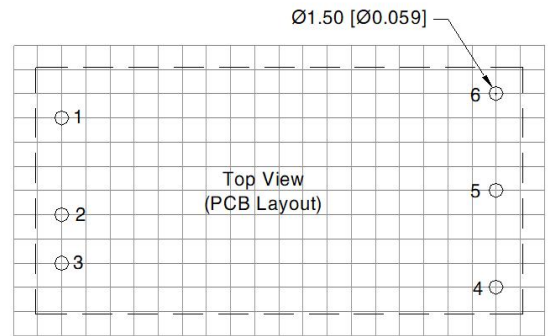

Note: Grid 2.54*2.54mm

Pin-Out	
Pin	Mark
1	Ctrl
2	GND
3	V _{in}
4	+V _o
5	0V
6	Trim

DRULD10-F1DxxF Dimensions and Recommended Layout

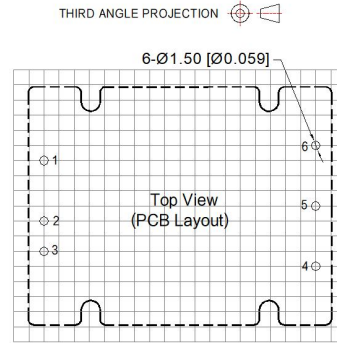
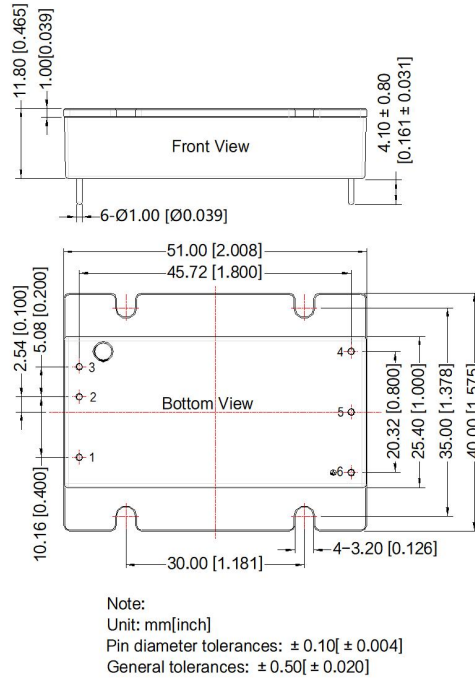

Pin-Out	
Pin	Mark
1	Ctrl
2	GND
3	Vin
4	+Vo
5	0V
6	Trim

DRULD10-F1DxxH Dimensions and Recommended Layout

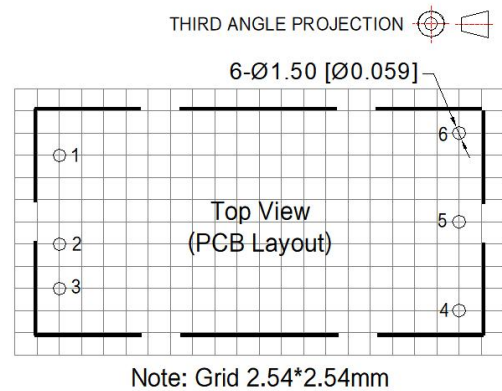
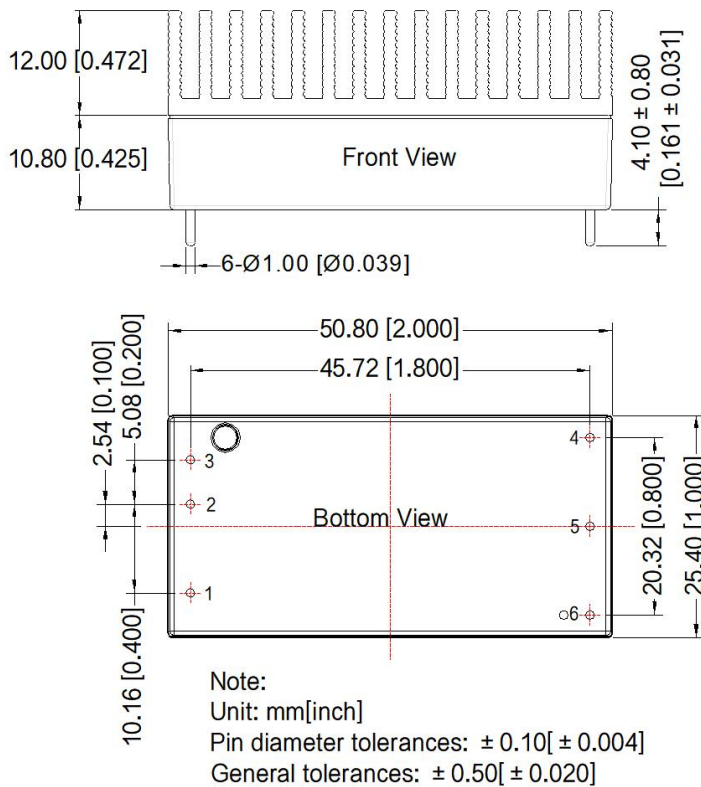

Pin-Out	
Pin	Mark
1	Ctrl
2	GND
3	Vin
4	+Vo
5	0V
6	Trim

Note:

1. The maximum capacitive load offered were tested at nominal input voltage 16.8V-160V and full load;
2. Unless otherwise specified, data in this datasheet should be tested under the conditions of $T_a=25^{\circ}\text{C}$, humidity < 75%RH with nominal input voltage and rated load;
3. All index testing methods in this datasheet are based on our company corporate standards;
4. We can provide product customization service and match filter module;
5. Products are related to laws and regulations: see "Features" and "EMC";
6. Our products shall be classified according to ISO14001 and related environmental laws and regulations, and shall be handled by qualified units.