

Descriptions

250W isolated, DC/DC Converter



RoHS



EN62368-1



BS EN62368-1

Features

- Ultra-wide input voltage range: 40 -160VDC
- High efficiency up to 90%
- Reinforced insulation, I/O isolation test voltage 3k VAC
- Operating ambient temperature range -40°C to +105°C
- Input under-voltage protection, output over-voltage, over-current, short-circuit protection, over-temperature protection
- Industry standard 1/2-Brick package and pin-out

Applications

- Centralized lighting, Air conditioning
Related in on-board equipment

Selection Guide

Certification	Part No. ^①	Ctrl Logic ^②	Input Voltage (VDC)			Output		Full Load Efficiency (%) Min./Typ.	Max. Capacitive Load (μF)
			Nominal	Range	Max. ^③	Voltage (VDC)	Current (mA) Max./Min.		
EN/BS EN	DRWHB250-F1D05	P	110	40-66	170	5	40000/0	87/88	22000
				66-160					
EN/BS EN	DRWHB250-F1D12	P		40-66		12	16670/0	88/90	10000
				66-160			20840/0		
EN/BS EN	DRWHB250-F1D15	P		40-66		15	13330/0	88/90	6800
				66-160			16670/0		
EN/BS EN	DRWHB250-F1D24	P		40-66		24	8330/0	88/90	4000
				66-160			10420/0		
EN/BS EN	DRWHB250-F1D48	P		40-66		48	4160/0	88/90	680
				66-160			5200/0		
EN/BS EN	DRWHB250-F1D54	P		40-66		54	3700/0	88/90	680
				66-160			4630/0		

Note:

①Use "H" suffix for heat sink mounting. "E5" suffix for chassis mounting. We recommend to choose modules with a heat sink for enhanced heat dissipation and applications with extreme temperature requirements;

②" P" means positive logic, " N" means negative logic;

③Exceeding the maximum input voltage may cause permanent damage.

Specifications

Product Specifications	Item	Operating Conditions		Min.	Typ.	Max.	Unit
Input Specifications	Input Current (full load/no-load)	Nominal input voltage	5V output	--	2582/50	2612/70	mA
			Others	--	2526/50	2582/70	
	Reflected Ripple Current	Nominal input voltage		--	100	--	VDC
	Surge Voltage (1sec. max.)			-0.7	--	185	
	Start-up Voltage			--	--	40	
	Input Under-voltage Protection			32	36	--	
	Start-up Time	Nominal input voltage, constant resistance load		--	40	100	ms
	Input Filter			Pi filter			
	Hot Plug			Unavailable			
	Ctrl ^①	Module on		Ctrl open circuit or connected to TTL high level (3.5-12VDC)			
Module off		Ctrl pin connected to -Vin or low level (0-1.2VDC)					
Input current when off		--	5	10	mA		
Output Specifications	Voltage Accuracy			--	±1	±3	%
	Linear Regulation	Input voltage variation from low to high at full load		--	±0.2	±0.5	
	Load Regulation	Nominal input voltage, 0% - 100% load	5V output	--	±0.8	±1.0	
			Others	--	±0.4	±0.5	
	Transient Recovery Time			--	200	500	μs
	Transient Response Deviation	25% load step change @25°C		--	±3	±5	%
	Temperature Coefficient	Full load		--	--	±0.03	%/°C
	Ripple & Noise ^②	20MHz bandwidth, 0% - 100%load		--	120	200	mVp-p
	Trim			90	--	110	%Vo
	Sense			--	--	105	
	Over-temperature Protection	Max. Case Temperature		--	105	115	°C
	Over-voltage Protection	Input voltage range		110	130	160	%Vo
	Over-current Protection	43VDC - 66VDC		110	160	220	%Io
66VDC - 160VDC		110	140	150			
Short-circuit Protection			Continuous, self-recovery				
General Specifications	Isolation	Electric Strength Test for 1 minute with a leakage current of 5mA max	Input - output	3000	--	--	VAC
			Input - case	1500	--	--	
			Output - case	1500	--	--	
	Insulation Resistance	Input-output resistance at 500VDC		100	--	--	MΩ
Isolation Capacitance	Input-output capacitance at 100KHz/0.1V		--	1000	--	pF	

	Operating Temperature	See temperature derating curves	-40	--	+105	°C
	Storage Temperature		-55	--	+125	
	Storage Humidity	Non-condensing	5	--	95	%RH
	Pin Soldering Resistance Temperature	Wave-soldering, 10 seconds	--	--	260	°C
		Soldering spot is 1.5mm away from case for 10 seconds	--	--	300	
	Cooling Requirement		EN60068-2-1			
	Dry-heat Requirement		EN60068-2-2			
	Damp-heat Requirement		EN60068-2-30			
	Shock And Vibration		IEC/EN61373 - Category 1, Grade B			
	Switching Frequency	PFM mode	--	260	--	kHz
	MTBF	MIL-HDBK-217F@25°C	1000	--	--	k hours
Mechanical Specifications	Case Material	Aluminum alloy case; Black plastic bottom, flame-retardant and heat-resistant (UL94 V-0)				
	Dimension	DRWHB250-F1Dxx	61.00 x 57.90 x 13.80mm			
		DRWHB250-F1DxxH	62.00 x 58.00 x 31.80mm			
		DRWHB250-F1DxxE5	135.00 x 70.00 x 22.40mm			
		DRWHB250-F1DxxHE5	135.00 x 70.00 x 40.40mm			
	Weight	DRWHB250-F1Dxx	135g (Typ.)			
		DRWHB250-F1DxxH	185g (Typ.)			
		DRWHB250-F1D05/12/15E5	235g (Typ.)			
		DRWHB250-F1D05/12/15HE5	285g (Typ.)			
		DRWHB250-F1D24/48/54E5	214g (Typ.)			
DRWHB250-F1D24/48/54HE5	264g (Typ.)					
Cooling Method	Free air convection (20LFM) or forced air convection					
Note:						
①The Ctrl pin voltage is referenced to input -Vin.						
②For ripple and noise measuring method, please refer to Fig.1						

Electromagnetic Compatibility (EMC)

Emissions	CE	CISPR32/EN55032	CLASS A (see Fig.3 for recommended circuit)		
	RE	CISPR32/EN55032	CLASS A (see Fig.3 for recommended circuit)		
Immunity	ESD	IEC/EN61000-4-2	Contact ±6KV Air ±8KV	perf. Criteria A	
	RS	IEC/EN61000-4-3	20V/m	perf. Criteria A	
	EFT	IEC/EN61000-4-4	±2KV (see Fig.3 for recommended circuit)	perf. Criteria A	
	Surge	IEC/EN61000-4-5	differential mode ±1KV, 1.2/50us, source impedance 2Ω (see Fig.3 for recommended circuit)	perf. Criteria A	
	CS	IEC/EN61000-4-6	10Vr.m.s	perf. Criteria A	

Electromagnetic Compatibility (EMC)

Emissions	CE	EN50121-3-2 150kHz-500kHz 99dBuV (see Fig.3 for recommended circuit)	
		EN55016-2-1 500kHz-30MHz 93dBuV	
Immunity	RE	EN50121-3-2 30MHz-230MHz 40dBuV/m at 10m (see Fig.3 for recommended circuit)	
		EN55016-2-1 230MHz-1GHz 47dBuV/m at 10m	
	ESD	EN50121-3-2 Contact $\pm 6\text{kV}$ /Air $\pm 8\text{kV}$	perf. Criteria A
	RS	EN50121-3-2 20V/m	perf. Criteria A
	EFT	EN50121-3-2 $\pm 2\text{kV}$ 5/50ns 5kHz (see Fig.3 for recommended circuit)	perf. Criteria A
	Surge	EN50121-3-2 line to line $\pm 1\text{kV}$ (42 Ω , 0.5 μF) (see Fig.3 for recommended circuit)	perf. Criteria A
	CS	EN50121-3-2 0.15MHz-80MHz 10Vr.m.s	perf. Criteria A

Typical Performance Curves

DRWHB250-F1D05H Temperature Derating Curve

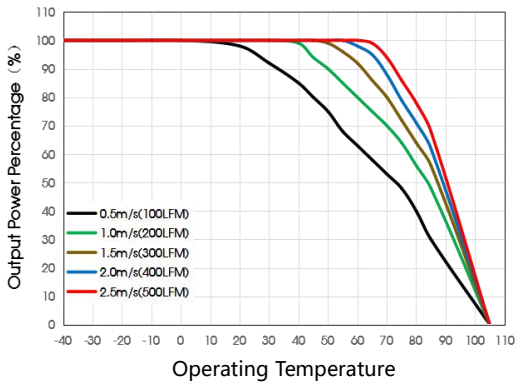

DRWHB250-F1D12H Temperature Derating Curve

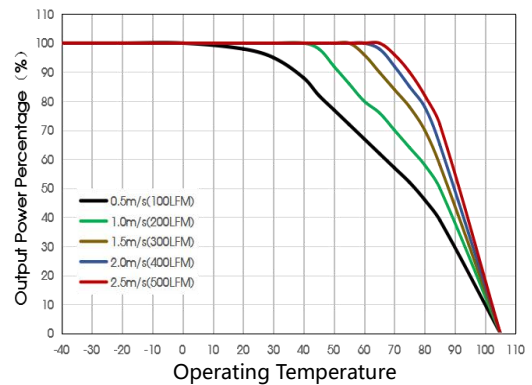

DRWHB250-F1D15H Temperature Derating Curve

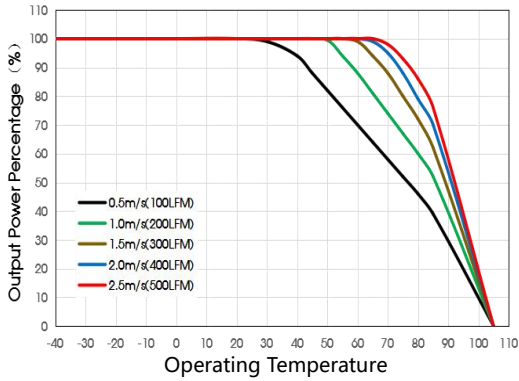

DRWHB250-F1D24H Temperature Derating Curve

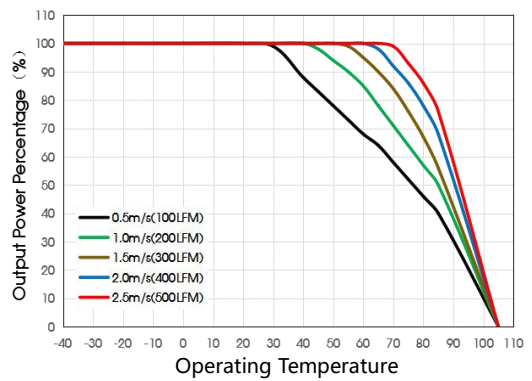

DRWHB250-F1D48H Temperature Derating Curve

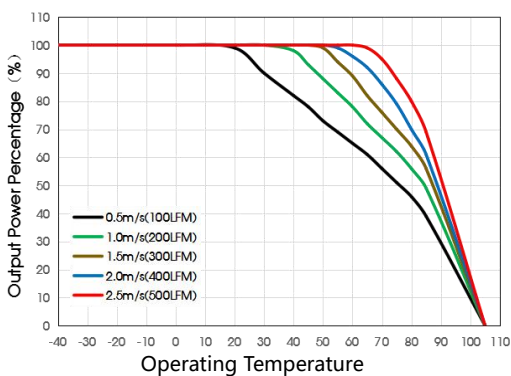

DRWHB250-F1D54H Temperature Derating Curve

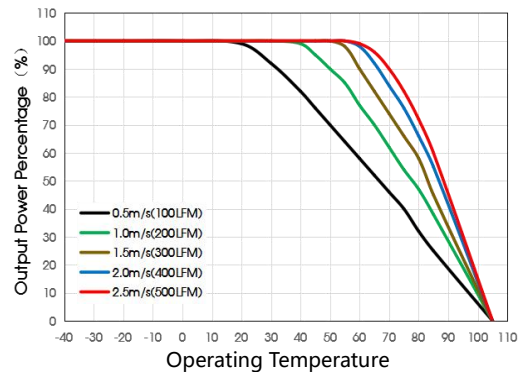

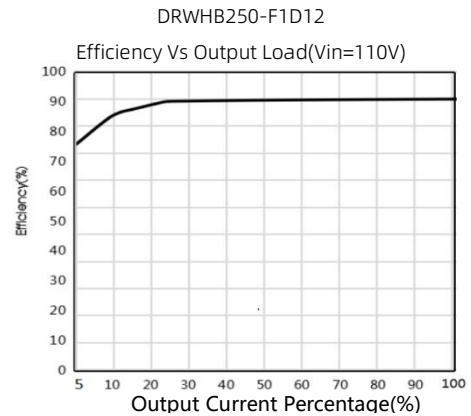
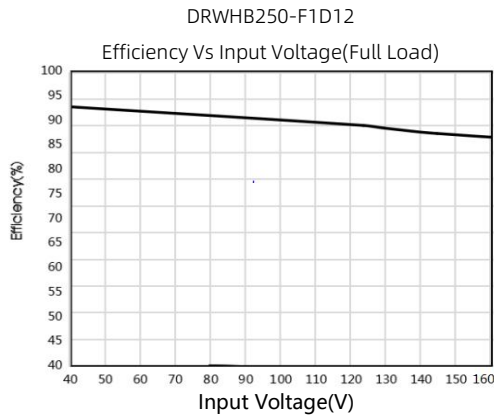

Remote Sense Application

1. Remote Sense Connection if not used

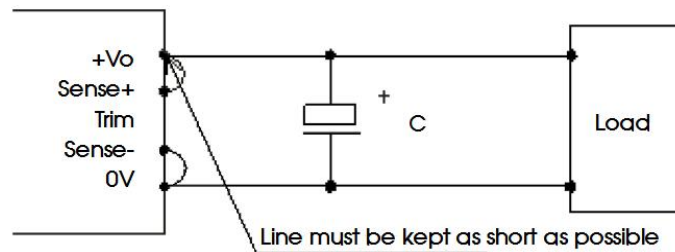

Notes:

- 1.If the sense function is not used for remote regulation the user must connect the +Sense to +Vo and -Sense to 0V at the DC-DC converter pins and will compensate for voltage drop across pins only.
2. The connections between Sense lines and their respective power lines must be kept as short as possible, otherwise they may be picking up noise, interference and/or causing unstable operation of the power module.

2. Remote Sense Connection used for Compensation

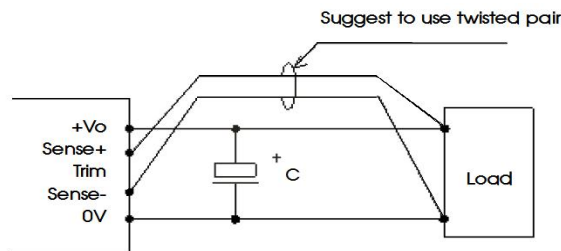

Notes:

- 1.Using remote sense with long wires may cause unstable output, please contact technical support if long wires must be used.
- 2.PCB-tracks or cables/wires for Remote Sense must be kept as short as possible. Twisted pair or shielded wires are suggested for remote compensation and must be kept as short as possible.
- 3.We recommend using adequate cross section for PCB-track layout and/or cables to connect the power supply module to the load in order to keep the voltage drop below 0.3V and to make sure the power supply's output voltage remains within the specified range.
- 4.Note that large wire impedance may cause oscillation of the output voltage and/or increased ripple. Consult technical support or factory for further advice of sense operation.

Design Reference

1. Ripple & noise

All the DC-DC converters of this series are tested before delivery using the recommended circuit shown in Fig. 1.

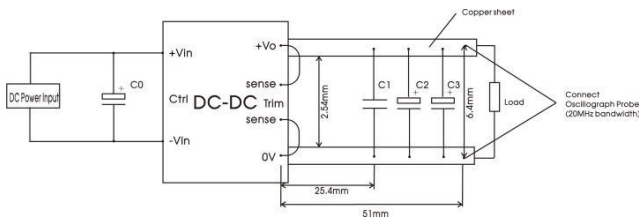

Fig.1

Capacitors Output voltage	C0	C1	C2	C3
5VDC	100μF aluminum Electrolytic capacitor (Voltage≥ 200V)	105K/50V ceramic capacitor	10μF/35V tantalum capacitor	220μF/35V electrolytic capacitor
12VDC				
15VDC				
24VDC				
40VDC				
48VDC	105K/100 V ceramic capacitor	--	220μF/100V electrolytic capacitor	
54VDC				

Notes: The mounting of E5 no needs C0.

2. Typical application

We recommended using EMC circuit, otherwise please ensure that at least a 100μF electrolytic capacitors is connected at the input in order to ensure adequate voltage surge suppression and protection.

Input and/or output ripple can be further reduced by appropriately increasing the input & output capacitor values C_{in} and C_{out} and/or by selecting capacitors with a low ESR (equivalent series resistance). Also make sure that the capacitance is not exceeding the specified max. capacitive load value of the product.



Fig.2

Capacitor Value	Cout	Cin
Output Voltage		
5V/12V/15V/24V/40V/48V/54V	220μF/63V	100 μF/200V

Notes: The mounting of E5 no needs Cin.

3. EMC solution-recommended circuit

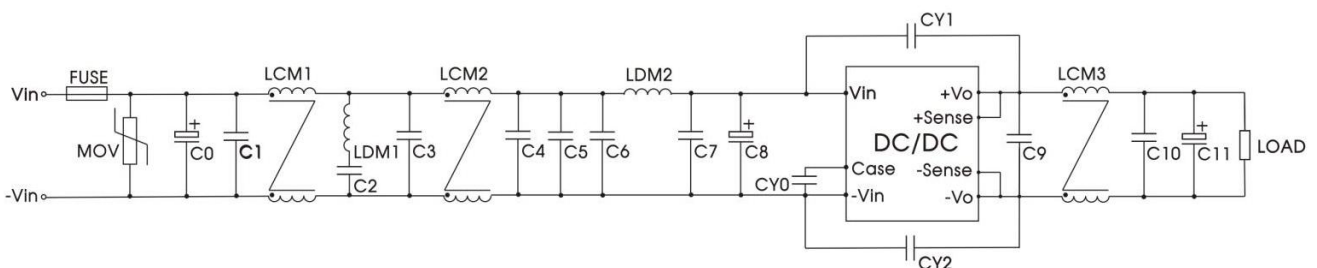
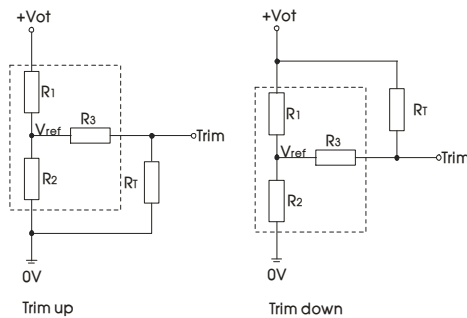

Fig. 3

Components	Recommended Component value
FUSE	Choose according to actual input current
MOV	S20K130 (Varistor)
C0	150μF/200V electrolytic capacitor
C8	100μF/200V electrolytic capacitor
C11	220μF/63V electrolytic capacitor
C1/ C2/ C3/ C4/ C5/ C6/ C7/C9/ C10	2.2μF/ 250V ceramic capacitor
LCM1	4000μH*2, 6A
LCM2	450μH*2, 6A
LCM3	4μH*2, 40A
LDM1	0.47uH Shielded inductor
LDM2	2.2uH Shielded inductor
CY0	1nF/400VAC Y1 safety capacitor
CY1	2.2nF/400VAC Y1 safety capacitor
CY2	1nF/400VAC Y1 safety capacitor

4. Trim Function for Output Voltage Adjustment (open if unused)



TRIM resistor connection (dashed line shows internal resistor network)

Calculation formula of Trim resistance:

$$\begin{aligned} \text{up: } R_T &= \frac{\alpha R_2}{R_2 - \alpha} - R_3 & \alpha &= \frac{V_{ref}}{V_o' - V_{ref}} \cdot R_1 \\ \text{down: } R_T &= \frac{\alpha R_1}{R_1 - \alpha} - R_3 & \alpha &= \frac{V_o' - V_{ref}}{V_{ref}} \cdot R_2 \end{aligned}$$

Note: Value for R1, R2, R3, and V_{ref} refer to the above table 1.

R_T : Resistance of Trim.

α : User-defined parameter, no actual meanings.

V_o' : The trim up/down voltage.

Table 1

Vo Res	5 (VDC)	12 (VDC)	15 (VDC)	24 (VDC)	40 (VDC)	48 (VDC)	54 (VDC)
R1(KΩ)	2.92	11	14.49	24.87	48.37	58.69	60.44
R2(KΩ)	2.87	2.87	2.87	2.87	3.21	3.21	2.91
R3(KΩ)	12	17.8	20	20	20	20	17.8
Vref(V)	2.495	2.495	2.495	2.495	2.495	2.495	2.495

5. The products do not support parallel connection of their output

DRWHB250-F1Dxx Dimensions and Recommended Layout

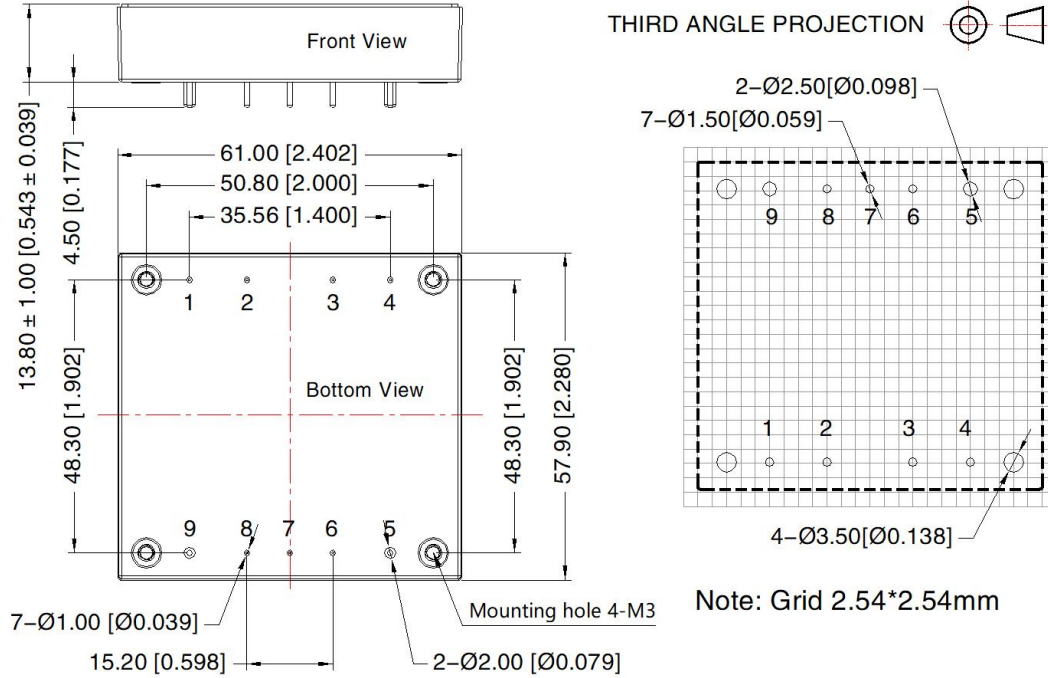

Note:

Unit: mm[inch]

Pin1,2,3,4,6,7,8's diameter: 1.00[0.039]

Pin5,9's diameter: 2.00[0.079]

Pin diameter tolerances: $\pm 0.10[\pm 0.004]$

General tolerances: $\pm 0.50[\pm 0.020]$

Mounting hole screwing torque: Max 0.4 N·m

Pin-Out			
Pin	Function	Pin	Mark
1	+Vin	6	Sense-
2	Ctrl	7	Trim
3	Case	8	Sense+
4	-Vin	9	+Vo
5	0V		

DRWHB250-F1DxxH Dimensions and Recommended Layout

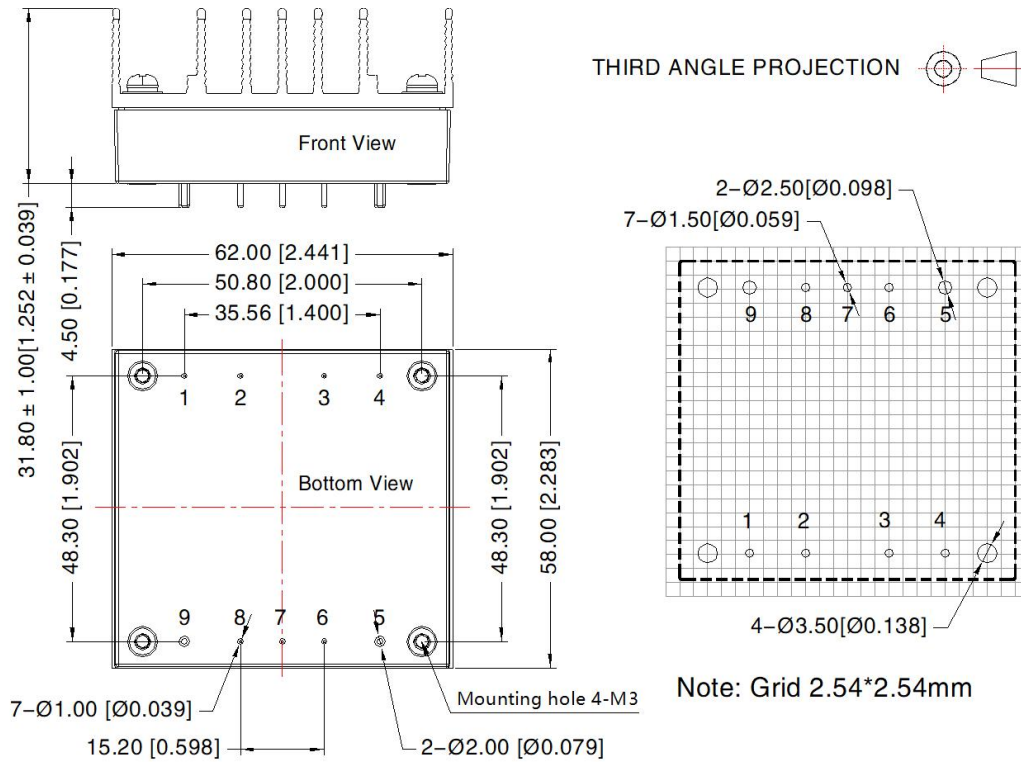

Note:
 Unit: mm[inch]
 Pin1,2,3,4,6,7,8's diameter: 1.00[0.039]
 Pin5,9's diameter: 2.00[0.079]
 Pin diameter tolerances: $\pm 0.10[\pm 0.004]$
 General tolerances: $\pm 0.50[\pm 0.020]$
 Mounting hole screwing torque: Max 0.4 N·m

Pin-Out			
Pin	Function	Pin	Mark
1	+Vin	6	Sense-
2	Ctrl	7	Trim
3	Case	8	Sense+
4	-Vin	9	+Vo
5	0V		

DRWHB250-F1D05/12/15E5 Dimensions and Recommended Layout

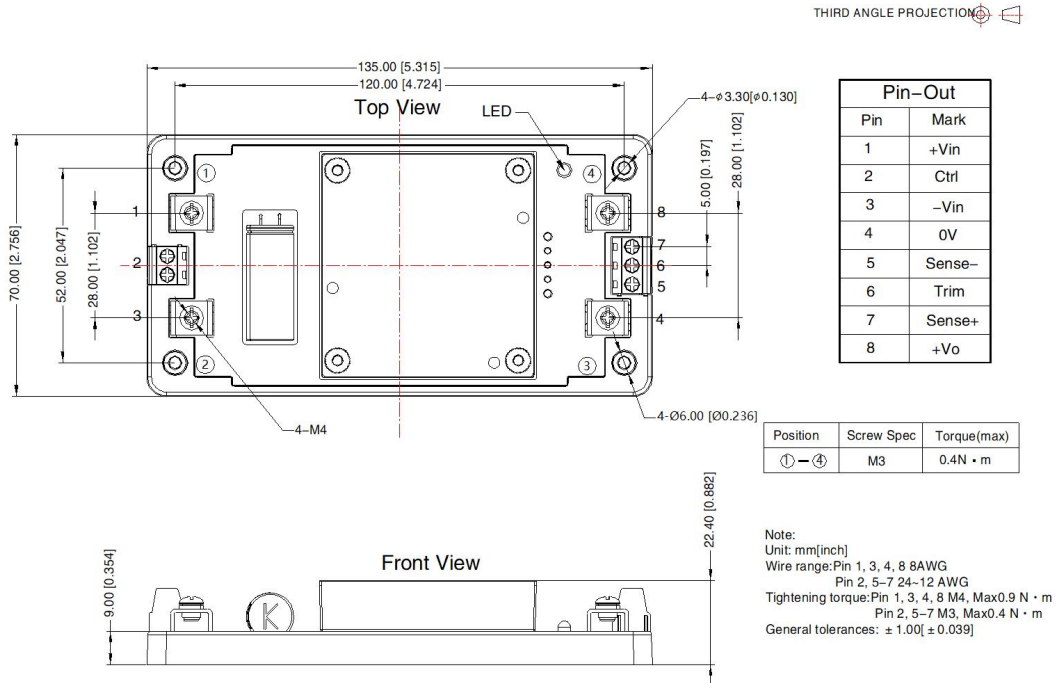

DRWHB250-F1D24/48/54E5 Dimensions and Recommended Layout

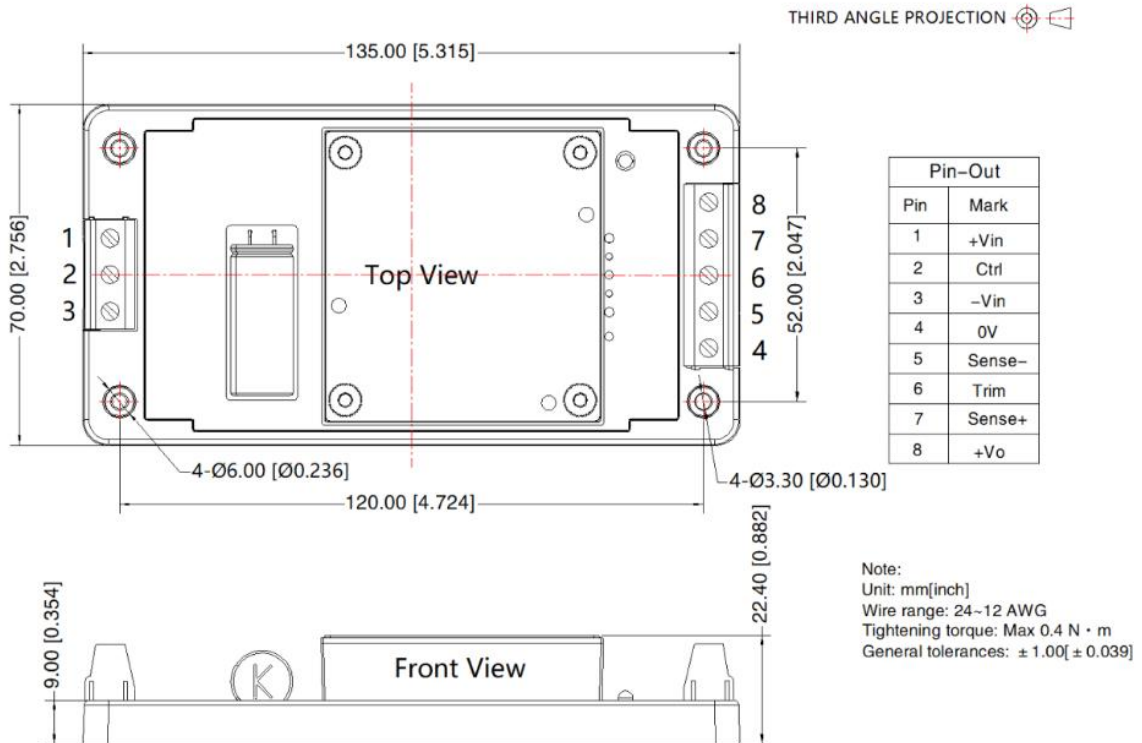

DRWHB250-F1D05/12/15HE5 Dimensions and Recommended Layout

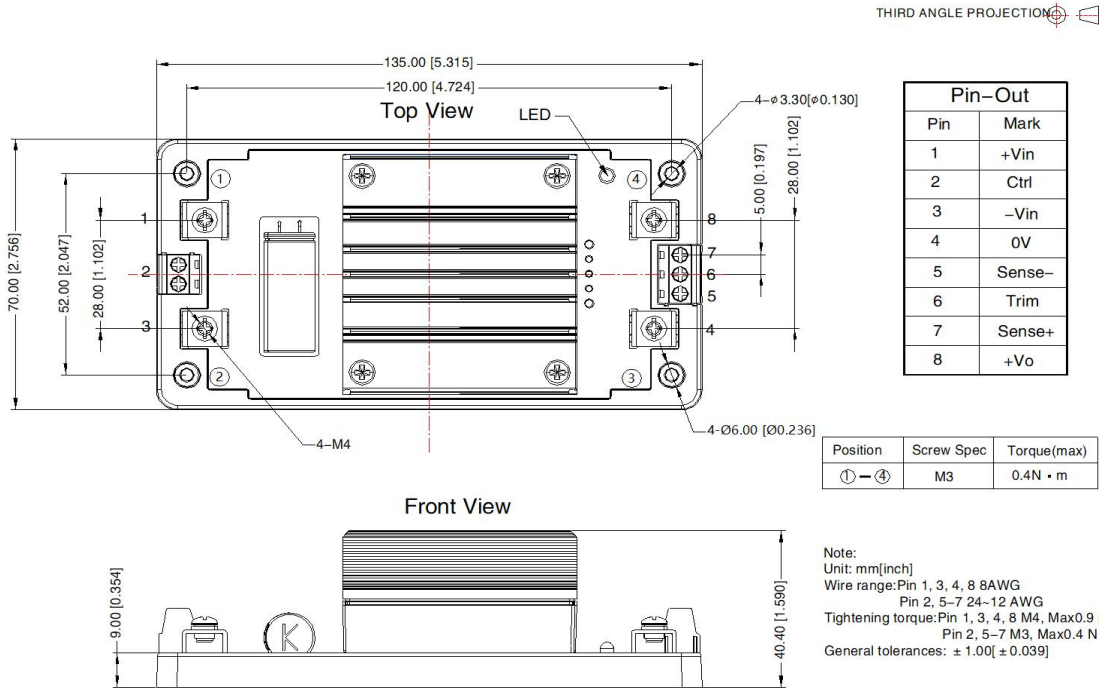

DRWHB250-F1D24/48/54HE5 Dimensions and Recommended Layout

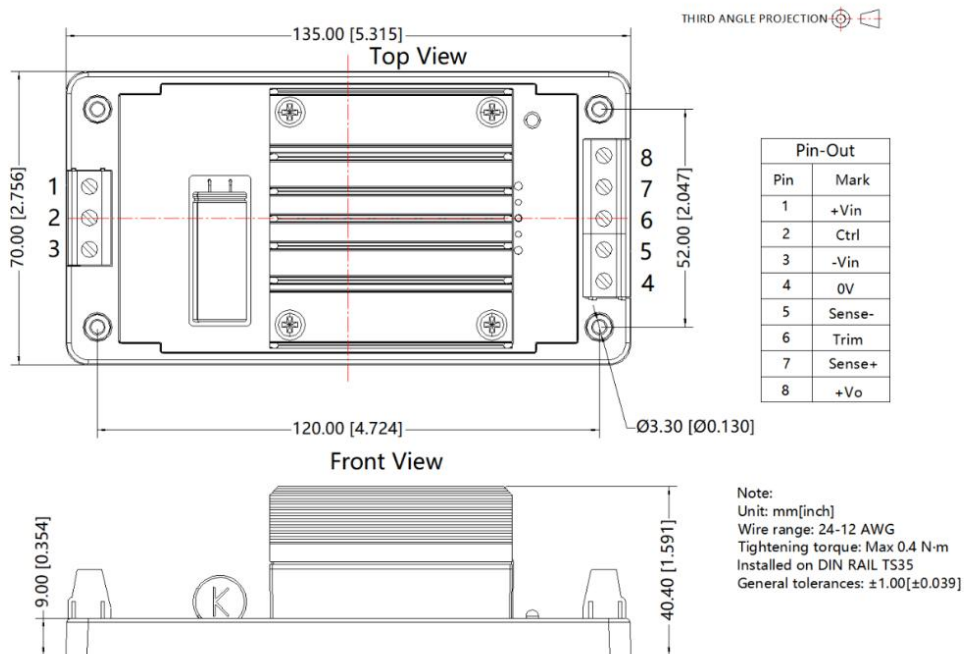

Note:

1. We suggest to use module at load of over 5%, if not, the ripple of the product may exceeds the specification, but does not affect the reliability of the product;
2. It is recommended that the load imbalance of the dual output is $\leq \pm 5\%$. If it exceeds $\pm 5\%$, the performance of the product cannot be guaranteed to meet as datasheet marked. For details, please contact our technical staff;
3. The maximum capacitive load offered were tested at input voltage range and full load;
4. Unless otherwise specified, parameters in this datasheet were measured under the conditions of $T_a=25^\circ\text{C}$, humidity $<75\%$ RH with nominal input voltage and rated output load;
5. All index testing methods in this datasheet are based on company corporate standards;
6. We can provide product customization service, please contact our technicians directly for specific information;
7. Products are related to laws and regulations: see "Features" and "EMC";
8. Our products shall be classified according to ISO14001 and related environmental laws and regulations, and shall be handled by qualified units.