

Descriptions 20W isolated, DC/DC Converter



EN62368-1 BS EN62368-1

Features

- Ultra-wide 4:1 input voltage range
- Reinforced I/O isolation test voltage 2.25k VDC
- Operating ambient temperature range -40°C to +85°C
- Input under-voltage protection, output short circuit, over-current, over-voltage protection
- Low output ripple & noise
- EN50121-3-2 & CISPR32/EN55032 CLASS A EMI compliant without external components
- Designed to meet EN50155/EN62368 safety standards
- Designed to meet IEC62368/UL62368 safety standards
- Input Reverse Polarity Protection available with Chassis (E2S) or 35mm DIN-Rail mounting (D4S) version
- Industry standard pin-out

Applications

- Railway vehicle applications using 72V, 96V and 110V battery voltages

Selection Guide

Certification	Part No. ^①	Input Voltage (VDC)		Output		Full Load Efficiency ^③ (%) Min./Typ.	Max. Capacitive Load(μF)
		Nominal (Range)	Max. ^②	Voltage (VDC)	Current(mA) Max./Min.		
EN/BS EN	DRWLD20-B1D03	110 (40-160)	170	3.3	5000/0	80/82	10000
	DRWLD20-B1D05			5	4000/0	83/85	10000
	DRWLD20-B1D12			12	1667/0	84/86	1600
	DRWLD20-B1D15			15	1333/0	84/86	1000
	DRWLD20-B1D24			24	833/0	85/87	470

Note:
 ① Use "H" suffix for heat sink mounting, "E2S" suffix for chassis mounting and "D4S" suffix for DIN-Rail mounting. We recommend to choose modules with a heat sink for enhanced heat dissipation and applications with extreme temperature requirements;
 ② Absolute maximum stress rating without damage (not recommended);
 ③ Efficiency is measured at nominal input voltage and rated output load; efficiencies for E2S and D4S Model's is decreased by 2% due to the input reverse polarity protection circuit.

Specifications

Product Specifications	Item	Operating Conditions	Min.	Typ.	Max.	Unit		
Input Specifications	Input Current (full load / no-load)	Nominal input voltage	3.3V output	--	183/10	188/20	mA	
			5V output	--	214/10	219/20		
			Others	--	212/3	217/8		
	Reflected Ripple Current	Nominal input voltage		--	25	--	VDC	
	Surge Voltage (1sec. max.)			-0.7	--	180		
	Start-up Voltage	100% load		--	--	40		
	Shut-down Voltage			28	33	--		
	Start-up Time	Nominal input voltage & constant resistance load		--	10	--	ms	
	Input Filter			Pi filter				
	Hot Plug			Unavailable				
Ctrl [Ⓞ]	Module on		Ctrl pin open or pulled high (3.5-12VDC)					
	Module off		Ctrl pin pulled low to GND (0-1.2VDC)					
	Input current when off		--	2	7	mA		
Output Specifications	Voltage Accuracy	0% -100% load		--	±1	±3	%	
	Linear Regulation	Input voltage variation from low to high at full load		--	±0.2	±0.5		
	Load Regulation	0% -100% load		--	±0.5	±1		
	Transient Recovery Time	25% load step change, nominal input voltage			--	300	500	μs
	Transient Response Deviation		3.3V/5V output		--	±3	±8	%
		Others		--	±3	±5		
	Temperature Coefficient	Full load		--	±0.02	±0.03	%/°C	
	Ripple & Noise [Ⓜ]	20MHz bandwidth, 5% -100% load		--	50	100	mV p-p	
	Trim			90	--	110	%Vo	
	Over-voltage Protection			110	--	160		
	Over-current Protection	Input voltage range		120	--	210		%Io
Short-circuit Protection			Continuous, self-recovery					
General Specifications	Isolation	Input-output Electric Strength Test for 1 minute with a leakage current of 1mA max.		2250	--	--	VDC	
		Input/output-case Electric Strength Test for 1 minute with a leakage current of 1mA max.		1600	--	--		
	Insulation Resistance	Input-output resistance at 500VDC		1000	--	--	MΩ	
	Isolation Capacitance	Input-output capacitance at 100KHz/0.1V		--	2200	--	pF	
	Operating Temperature	See Fig. 1		-40	--	+85	°C	
	Storage Temperature			-55	--	+125		
	Storage Humidity	Non-condensing		5	--	95	%RH	
Pin Soldering Resistance Temperature	Soldering spot is 1.5mm away from case for 10 seconds		--	--	300	°C		

	Switching Frequency ^③	PWM mode	--	300	--	KHz
	Vibration		IEC61373 - Category 1, Grade B			
	MTBF	MIL-HDBK-217F@25°C	1000	--	--	K hours
Mechanical Specifications	Case Material	Aluminum alloy				
	Dimensions	Without heat sink	Horizontal package	50.80 × 25.40 × 11.80 mm		
			E2S chassis mounting	76.00 × 31.50 × 21.20 mm		
			D4S Din-rail mounting	76.00 × 31.50 × 25.80 mm		
		With heat sink	Horizontal package	51.40 × 26.20 × 16.50 mm		
			E2S chassis mounting	76.00 × 31.50 × 25.30 mm		
			D4S Din-rail mounting	76.00 × 31.50 × 29.90 mm		
Weight	Without heat sink	Horizontal package/E2S chassis mounting/D4S Din-rail mounting	26.0g/48.0g/68.0g (Typ.)			
	With heat sink	Horizontal package/E2S chassis mounting/D4S Din-rail mounting	34.0g/56.0g/76.0g (Typ.)			
Cooling Method	Free air convection					

Note:

① The Ctrl pin voltage is referenced to input GND;

② Ripple & Noise at < 5% load is 5%Vo max. The "parallel cable" method is used for Ripple and Noise test, please refer to DC-DC Converter Application Notes for specific information;

③ Switching frequency is measured at full load. The module reduces the switching frequency for light load (below 50%) efficiency improvement.

Electromagnetic compatibility (EMC) (EN62368)

Emissions	CE	CISPR32/EN55032	CLASS A (without external components)/CLASS B (see Fig. 4-② for recommended circuit)	
	RE	CISPR32/EN55032	CLASS A (without external components)/CLASS B (see Fig. 4-② for recommended circuit)	
Immunity	ESD	IEC/EN61000-4-2	Contact ±6KV/Air ±8KV perf. Criteria B	
	RS	IEC/EN61000-4-3	10V/m perf. Criteria A	
	EFT	IEC/EN61000-4-4	±4KV (see Fig.3 or Fig.4-① for recommended circuit) perf. Criteria B	
	Surge	IEC/EN61000-4-5	line to line ±2KV (2Ω 0.5uF see Fig.3 for recommended circuit) line to ground ±4KV (12Ω 0.5uF see Fig.3 for recommended circuit)	perf. Criteria B
		EN50121-3-2	line to line ±1KV (42Ω 0.5uF see Fig.4-① for recommended circuit) line to ground ±2KV (42Ω 0.5uF see Fig.4-① for recommended circuit)	perf. Criteria B
CS	IEC/EN61000-4-6	10 Vr.m.s	perf. Criteria A	

Electromagnetic Compatibility (EMC) (EN50155)

Emissions	CE	EN50121-3-2	150kHz-500kHz 99dBuV
		EN55016-2-1	500kHz-30MHz 93dBuV
	RE	EN50121-3-2	30MHz-230MHz 40dBuV/m at 10m
		EN55016-2-1	230MHz-1GHz 47dBuV/m at 10m
Immunity	ESD	EN50121-3-2	Contact ±6KV/Air ±8KV perf. Criteria B

RS	EN50121-3-2	20V/m	perf. Criteria A
EFT	EN50121-3-2	±2kV 5/50ns 5kHz	perf. Criteria A
Surge	EN50121-3-2	line to line ±1KV (42Ω, 0.5μF) line to ground ±2KV (42Ω, 0.5μF)	perf. Criteria B
CS	EN50121-3-2	0.15MHz-80MHz 10V r.m.s	perf. Criteria A

Note: All the tests are measured under the conditions of inputs capacitor 100uF/200V .

Typical Characteristic Curves

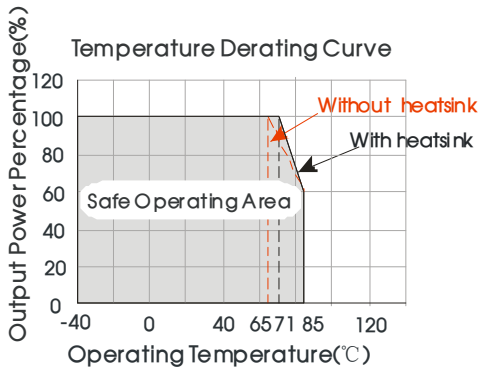

Operating Temperature, Except DRWLD20-B1D03/05(H)(E2S/D4S)

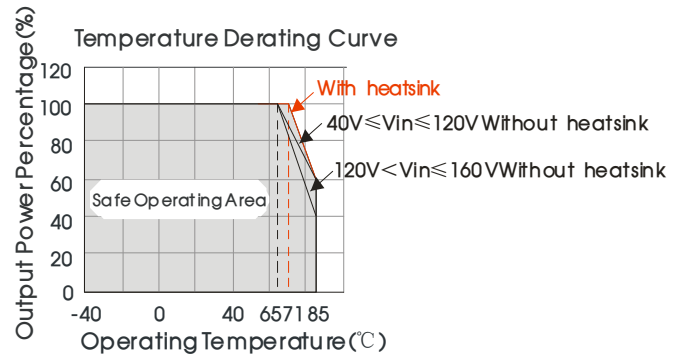

DRWLD20-B1D03(H)(E2S/D4S) Operating Temperature

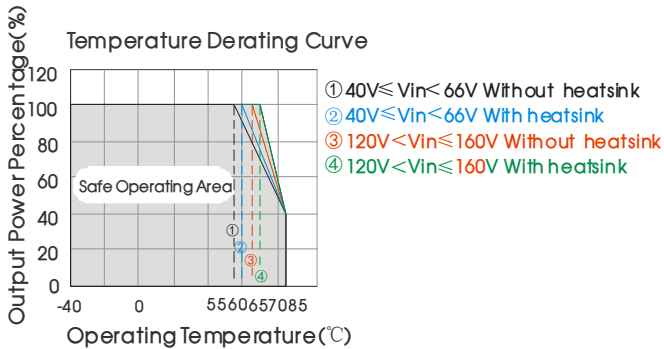

DRWLD20-B1D05(H)(E2S/D4S) Operating Temperature

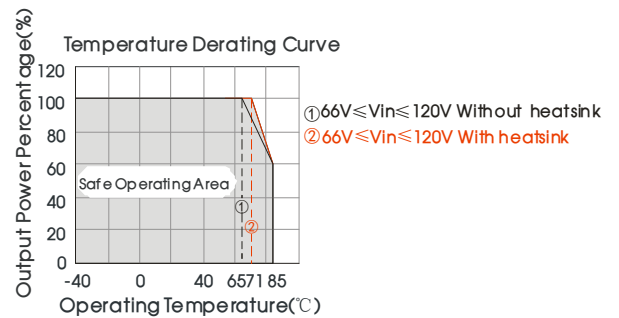
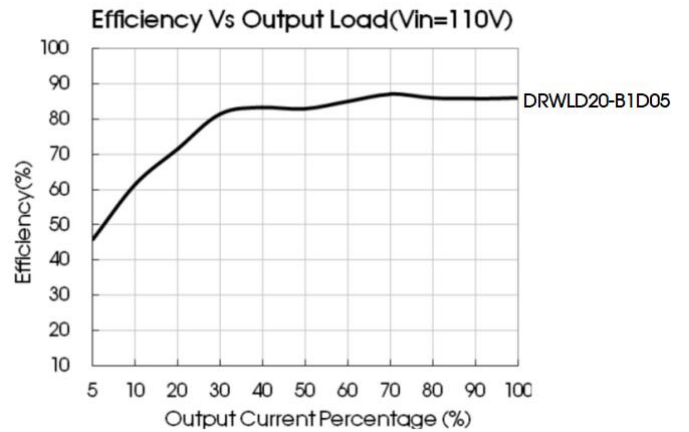
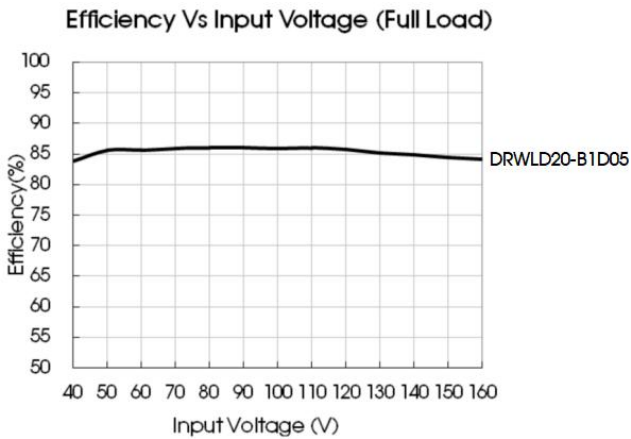
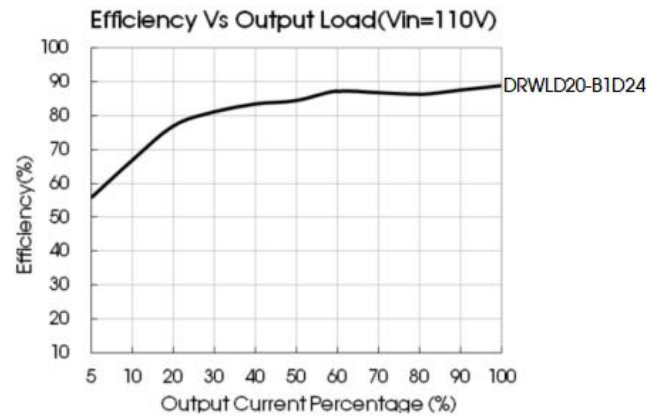
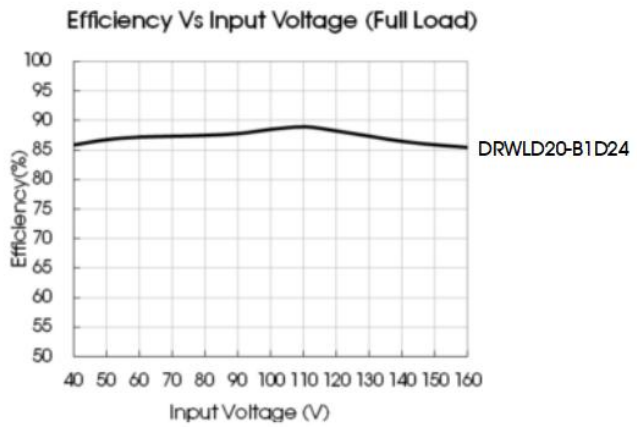

Fig. 1





Design Reference

1. Typical application

All DC-DC converters of this series are tested before delivery using the recommended circuit shown in Fig. 2.

Input and/or output ripple can be further reduced by appropriately increasing the input & output capacitor values C_{in} and C_{out} and/or by selecting capacitors with a low ESR (equivalent series resistance). Also make sure that the capacitance is not exceeding the max. capacitive load value of the product.



Fig. 2

Vout(VDC)	Fuse	Cin	Cout
3.3/5	2A, slow blow	10 μ F - 47 μ F	470 μ F
12/15			220 μ F
24			100 μ F

2. EMC compliance circuit

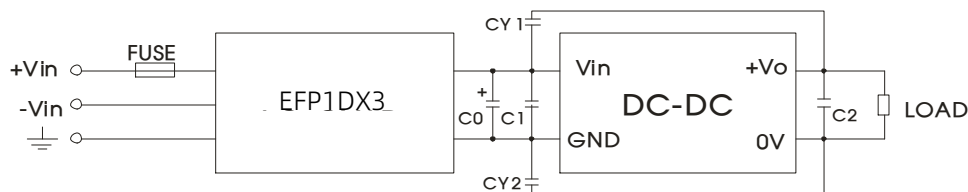

Fig. 3

Fig.3 List of components:

Output voltage	3.3V	5V	12V	15V	24V
FUSE	Choose according to actual input current				
Filter	The filter is the EMC auxiliary component of our company. Input voltage range: 40V-160V				
C0	100 μ F/200V				
C1	47 μ F/200V				
C2	470 μ F/16V		220 μ F/25V		100 μ F/35V
CY1, CY2	1000pF/400VAC				

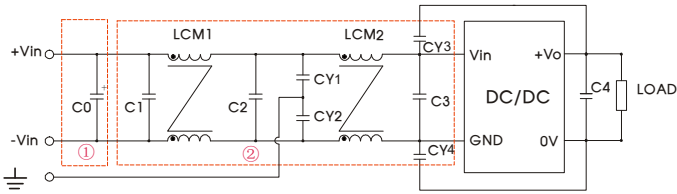

Fig. 4

Notes: Part ① in the Fig. 4 is used for EMS test and part ② for EMI test

Fig.4 List of components:

Output voltage	3.3V	5V	12V	15V	24V
C0	100μF/200V				
C1、C2	0.22μF/250V				
C3	47μF/200V				
LCM1、LCM2	15mH (UU common mode inductance)				
CY1、CY2、CY3、CY4	1000pF/400VAC				
C4	470μF/16V	220μF/25V	100μF/35V		

3. Trim Function for Output Voltage Adjustment (open if unused)

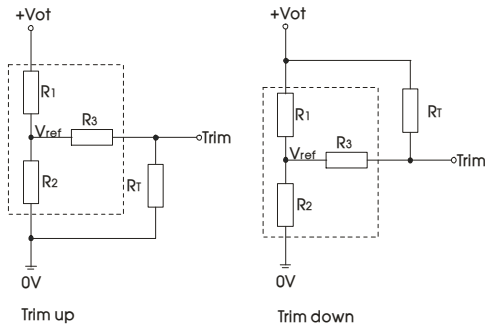

Calculating Trim resistor values:

$$\begin{aligned} \text{up: } R_T &= \frac{\alpha R_2}{R_2 - \alpha} - R_3 & \alpha &= \frac{V_{ref}}{V_o' - V_{ref}} \cdot R_1 \\ \text{down: } R_T &= \frac{\alpha R_1}{R_1 - \alpha} - R_3 & \alpha &= \frac{V_o' - V_{ref}}{V_{ref}} \cdot R_2 \end{aligned}$$

TRIM resistor connection (dashed line shows internal resistor network)

R_T = Trim Resistor value; α = self-defined parameter; V_o' = desired output voltage

Vout(V)	R1(KΩ)	R2(KΩ)	R3(KΩ)	Vref(V)
3.3	4.801	2.87	10	1.24
5	2.883	2.87	10	2.5
12	11.000	2.87	15	2.5
15	14.384	2.87	15	2.5
24	24.872	2.87	17.8	2.5

4. The products do not support parallel connection of their output

Horizontal Package (without heat sink) Dimensions and Recommended Layout

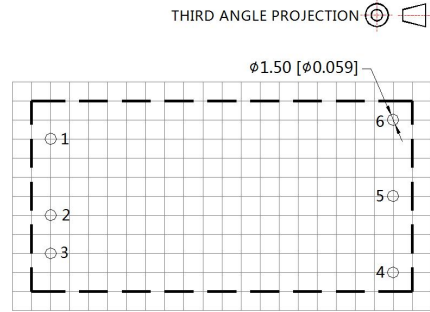
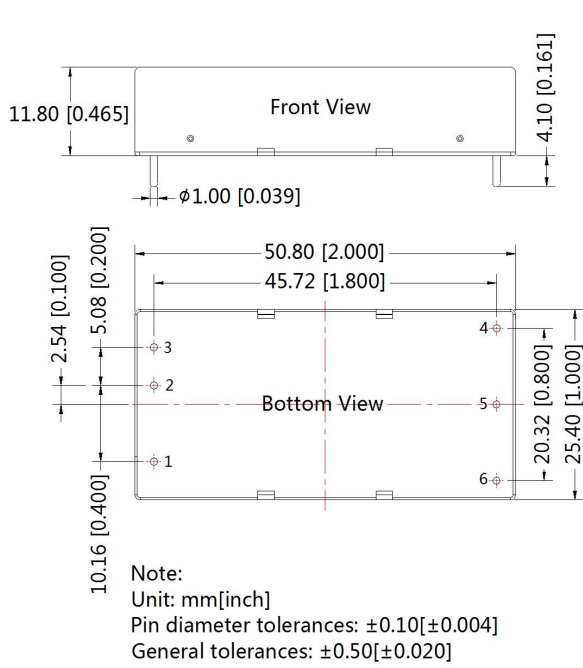

Note : Grid 2.54*2.54mm

Pin-Out	
Pin	Function
1	Ctrl
2	GND
3	Vin
4	+Vo
5	0V
6	Trim

Horizontal Package (with heat sink) Dimensions

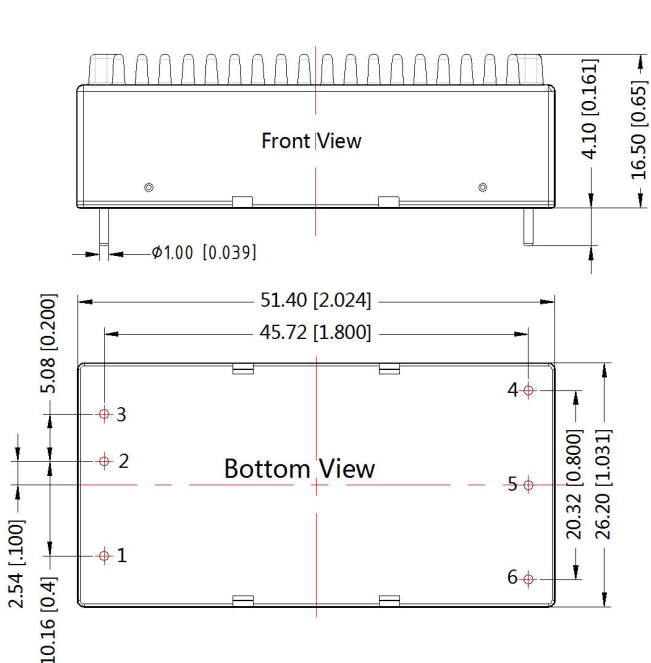

THIRD ANGLE PROJECTION

Pin-Out	
Pin	Function
1	Ctrl
2	GND
3	Vin
4	+Vo
5	0V
6	Trim

Note:
Unit: mm[inch]
General tolerances: $\pm 0.50[\pm 0.020]$

DRWLD20-B1DxxE2S (without heat sink) Dimensions

THIRD ANGLE PROJECTION

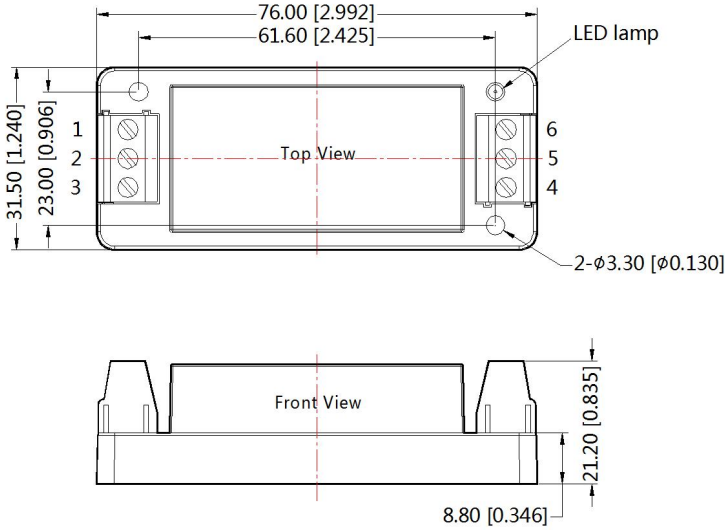

Pin-Out						
Pin	1	2	3	4	5	6
Function	Ctrl	GND	Vin	+Vo	0V	Trim

Note:
 Unit: mm[inch]
 Wire range: 24-12 AWG
 Tightening torque: Max 0.4 N·m
 General tolerances: $\pm 0.50[\pm 0.020]$

DRWLD20-B1DxxHE2S (with heat sink) Dimensions

THIRD ANGLE PROJECTION

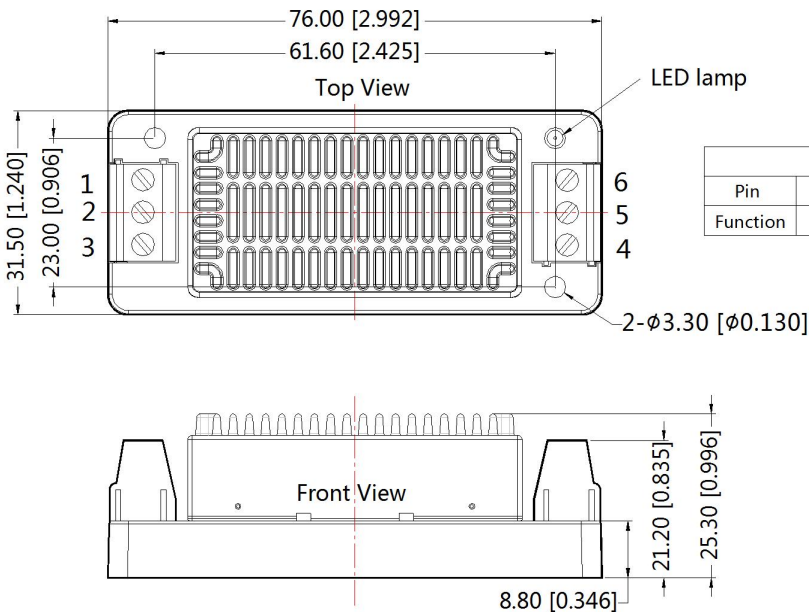

Pin-Out						
Pin	1	2	3	4	5	6
Function	Ctrl	GND	Vin	+Vo	0V	Trim

Note:
 Unit: mm[inch]
 Wire range: 24-12 AWG
 Tightening torque: Max 0.4 N·m
 General tolerances: $\pm 1.00[\pm 0.039]$

DRWLD20-B1DxxD4S (without heat sink) Dimensions

THIRD ANGLE PROJECTION

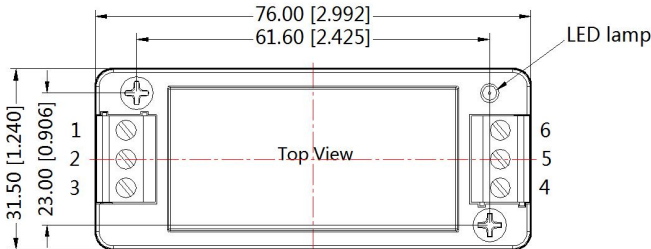

Pin-Out						
Pin	1	2	3	4	5	6
Function	Ctrl	GND	Vin	+Vo	0V	Trim

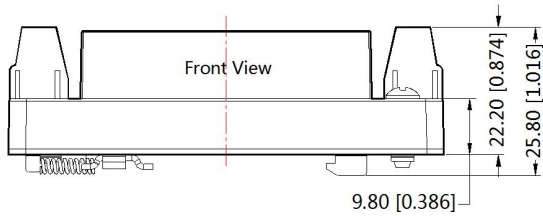

Note:
 Unit: mm[inch]
 Mounting rail: TS35
 Wire range: 24-12 AWG
 Tightening torque: Max 0.4 N·m
 General tolerances: $\pm 1.00[\pm 0.039]$

DRWLD20-B1DxxHD4S (with heat sink) Dimensions

THIRD ANGLE PROJECTION

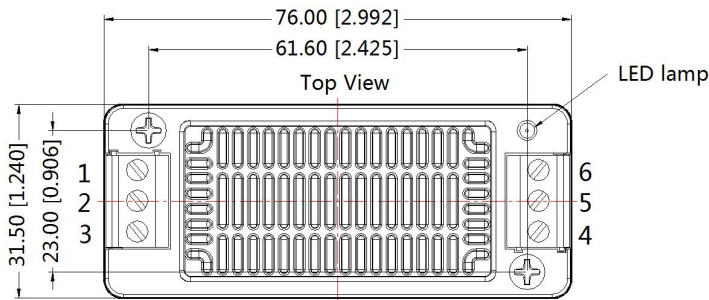

Pin-Out						
Pin	1	2	3	4	5	6
Function	Ctrl	GND	Vin	+Vo	0V	Trim

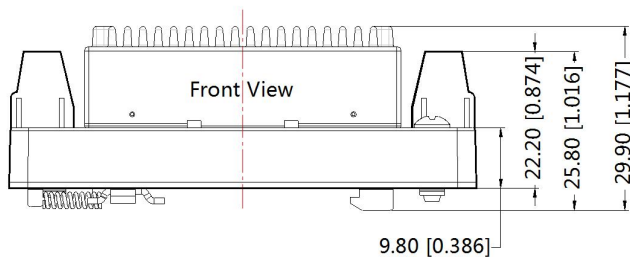

Note:
 Unit: mm[inch]
 Mounting rail: TS35
 Wire range: 24-12 AWG
 Tightening torque: Max 0.4 N·m
 General tolerances: $\pm 1.00[\pm 0.039]$

Note:

1. The maximum capacitive load offered were tested at input voltage range and full load;
2. Unless otherwise specified, parameters in this datasheet were measured under the conditions of $T_a=25^{\circ}\text{C}$, humidity<75%RH with nominal input voltage and rated output load;
3. All index testing methods in this datasheet are based on Company's corporate standards;
4. We can provide product customization service, please contact our technicians directly for specific information;
5. Products are related to laws and regulations: see "Features" and "EMC";
6. Our products shall be classified according to ISO14001 and related environmental laws and regulations, and shall be handled by qualified units.