

RoHS10 Support

REACH Support

CFSI Support

IP66 Waterproof after mating (Requires waterproof tube)

○形状 (SHAPE)

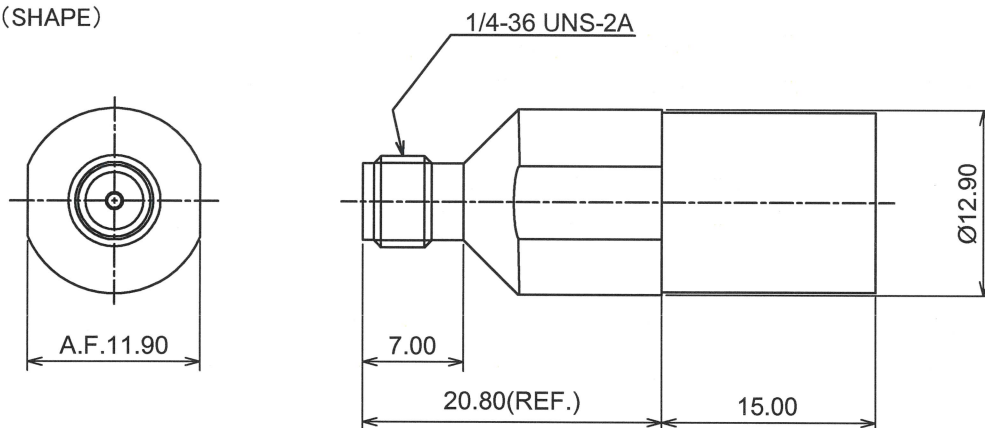

○規格 (STANDARD)

MIL-C-39012

○仕様 (SPECIFICATION)

- 特性インピーダンス (Impedance) : 50 Ω
- 定格周波数 (Working Frequency Range) : DC~6GHz
- 電圧定在波比 (VSWR) : ≤ 1.50 max at 6GHz
- 挿入損失 (Insertion Loss) : 0.04dB max × √f GHz (f:Frequency)
- 定格電圧 (Voltage Rating) : 335 Vrms max
- 耐電圧 (Proof Voltage) : 1000 Vrms max
- 勘合保証回数 (Connector Life) : 500 times min
- 使用温度範囲 (Temperature range) : -50°C~150°C
- 推奨締め付けトルク (Recommended Torque) 0.8~1.1 Nm

○加工寸法 (ASSEMBLY)

RECOMMENDED CABLE STRIPPING DIMS

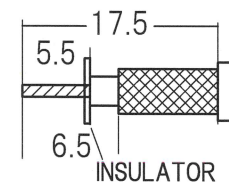

- IF THE CORE WIRE IS A STRANDED WIRE, PERFORM PRELIMINARY SOLDERING.
- INSERT INSULATION INTO THE CABLE
- PUSH THE CABLE CENTER CONDUCTOR

RECOMMENDED CLIPPING TOOL SIZE

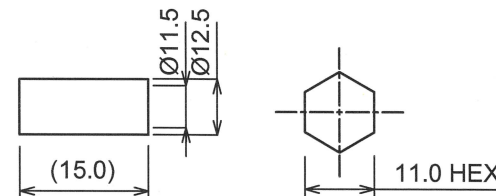

RECOMMENDED CRIMP HEIGHT 11.00±0.30

The tolerance in this area is ± 0.10

5	FERRULE	BRASS	NICKEL
4	INSULATOR	PTFE	NONE
3	Contact	BeCu	GOLD
2	Dielectric	PTFE	NONE
1	Body	BRASS	NICKEL
No	DESCRIPTION	MATERIAL	FINISH



TOLERANCE				日本エレパーツ株式会社 NIHON ELEPARTS Co.,LTD	
DECIMALS	.XX ±0.08	.X ±0.13			
DIAMETER	.X ±0.03			N A M E	SMA-PS-RG9AU
Approved	Checked	Drawn	Unit		
			mm		
			A4		2