

DC ギャードモータ DC GEARED MOTORS

LC22G

RoHS 指令対応 RoHS compliant



LC22G-103
LC22G-105

Weight : approx. 60 g
(ギヤ比 1/10 Gear ratio 1/10)



LC22G-107
LC22G-108

Weight : approx. 110 g
(ギヤ比 1/10 Gear ratio 1/10)

型式表示 PART NUMBER DESIGNATION

LC22G-103 1/10

シリーズ名 Series name

LC22G-103 : DC 24 V
LC22G-105 : DC 12 V
LC22G-107 : DC 24 V
LC22G-108 : DC 12 V

ギヤ比 Gear ratio

1/10 1/150
1/25 1/300
1/30 1/500
1/50 1/1000
1/100 1/1500

型式一覧表 LIST OF PART NUMBERS

ギヤ比 Gear ratio	型式 Part number	型式 Part number
1/10	LC22G-103 1/10	LC22G-105 1/10
1/25	LC22G-103 1/25	LC22G-105 1/25
1/50	LC22G-103 1/50	LC22G-105 1/50
1/100	LC22G-103 1/100	LC22G-105 1/100
1/150	LC22G-103 1/150	LC22G-105 1/150
1/300	LC22G-103 1/300	LC22G-105 1/300
1/500	LC22G-103 1/500	LC22G-105 1/500
1/1000	LC22G-103 1/1000	☞ LC22G-105 1/1000
1/1500	☞ LC22G-103 1/1500	☞ LC22G-105 1/1500

ギヤ比 Gear ratio	型式 Part number	型式 Part number
1/10	LC22G-107 1/10	LC22G-108 1/10
1/30	LC22G-107 1/30	LC22G-108 1/30
1/50	LC22G-107 1/50	LC22G-108 1/50
1/100	LC22G-107 1/100	LC22G-108 1/100
1/150	LC22G-107 1/150	LC22G-108 1/150
1/300	LC22G-107 1/300	LC22G-108 1/300
1/500	LC22G-107 1/500	LC22G-108 1/500
1/1000	☞ LC22G-107 1/1000	☞ LC22G-108 1/1000
1/1500	☞ LC22G-107 1/1500	☞ LC22G-108 1/1500

※ ご注文に際しては、上記型式をご確認ください。

☞ 印の型式は受注生産となります。

※Verify the above part numbers when placing orders.

The products indicated by ☞ mark are manufactured upon receipt of order basis.

LC22G

DC GEARED MOTORS

標準仕様 STANDARD SPECIFICATIONS

<Motor only>

型式 Part number	定格電圧 Rated voltage	定格トルク Rated torque	定格回転数 Rated speed	定格電流 Rated current	無負荷回転数 No load speed	無負荷電流 No load current	起動トルク Starting torque	起動電流 Starting current
LC22G-103	24 V	1.96 mN·m	4900 min ⁻¹	80 mA	6100 min ⁻¹	25 mA	10.0 mN·m	350 mA
LC22G-105	12 V		5100 min ⁻¹	160 mA				
LC22G-107	24 V		7000 min ⁻¹	105 mA	8100 min ⁻¹	30 mA	14.42 mN·m	550 mA
LC22G-108	12 V		6100 min ⁻¹	180 mA	7300 min ⁻¹	60 mA	11.96 mN·m	600 mA

<With gearbox>

LC22G-103

減速比 Gear ratio	1/10	1/25	1/50	1/100	1/150	1/300	1/500	1/1000	1/1500
定格許容トルク Rated torque mN·m	4.9	7.8	9.8	14.7		24.5			
定格回転数 Rated speed min ⁻¹	578	234	121	60	40.5	20.9	12.4	6.1	4.1
定格電流 Rated current A	0.04		0.03						
無負荷回転数 No load speed min ⁻¹	610	244	122	61	41	21	12.5	6.1	4.1

LC22G-105

減速比 Gear ratio	1/10	1/25	1/50	1/100	1/150	1/300	1/500	1/1000	1/1500
定格許容トルク Rated torque mN·m	4.9	7.8	9.8	14.7		24.5			
定格回転数 Rated speed min ⁻¹	600	244	122	61	40.5	20.4	12.4	6.2	4.1
定格電流 Rated current A	0.06								
無負荷回転数 No load speed min ⁻¹	620	248	124	62	41	20.5	12.5	6.2	4.1

LC22G-107

減速比 Gear ratio	1/10	1/30	1/50	1/100	1/150	1/300	1/500	1/1000	1/1500
定格許容トルク Rated torque mN·m	14.7	49.0	78.5	166.7	196.1	294.2			
定格回転数 Rated speed min ⁻¹	718	237	138	69	45	23.5	14	7.6	5.2
定格電流 Rated current A	0.1		0.11		0.12		0.1		0.07
無負荷回転数 No load speed min ⁻¹	800	267	160	80	53	26.5	16	8	5.3

LC22G-108

減速比 Gear ratio	1/10	1/30	1/50	1/100	1/150	1/300	1/500	1/1000	1/1500
定格許容トルク Rated torque mN·m	14.7	49.0	78.5	166.7	196.1	294.2			
定格回転数 Rated speed min ⁻¹	670	215	126	64.5	42.5	22	13.5	6.8	4.7
定格電流 Rated current A	0.2			0.17			0.15	0.11	0.08
無負荷回転数 No load speed min ⁻¹	720	240	144	72	48	24	14.5	7.2	4.8

特性図 PERFORMANCE CURVES

(数値は定格運転条件での代表値です。)

(Figures in the table are typical values under rated operating condition.)

Motor only

Gear ratio 1/100

Motor only

Gear ratio 1/100

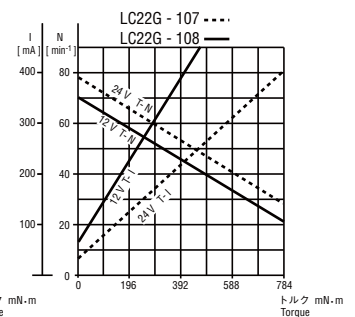
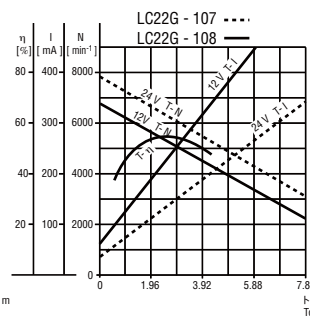
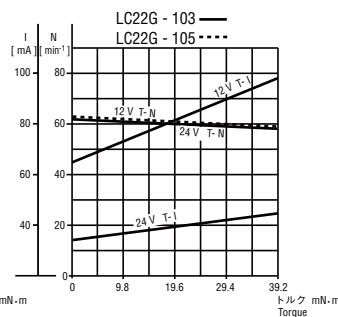
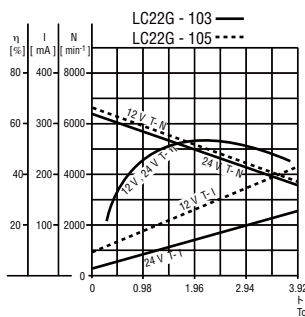

LC22G

DC GEARED MOTORS

外形寸法図 OUTLINE DIMENSIONS

(Unit: mm)

- LC22G-103
- LC22G-105

4 - M2 × 0.4 (D = 4.4)

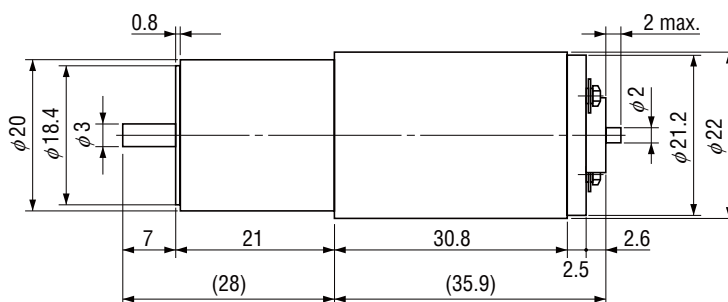
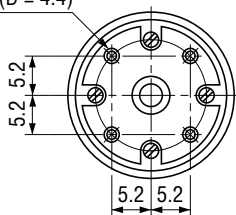

- LC22G-107
- LC22G-108

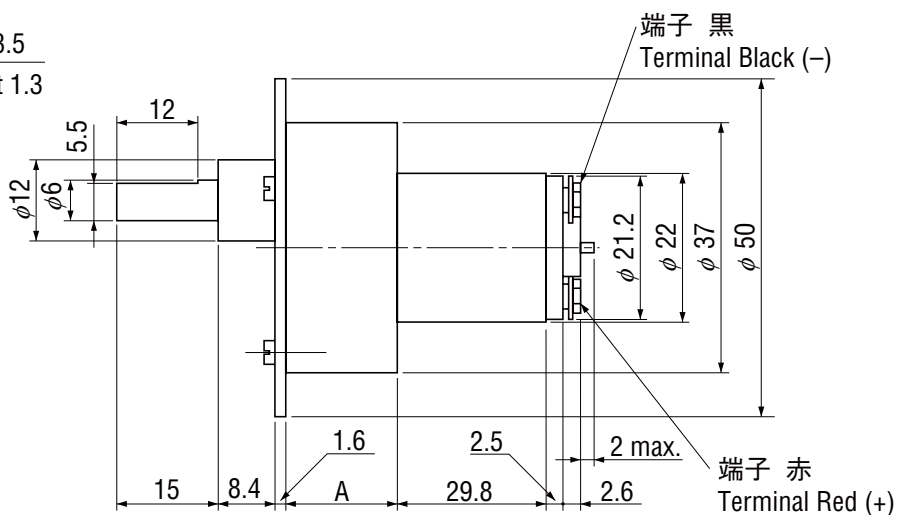
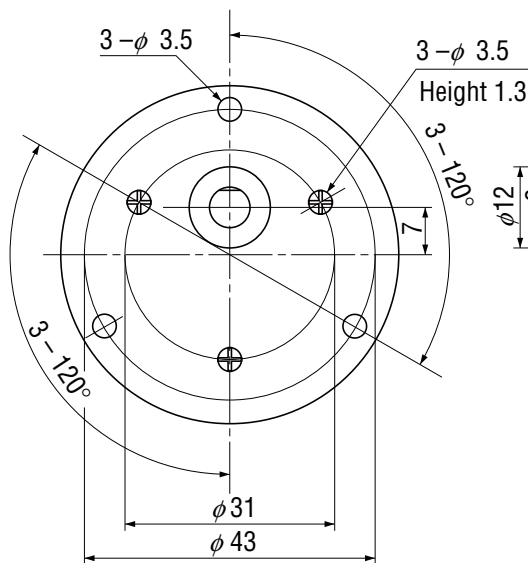

付法記号 Marks A

Gear ratio	1/10	1/30	1/50	1/100	1/150	1/300	1/500	1/1000	1/1500
A	16.5	19.0	21.5	24.0	26.5	29.0			