

ACCEPTANCE SHEET

ACCEPTOR MARUTSU ELEC CO.,LTD.

MERCHANDISE DISC CERAMIC CAPACITORS-RoHS

Y5P 152K/332K/682K 50V

Y5U 333M 50V

Z5V 153Z 50V

Y5P 101K/151K 1KV

Y5P 221K/331K 1KV

Y5P 471K/681K 1KV

Y5P 102K/152K 1KV

Y5P 222K/332K 1KV

Y5P 472K/682K 1KV

INSPECTOR 王國一 DATE 2017/4/17

MECHANICAL :

Thickness (T) : 3.0 mm Max.
 Lead Diameter : 0.45 mm ± 0.05 mm
 Soldering Test : 250 °C ± 5 °C
 Pulling Test : 2 KG
 Marking :

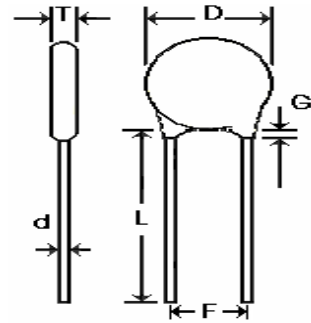
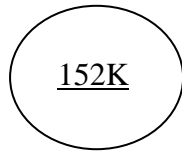

ELECTRICAL :

Capacitance : 1500PF
 Capacitance Tolerance : + - 10 %
 or DF : 0.025 Max.

External Dimensions (D)	5mm ± 1mm
Lead Spacing (F)	5mm ± 0.5mm
Thickness (T)	3mm Max.
Lead Length (L)	25mm ± 3mm
Lead Diameter (d)	0.45mm ± 0.05mm
Lead Coating (G)	1.5mm Max.

Insulation Resistance : ≥ 10000MΩ
 Working Voltage : 50 V DC
 Dielectric Withstanding : 125 V DC for 1~5 sec

Temperature Characteristic :

According to EIA Y5P The Capacitance change of + 10 - 10 %
 between the temperature range of - 25 °C ~ + 85 °C

TESTING INSTRUMENTS :

- 1 . TEMPERATURE COMPENSATING TYPE : hp 4278A
- 2 . HIGH DIELECTRIC TYPE : hp 4265A

TESTING CONDITIONS :

Testing Frequency : 1KHz
 Testing Voltage : 1.0Vrms

* 備註：耐壓100VDc以下，均需符合Coating之可漏底不漏銀電極的制作規範

CUSTOMER REF NO :
 UCC REF NO : CY5P152K1H05DS225

DATE : 2017/4/17
 APPROVER : 劉淑貞

MECHANICAL :

Thickness (T) : 3.0 mm Max.
 Lead Diameter : 0.45 mm ± 0.05 mm
 Soldering Test : 250 °C ± 5 °C
 Pulling Test : 2 KG
 Marking :

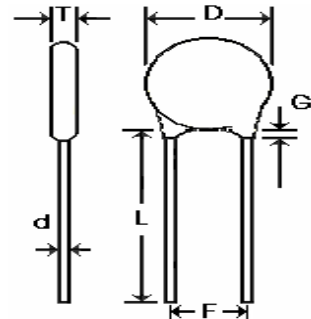
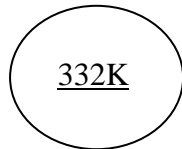

ELECTRICAL :

Capacitance : 3300PF
 Capacitance Tolerance : + - 10 %
 or DF : 0.025 Max.

External Dimensions (D)	6mm ± 1mm
Lead Spacing (F)	5mm ± 0.5mm
Thickness (T)	3mm Max.
Lead Length (L)	25mm ± 3mm
Lead Diameter (d)	0.45mm ± 0.05mm
Lead Coating (G)	1.5mm Max.

Insulation Resistance : ≥ 10000MΩ
 Working Voltage : 50 V DC
 Dielectric Withstanding : 125 V DC for 1~5 sec

Temperature Characteristic :

According to EIA Y5P The Capacitance change of + 10 - 10 %
 between the temperature range of - 25 °C ~ + 85 °C

TESTING INSTRUMENTS :

- 1 . TEMPERATURE COMPENSATING TYPE : hp 4278A
- 2 . HIGH DIELECTRIC TYPE : hp 4265A

TESTING CONDITIONS :

Testing Frequency : 1KHz
 Testing Voltage : 1.0Vrms

* 備註：耐壓100VDc以下，均需符合Coating之可漏底不漏銀電極的制作規範

CUSTOMER REF NO :
 UCC REF NO : CY5P332K1H06DS225

DATE : 2017/4/17
 APPROVER : 劉淑貞

MECHANICAL :

Thickness (T) : 3.0 mm Max.
 Lead Diameter : 0.45 mm ± 0.05 mm
 Soldering Test : 250 °C ± 5 °C
 Pulling Test : 2 KG
 Marking :

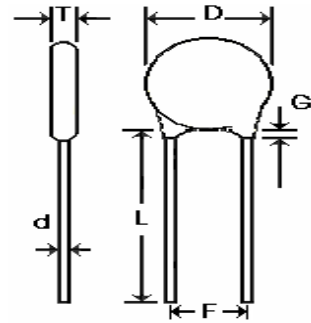
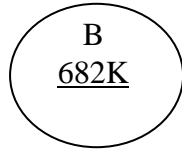

ELECTRICAL :

Capacitance : 6800PF
 Capacitance Tolerance : + - 10 %
 Q or DF : 0.025 Max.

External Dimensions (D)	8mm ± 1mm
Lead Spacing (F)	5mm ± 0.5mm
Thickness (T)	3mm Max.
Lead Length (L)	25mm ± 3mm
Lead Diameter (d)	0.45mm ± 0.05mm
Lead Coating (G)	1.5mm Max.

Insulation Resistance : ≥ 10000MΩ
 Working Voltage : 50 V DC
 Dielectric Withstanding : 125 V DC for 1~5 sec

Temperature Characteristic :

According to EIA Y5P The Capacitance change of + 10 - 10 %
 between the temperature range of - 25 °C ~ + 85 °C

TESTING INSTRUMENTS :

- 1 . TEMPERATURE COMPENSATING TYPE : hp 4278A
- 2 . HIGH DIELECTRIC TYPE : hp 4265A

TESTING CONDITIONS :

Testing Frequency : 1KHz
 Testing Voltage : 1.0Vrms

* 備註：耐壓100VDc以下，均需符合Coating之可漏底不漏銀電極的制作規範

CUSTOMER REF NO :
 UCC REF NO : CY5P682K1H08DS225

DATE : 2017/4/17
 APPROVER : 劉淑貞

MECHANICAL :

Thickness (T) : 3 mm Max.
 Lead Diameter : 0.45 mm ± 0.05 mm
 Soldering Test : 250 °C ± 5 °C
 Pulling Test : 2 KG
 Marking :

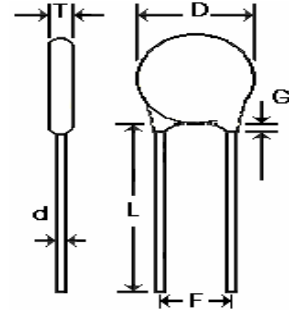
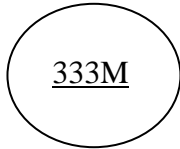

ELECTRICAL :

Capacitance : 0.033UF
 Capacitance Tolerance : + - 20 %
~~Q~~ or DF : 0.05 Max.

External Dimensions (D)	5mm ± 1.5mm
Lead Spacing (F)	5mm ± 0.8mm
Thickness (T)	3mm Max.
Lead Length (L)	25mm ± 3mm
Lead Diameter (d)	0.45mm ± 0.05mm
Lead Coating (G)	1.5mm Max.

Insulation Resistance : ≥ 1000MΩ
 Working Voltage : 50 V DC
 Dielectric Withstanding : 100 V DC for 1~5 sec

Temperature Characteristic :

According to EIA Y5U The Capacitance change of + 22 - 56 %
 between the temperature range of - 25 °C ~ + 85 °C

TESTING INSTRUMENTS :

- 1 . TEMPERATURE COMPENSATING TYPE : hp 4278A
- 2 . HIGH DIELECTRIC TYPE : hp 4265A

TESTING CONDITIONS :

Testing Frequency : 1KHz
 Testing Voltage : 0.5Vrms

* 備註：耐壓100VDc以下，均需符合Coating之可漏底不漏銀電極的制作規範

CUSTOMER REF NO :
 UCC REF NO : CY5U333M1H05DS225

DATE : 2017/4/17
 APPROVER : 劉淑貞

MECHANICAL :

Thickness (T) : 3 mm Max.
 Lead Diameter : 0.45 mm ± 0.05 mm
 Soldering Test : 250 °C ± 5 °C
 Pulling Test : 2 KG
 Marking :

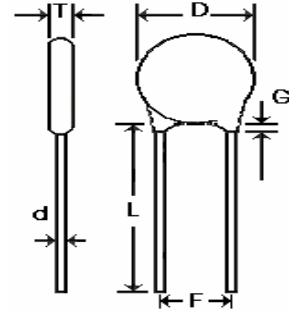
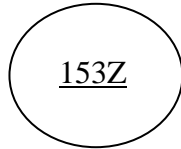

ELECTRICAL :

Capacitance : 0.015UF
 Capacitance Tolerance : + 80 - 20 %
 Q or DF : 0.05 Max.

External Dimensions (D)	6mm ± 1mm
Lead Spacing (F)	5mm ± 0.8mm
Thickness (T)	3mm Max.
Lead Length (L)	25mm ± 3mm
Lead Diameter (d)	0.45mm ± 0.05mm
Lead Coating (G)	1.5mm Max.

Insulation Resistance : ≥ 10000MΩ
 Working Voltage : 50 V DC
 Dielectric Withstanding : 100 V DC for 1~5 sec

Temperature Characteristic :

According to EIA Z5V The Capacitance change of + 22 ~ - 82 %
 between the temperature range of + 10 °C ~ + 85 °C

TESTING INSTRUMENTS :

- 1 . TEMPERATURE COMPENSATING TYPE : hp 4278A
- 2 . HIGH DIELECTRIC TYPE : hp 4265A

TESTING CONDITIONS :

Testing Frequency : 1KHz
 Testing Voltage : 1.0Vrms

* 備註：耐壓100VDc以下，均需符合Coating之可漏底不漏銀電極的制作規範

CUSTOMER REF NO :
 UCC REF NO : CZ5V153Z1H06DS225

DATE : 2017/4/17
 APPROVER : 劉淑貞

MECHANICAL :

Thickness (T) : 3.8 mm Max.
 Lead Diameter : 0.55 mm ± 0.05 mm
 Soldering Test : 250 °C ± 5 °C
 Pulling Test : 2 KG
 Marking :

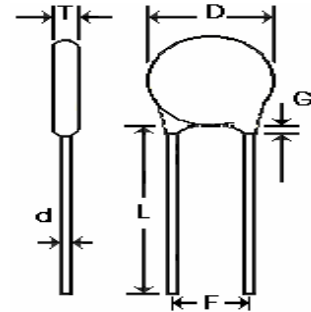
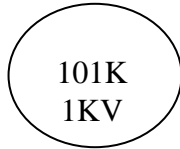

ELECTRICAL :

Capacitance : 100PF
 Capacitance Tolerance : + - 10 %
 \varnothing or DF : 0.025 Max.

External Dimensions (D)	5mm ± 1.5mm
Lead Spacing (F)	5mm ± 0.8mm
Thickness (T)	3.8mm Max.
Lead Length (L)	25mm ± 3mm
Lead Diameter (d)	0.55mm ± 0.05mm
Lead Coating (G)	2.0mm Max.

Insulation Resistance : $\geq 10000M\Omega$
 Working Voltage : 1K V DC
 Dielectric Withstanding : 1.5K V DC for 1~5 sec

Temperature Characteristic :

According to EIA Y5P The Capacitance change of + 10 - 10 %
 between the temperature range of - 25 °C ~ + 85 °C

TESTING INSTRUMENTS :

- 1 . TEMPERATURE COMPENSATING TYPE : hp 4278A
- 2 . HIGH DIELECTRIC TYPE : hp 4265A

TESTING CONDITIONS :

Testing Frequency : 1KHz
 Testing Voltage : 1.0Vrms

CUSTOMER REF NO :
 UCC REF NO : CY5P101K1K05DS125

DATE : 2017/4/17
 APPROVER : 劉淑貞

MECHANICAL :

Thickness (T) : 3.8 mm Max.
 Lead Diameter : 0.55 mm ± 0.05 mm
 Soldering Test : 250 °C ± 5 °C
 Pulling Test : 2 KG
 Marking :

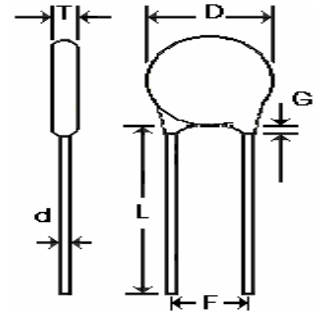
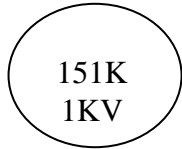

ELECTRICAL :

Capacitance : 150PF
 Capacitance Tolerance : + - 10 %
 Q or DF : 0.025 Max.

External Dimensions (D)	5mm ± 1.5mm
Lead Spacing (F)	5mm ± 0.8mm
Thickness (T)	3.8mm Max.
Lead Length (L)	25mm ± 3mm
Lead Diameter (d)	0.55mm ± 0.05mm
Lead Coating (G)	2.0mm Max.

Insulation Resistance : ≥ 10000MΩ
 Working Voltage : 1K V DC
 Dielectric Withstanding : 1.5K V DC for 1~5 sec

Temperature Characteristic :

According to EIA Y5P The Capacitance change of + 10 - 10 %
 between the temperature range of - 25 °C ~ + 85 °C

TESTING INSTRUMENTS :

- 1 . TEMPERATURE COMPENSATING TYPE : hp 4278A
- 2 . HIGH DIELECTRIC TYPE : hp 4265A

TESTING CONDITIONS :

Testing Frequency : 1KHz
 Testing Voltage : 1.0Vrms

CUSTOMER REF NO :
 UCC REF NO : CY5P151K1K05DS125

DATE : 2017/4/17
 APPROVER : 劉淑貞

MECHANICAL :

Thickness (T) : 3.8 mm Max.
 Lead Diameter : 0.55 mm ± 0.05 mm
 Soldering Test : 250 °C ± 5 °C
 Pulling Test : 2 KG
 Marking :

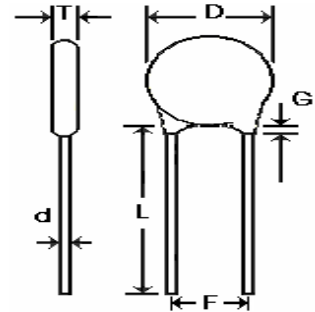

ELECTRICAL :

Capacitance : 220PF
 Capacitance Tolerance : + - 10 %
 Q or DF : 0.025 Max.

External Dimensions (D)	5mm ± 1.5mm
Lead Spacing (F)	5mm ± 0.8mm
Thickness (T)	3.8mm Max.
Lead Length (L)	25mm ± 3mm
Lead Diameter (d)	0.55mm ± 0.05mm
Lead Coating (G)	2.0mm Max.

Insulation Resistance : ≥ 10000MΩ
 Working Voltage : 1K V DC
 Dielectric Withstanding : 1.5K V DC for 1~5 sec

Temperature Characteristic :

According to EIA Y5P The Capacitance change of + 10 - 10 %
 between the temperature range of - 25 °C ~ + 85 °C

TESTING INSTRUMENTS :

- 1 . TEMPERATURE COMPENSATING TYPE : hp 4278A
- 2 . HIGH DIELECTRIC TYPE : hp 4265A

TESTING CONDITIONS :

Testing Frequency : 1KHz
 Testing Voltage : 1.0Vrms

CUSTOMER REF NO :
 UCC REF NO : CY5P221K1K05DS125

DATE : 2017/4/17
 APPROVER : 劉淑貞

MECHANICAL :

Thickness (T) : 3.8 mm Max.
 Lead Diameter : 0.55 mm ± 0.05 mm
 Soldering Test : 250 °C ± 5 °C
 Pulling Test : 2 KG
 Marking :

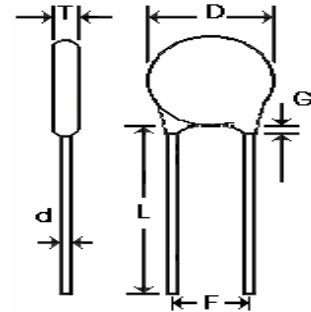
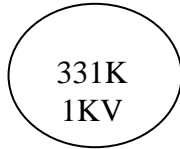

ELECTRICAL :

Capacitance : 330PF
 Capacitance Tolerance : + - 10 %
~~Q~~ or DF : 0.025 Max.

External Dimensions (D)	5mm ± 1.5mm
Lead Spacing (F)	5mm ± 0.8mm
Thickness (T)	3.8mm Max.
Lead Length (L)	25mm ± 3mm
Lead Diameter (d)	0.55mm ± 0.05mm
Lead Coating (G)	2.0mm Max.

Insulation Resistance : ≥ 10000MΩ
 Working Voltage : 1K V DC
 Dielectric Withstanding : 1.5K V DC for 1~5 sec

Temperature Characteristic :

According to EIA Y5P The Capacitance change of + 10 - 10 %
 between the temperature range of - 25 °C ~ + 85 °C

TESTING INSTRUMENTS :

- 1 . TEMPERATURE COMPENSATING TYPE : hp 4278A
- 2 . HIGH DIELECTRIC TYPE : hp 4265A

TESTING CONDITIONS :

Testing Frequency : 1KHz
 Testing Voltage : 1.0Vrms

CUSTOMER REF NO :
 UCC REF NO : CY5P331K1K05DS125

DATE : 2017/4/17
 APPROVER : 劉淑貞

MECHANICAL :

Thickness (T) : 3.8 mm Max.
 Lead Diameter : 0.55 mm ± 0.05 mm
 Soldering Test : 250 °C ± 5 °C
 Pulling Test : 2 KG
 Marking :

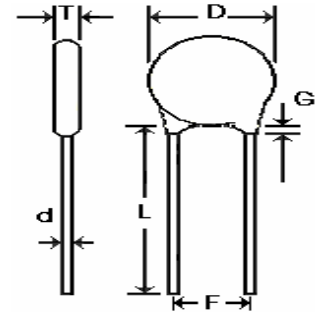
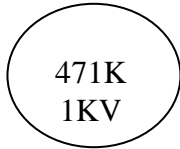

ELECTRICAL :

Capacitance : 470PF
 Capacitance Tolerance : + - 10 %
 Q or DF : 0.025 Max.

External Dimensions (D)	5mm ± 1.5mm
Lead Spacing (F)	5mm ± 0.8mm
Thickness (T)	3.8mm Max.
Lead Length (L)	25mm ± 3mm
Lead Diameter (d)	0.55mm ± 0.05mm
Lead Coating (G)	2.0mm Max.

Insulation Resistance : ≥ 10000MΩ
 Working Voltage : 1K V DC
 Dielectric Withstanding : 1.5K V DC for 1~5 sec

Temperature Characteristic :

According to EIA Y5P The Capacitance change of + 10 - 10 %
 between the temperature range of - 25 °C ~ + 85 °C

TESTING INSTRUMENTS :

- 1 . TEMPERATURE COMPENSATING TYPE : hp 4278A
- 2 . HIGH DIELECTRIC TYPE : hp 4265A

TESTING CONDITIONS :

Testing Frequency : 1KHz
 Testing Voltage : 1.0Vrms

CUSTOMER REF NO :
 UCC REF NO : CY5P471K1K05DS125

DATE : 2017/4/17
 APPROVER : 劉淑貞

MECHANICAL :

Thickness (T) : 3.8 mm Max.
 Lead Diameter : 0.55 mm ± 0.05 mm
 Soldering Test : 250 °C ± 5 °C
 Pulling Test : 2 KG
 Marking :

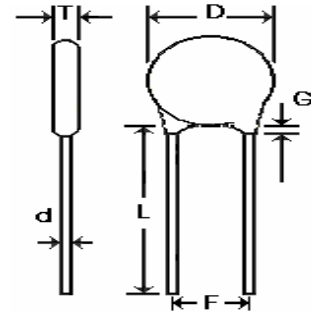
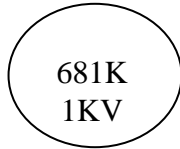

ELECTRICAL :

Capacitance : 680PF
 Capacitance Tolerance : + - 10 %
 Q or DF : 0.025 Max.

External Dimensions (D)	5mm ± 1.5mm
Lead Spacing (F)	5mm ± 0.8mm
Thickness (T)	3.8mm Max.
Lead Length (L)	25mm ± 3mm
Lead Diameter (d)	0.55mm ± 0.05mm
Lead Coating (G)	2.0mm Max.

Insulation Resistance : ≥ 10000MΩ
 Working Voltage : 1K V DC
 Dielectric Withstanding : 1.5K V DC for 1~5 sec

Temperature Characteristic :

According to EIA Y5P The Capacitance change of + 10 - 10 %
 between the temperature range of - 25 °C ~ + 85 °C

TESTING INSTRUMENTS :

- 1 . TEMPERATURE COMPENSATING TYPE : hp 4278A
- 2 . HIGH DIELECTRIC TYPE : hp 4265A

TESTING CONDITIONS :

Testing Frequency : 1KHz
 Testing Voltage : 1.0Vrms

CUSTOMER REF NO :
 UCC REF NO : CY5P681K1K05DS125

DATE : 2017/4/17
 APPROVER : 劉淑貞

MECHANICAL :

Thickness (T) : 3.8 mm Max.
 Lead Diameter : 0.55 mm ± 0.05 mm
 Soldering Test : 250 °C ± 5 °C
 Pulling Test : 2 KG
 Marking :

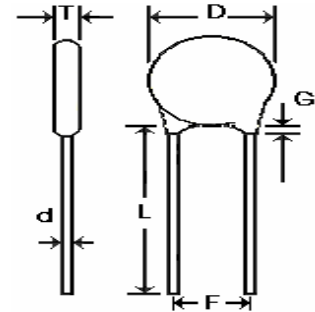
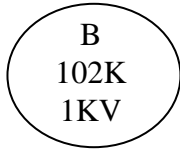

ELECTRICAL :

Capacitance : 1000PF
 Capacitance Tolerance : + - 10 %
~~Q~~ or DF : 0.025 Max.

External Dimensions (D)	7mm ± 1.5mm
Lead Spacing (F)	5mm ± 0.8mm
Thickness (T)	3.8mm Max.
Lead Length (L)	25mm ± 3mm
Lead Diameter (d)	0.55mm ± 0.05mm
Lead Coating (G)	2.0mm Max.

Insulation Resistance : ≥ 10000MΩ
 Working Voltage : 1K V DC
 Dielectric Withstanding : 1.5K V DC for 1~5 sec

Temperature Characteristic :

According to EIA Y5P The Capacitance change of + 10 - 10 %
 between the temperature range of - 25 °C ~ + 85 °C

TESTING INSTRUMENTS :

- 1 . TEMPERATURE COMPENSATING TYPE : hp 4278A
- 2 . HIGH DIELECTRIC TYPE : hp 4265A

TESTING CONDITIONS :

Testing Frequency : 1KHz
 Testing Voltage : 1.0Vrms

CUSTOMER REF NO :
 UCC REF NO : CY5P102K1K07DS125

DATE : 2017/4/17
 APPROVER : 劉淑貞

MECHANICAL :

Thickness (T) : 3.8 mm Max.
 Lead Diameter : 0.55 mm ± 0.05 mm
 Soldering Test : 250 °C ± 5 °C
 Pulling Test : 2 KG
 Marking :

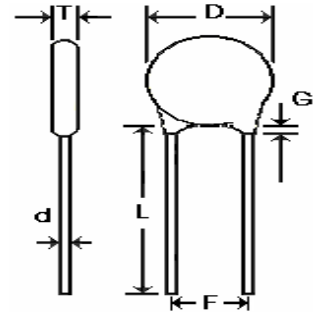
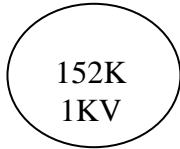

ELECTRICAL :

Capacitance : 1500PF
 Capacitance Tolerance : + - 10 %
~~Q~~ or DF : 0.025 Max.

External Dimensions (D)	7mm ± 1.5mm
Lead Spacing (F)	5mm ± 0.8mm
Thickness (T)	3.8mm Max.
Lead Length (L)	25mm ± 3mm
Lead Diameter (d)	0.55mm ± 0.05mm
Lead Coating (G)	2.0mm Max.

Insulation Resistance : ≥ 10000MΩ
 Working Voltage : 1K V DC
 Dielectric Withstanding : 1.5K V DC for 1~5 sec

Temperature Characteristic :

According to EIA Y5P The Capacitance change of + 10 - 10 %
 between the temperature range of - 25 °C ~ + 85 °C

TESTING INSTRUMENTS :

- 1 . TEMPERATURE COMPENSATING TYPE : hp 4278A
- 2 . HIGH DIELECTRIC TYPE : hp 4265A

TESTING CONDITIONS :

Testing Frequency : 1KHz
 Testing Voltage : 1.0Vrms

CUSTOMER REF NO :
 UCC REF NO : CY5P152K1K07DS125

DATE : 2017/4/17
 APPROVER : 劉淑貞

MECHANICAL :

Thickness (T) : 3.8 mm Max.
 Lead Diameter : 0.55 mm ± 0.05 mm
 Soldering Test : 250 °C ± 5 °C
 Pulling Test : 2 KG
 Marking :

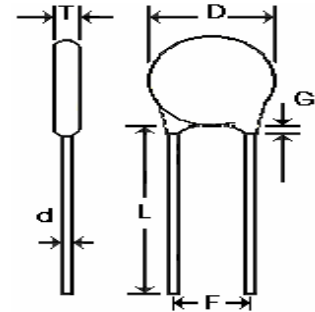
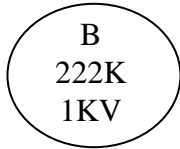

ELECTRICAL :

Capacitance : 2200PF
 Capacitance Tolerance : + - 10 %
~~Q~~ or DF : 0.025 Max.

External Dimensions (D)	9mm ± 1.5mm
Lead Spacing (F)	5mm ± 0.8mm
Thickness (T)	3.8mm Max.
Lead Length (L)	25mm ± 3mm
Lead Diameter (d)	0.55mm ± 0.05mm
Lead Coating (G)	2.0mm Max.

Insulation Resistance : ≥ 10000MΩ
 Working Voltage : 1K V DC
 Dielectric Withstanding : 1.5K V DC for 1~5 sec

Temperature Characteristic :

According to EIA Y5P The Capacitance change of + 10 - 10 %
 between the temperature range of - 25 °C ~ + 85 °C

TESTING INSTRUMENTS :

- 1 . TEMPERATURE COMPENSATING TYPE : hp 4278A
- 2 . HIGH DIELECTRIC TYPE : hp 4265A

TESTING CONDITIONS :

Testing Frequency : 1KHz
 Testing Voltage : 1.0Vrms

CUSTOMER REF NO :
 UCC REF NO : CY5P222K1K09DS125

DATE : 2017/4/17
 APPROVER : 劉淑貞

MECHANICAL :

Thickness (T) : 3.8 mm Max.
 Lead Diameter : 0.55 mm ± 0.05 mm
 Soldering Test : 250 °C ± 5 °C
 Pulling Test : 2 KG
 Marking :

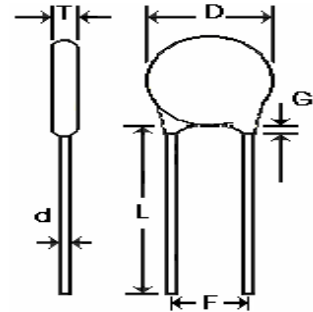
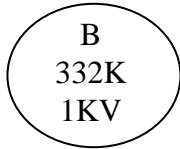

ELECTRICAL :

Capacitance : 3300PF
 Capacitance Tolerance : + - 10 %
~~Q~~ or DF : 0.025 Max.

External Dimensions (D)	10mm ± 1.5mm
Lead Spacing (F)	5mm ± 0.8mm
Thickness (T)	3.8mm Max.
Lead Length (L)	25mm ± 3mm
Lead Diameter (d)	0.55mm ± 0.05mm
Lead Coating (G)	2.0mm Max.

Insulation Resistance : ≥ 10000MΩ
 Working Voltage : 1K V DC
 Dielectric Withstanding : 1.5K V DC for 1~5 sec

Temperature Characteristic :

According to EIA Y5P The Capacitance change of + 10 - 10 %
 between the temperature range of - 25 °C ~ + 85 °C

TESTING INSTRUMENTS :

- 1 . TEMPERATURE COMPENSATING TYPE : hp 4278A
- 2 . HIGH DIELECTRIC TYPE : hp 4265A

TESTING CONDITIONS :

Testing Frequency : 1KHz
 Testing Voltage : 1.0Vrms

CUSTOMER REF NO :
 UCC REF NO : CY5P332K1K10DS125

DATE : 2017/4/17
 APPROVER : 劉淑貞

MECHANICAL :

Thickness (T) : 3.8 mm Max.
 Lead Diameter : 0.55 mm ± 0.05 mm
 Soldering Test : 250 °C ± 5 °C
 Pulling Test : 2 KG
 Marking :

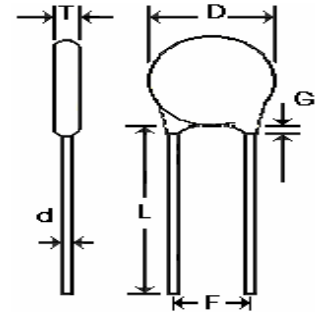
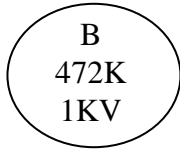

ELECTRICAL :

Capacitance : 4700PF
 Capacitance Tolerance : + - 10 %
 or DF : 0.025 Max.

External Dimensions (D)	12mm ± 1.5mm
Lead Spacing (F)	5mm ± 0.8mm
Thickness (T)	3.8mm Max.
Lead Length (L)	25mm ± 3mm
Lead Diameter (d)	0.55mm ± 0.05mm
Lead Coating (G)	2.0mm Max.

Insulation Resistance : ≥ 10000MΩ
 Working Voltage : 1K V DC
 Dielectric Withstanding : 1.5K V DC for 1~5 sec

Temperature Characteristic :

According to EIA Y5P The Capacitance change of + 10 - 10 %
 between the temperature range of - 25 °C ~ + 85 °C

TESTING INSTRUMENTS :

- 1 . TEMPERATURE COMPENSATING TYPE : hp 4278A
- 2 . HIGH DIELECTRIC TYPE : hp 4265A

TESTING CONDITIONS :

Testing Frequency : 1KHz
 Testing Voltage : 1.0Vrms

CUSTOMER REF NO :
 UCC REF NO : CY5P472K1K12DS125

DATE : 2017/4/17
 APPROVER : 劉淑貞

MECHANICAL :

Thickness (T) : 3.8 mm Max.
 Lead Diameter : 0.6 mm ± 0.05 mm
 Soldering Test : 250 °C ± 5 °C
 Pulling Test : 2 KG
 Marking :

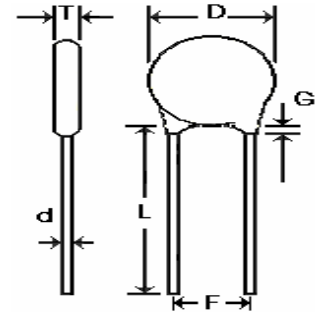
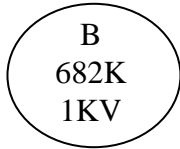

ELECTRICAL :

Capacitance : 6800PF
 Capacitance Tolerance : + - 10 %
 or DF : 0.025 Max.

External Dimensions (D)	14mm ± 1.5mm
Lead Spacing (F)	10mm ± 0.8mm
Thickness (T)	3.8mm Max.
Lead Length (L)	25mm ± 3mm
Lead Diameter (d)	0.6mm ± 0.05mm
Lead Coating (G)	2.0mm Max.

Insulation Resistance : ≥ 10000MΩ
 Working Voltage : 1K V DC
 Dielectric Withstanding : 1.5K V DC for 1~5 sec

Temperature Characteristic :

According to EIA Y5P The Capacitance change of + 10 - 10 %
 between the temperature range of - 25 °C ~ + 85 °C

TESTING INSTRUMENTS :

- 1 . TEMPERATURE COMPENSATING TYPE : hp 4278A
- 2 . HIGH DIELECTRIC TYPE : hp 4265A

TESTING CONDITIONS :

Testing Frequency : 1KHz
 Testing Voltage : 1.0Vrms

CUSTOMER REF NO :
 UCC REF NO : CY5P682K1K14GS125

DATE : 2017/4/17
 APPROVER : 劉淑貞

DISC CERAMIC CAPACITORS

5.0 Specification

No	Item	Class I	Class II	Class III	Measuring Condition															
1	Visual and mechanical examination	To be within the specifications shows in			Capacitors shall be visually inspected for visible evidence of defect. Dimensions shall be measured with calipers or micrometers. Marking shall be legibility.															
2	Operating Temperature Range	- 25°C to +85°C	Y5E 、 Y5F 、 Y5P : - 25°C to +85°C Z5U 、 Z5V : +10°C to +85°C	Y5V & Y5U & Y5P : - 25°C to +85°C	Class III is semi-conductor material															
3	Temperature Characteristics	NPO(CH) : 0 ± 60ppm/°C UJ : - 750 ± 120ppm/°C SL : +350 to- 1000ppm/°C	Y5E : ± 4.7% Y5F : ± 7.5% Y5P : ± 10% Z5U : +22 -56 % Z5V : +22 -82 %	Y5U : +22 -56 % Y5V : +22 -82 % Y5P : ±10 %	Retain the sample for 30 minutes at the temperature specified below in the sequence listed in the table. Then measure the capacitance in each step after thermal equilibrium at each temperature is reached. <table border="1" style="width: 100%; text-align: center;"> <thead> <tr> <th>Step 1</th> <th>Step 2</th> <th>Step 3</th> <th>Step 4</th> <th>Step 5</th> </tr> </thead> <tbody> <tr> <td>Room Temp.</td> <td>Min. Operating Temp.</td> <td>Room Temp.</td> <td>Max. Operating Temp.</td> <td>Room Temp.</td> </tr> <tr> <td>25±2°C</td> <td>-25±3°C 10±2°C</td> <td>25±2°C</td> <td>85±2°C</td> <td>25±2°C</td> </tr> </tbody> </table> Note that step 1 and 2 do not apply for the SL characteristics.	Step 1	Step 2	Step 3	Step 4	Step 5	Room Temp.	Min. Operating Temp.	Room Temp.	Max. Operating Temp.	Room Temp.	25±2°C	-25±3°C 10±2°C	25±2°C	85±2°C	25±2°C
Step 1	Step 2	Step 3	Step 4	Step 5																
Room Temp.	Min. Operating Temp.	Room Temp.	Max. Operating Temp.	Room Temp.																
25±2°C	-25±3°C 10±2°C	25±2°C	85±2°C	25±2°C																
4	Capacitance	To be within the specified tolerance			Shall be measured at 25°C ± 2°C normal temperature at the frequency and voltage															
5	Q or Dissipation Factor (tan δ)	C ≥ 30pF : Q ≥ 1000 C < 30pF : Q ≥ 400 + 20 × C (C is nominal capacitance)	Y5E & Y5F & Y5P & Z5U : tan δ ≤ 0.025 Z5V : tan δ ≤ 0.05	Y5U & Y5V & Y5P : tan δ ≤ 0.05	Class I : 1MHz ± 20% , 1 ± 0.2Vrms Class II : 1KHz ± 10% , 1 ± 0.2Vrms Class III : 1KHz ± 10% , 0.5 ± 0.05Vrms															
6	Withstanding Voltage	No defects			Applied voltage : Rated voltage ×3 (Class I) Rated voltage ×2.5 (Class II) Rated voltage ×2 (Class III) Duration : 1 to 5 sec. The charge/discharge current is less than 50mA															
7	Insulation Resistance	More than 10GΩ	More than 10GΩ or 200MΩ • F, whichever is less.	More than 1GΩ or 20MΩ • F, whichever is less.	Apply rated voltage for 1 minute at 25°C ± 2°C and 70% R.H. max. 16Vdc product : Measurement voltage is 25Vdc															
8	Strength of Lead	Termination not to be broken or loosened			Fix the capacitor, apply the tensile stress listed below in the terminal extraction direction until the designated value is reached, then retain the capacitor for 10 ± 1 seconds as is. <table border="1" style="width: 100%; text-align: center;"> <tbody> <tr> <td>Nominal wire diameter</td> <td>0.5mm</td> <td>0.6mm</td> </tr> <tr> <td>Tensile stress</td> <td>1kg</td> <td>1.5kg</td> </tr> </tbody> </table>	Nominal wire diameter	0.5mm	0.6mm	Tensile stress	1kg	1.5kg									
Nominal wire diameter	0.5mm	0.6mm																		
Tensile stress	1kg	1.5kg																		
9	Solderability of leads	At least 75% of the immersed surface in the circumference direction is covered with new solder.			Solder temperature : Class I ; 260 ± 5°C Class II、 III ; 250 ± 5°C Dipping : 2 ± 0.5 sec. (Flux shall be used)															

DISC CERAMIC CAPACITORS

5.0 Specification

No	Item	Class I	Class II	Class III	Measuring Condition																
10	Resistance to Soldering heat	ΔC	± 2.5% or ± 0.25pF (Whichever is greater)	Y5E 、 Y5F 、 Y5P : ± 5% Z5U : ± 15% Z5V : ± 20%	Y5U & Y5V : ± 30% Y5P : ± 7.5%	The lead wire is immersed in the melted solder 1.5mm to 2mm from the capacitor body (Class I, II) Solder temperature : 350 ± 10°C Duration : 3 ± 0.5sec. (Class III) Solder temperature : 260 ± 5°C Duration : 5 ± 0.5sec. The measurements after testing must be taken after leaving the sample for 12 to 24 hours under normal temperature and humidity conditions.															
		Withstanding voltage	No defects																		
		Exterior	No abnormalities																		
11	Temperature and Immersion cycling	ΔC	± 5% or ± 0.5pF (Whichever is greater)	Y5E 、 Y5F 、 Y5P : ± 10% Z5U : ± 20% Z5V : ± 30%	Y5U & Y5V : ± 30% Y5P : ± 15 %	Fix the capacitor to the supporting jig in the same manner and under the same conditions as (10). Perform the 5 cycles according to the four heat treatments listed in the following table. <table border="1" style="margin: 5px 0; width: 100%; text-align: center;"> <thead> <tr> <th>Step</th> <th>1</th> <th>2</th> <th>3</th> <th>4</th> </tr> </thead> <tbody> <tr> <td>Temp. (°C)</td> <td>Min. Operating Temp.</td> <td>Room Temp.</td> <td>Max. Operating Temp.</td> <td>Room Temp.</td> </tr> <tr> <td>Time (min.)</td> <td>30±3</td> <td>15</td> <td>30±3</td> <td>15</td> </tr> </tbody> </table> The measurements after testing must be taken after leaving the sample for 12 to 24 hours under normal temperature and humidity conditions.	Step	1	2	3	4	Temp. (°C)	Min. Operating Temp.	Room Temp.	Max. Operating Temp.	Room Temp.	Time (min.)	30±3	15	30±3	15
		Step	1	2	3		4														
		Temp. (°C)	Min. Operating Temp.	Room Temp.	Max. Operating Temp.		Room Temp.														
		Time (min.)	30±3	15	30±3		15														
		Q/D.F.	C ≥ 30pF : Q ≥ 350 10pF > C < 30pF : $Q \geq 275 + \frac{5}{2} \times C$ C ≤ 10pF : Q ≥ 200 + 10 × C (C is nominal capacitance)	Y5E & Y5F & Y5P & Z5U : $\tan \delta \leq 0.05$ Z5V : $\tan \delta \leq 0.075$	Y5U & Y5P : $\tan \delta \leq 0.05$ Y5V : $\tan \delta \leq 0.075$																
		I.R.	More than 1GΩ	More than 1GΩ or 20MΩ • F, whichever is less.	More than 500MΩ or 10MΩ • F, whichever is less.																
Withstanding voltage	No defects																				
Exterior	No abnormalities																				
12	Humidity Loading	ΔC	± 7.5% or ± 0.75pF (Whichever is greater)	Y5E 、 Y5F 、 Y5P : ± 10% Z5U : ± 20% Z5V : ± 30%	Y5U & Y5V : ± 30% Y5P : ± 15 %	Temperature : 40 ± 2°C Humidity : 90 to 95% R.H. Duration : 500 ⁺²⁴ ₋₀ hrs. The rated voltage continuously applied. The charge/discharge current is less than 10mA. The measurements after testing must be taken after leaving the sample for 1 to 2 hours under normal temperature and humidity conditions. • Perform a heat treatment at 40 ± 2°C for 1 hour. Remove and let sit for 1 to 2 hours at normal temperature and humidity conditions. Perform the initial measurement.															
		Q/D.F.	C ≥ 30pF : Q ≥ 200 C < 30pF : $Q \geq 100 + \frac{10}{3} \times C$ (C is nominal capacitance)	Y5E & Y5F & Y5P & Z5U : $\tan \delta \leq 0.05$ Z5V : $\tan \delta \leq 0.075$	Y5U & Y5V & Y5P : $\tan \delta \leq 0.075$																
		I.R.	More than 1GΩ	More than 1GΩ or 20MΩ • F, whichever is less.	More than 500MΩ or 10MΩ • F, whichever is less.																
		Withstanding voltage	No defects																		
		Exterior	No abnormalities																		

DISC CERAMIC CAPACITORS

5.0 Specification

No	Item	Class I	Class II	Class III	Measuring Condition	
13	Life	ΔC	± 5% or ± 0.5pF (Whichever is greater)	Y5E · Y5F · Y5P : ± 10% Z5U : ± 20% Z5V : ± 30%	Y5U & Y5V : ± 30% Y5P : ± 15 %	Applied voltage : Rated voltage ×2(Class I, II) Rated voltage ×1.25(Class III) Temperature : 85± 2°C Duration : 1000 ⁺⁴⁸ ₋₀ hrs. The charge/discharge current is less than 10mA. The measurements after testing must be taken after leaving the sample for 12 to 24 hours under normal temperature and humidity conditions. • Perform a heat treatment at 85± 2°C for 1 hour. Remove and let sit for 12 to 24 hours at normal temperature and humidity conditions. Perform the initial measurement.
		Q/D.F.	C ≥ 30pF : Q ≥ 350 10pF > C < 30pF : $Q \geq 275 + \frac{5}{2} \times C$ C ≤ 10pF : Q ≥ 200 + 10 × C (C is nominal capacitance)	Y5E&Y5F&Y5P & Z5U : tan δ ≤ 0.05 Z5V : tan δ ≤ 0.075	Y5U & Y5V & Y5P : tan δ ≤ 0.075	
		I.R.	More than 1G Ω	More than 1G Ω or 20M Ω · F, whichever is less.	More than 500M Ω or 10M Ω · F, whichever is less.	
		Withstanding voltage	No defects			
		Exterior	No abnormalities			

* Note on standard condition : “standard condition” referred to herein is defined as follows :

5 to 35°C of temperature, 45 to 85% relative humidity, and 860 to 1060 mbar of air pressure.

When there are questions concerning measurement results :

In order to provide correlation data, the test shall be conducted under condition of 23°C ± 2°C of temperature, 60 to 70% relative humidity, and 860 to 1060 mbar of air

Pressure, Unless otherwise specified, all the tests are conducted under the “standard condition” .

6.0 Storage

1. The storage conditions should be:

Temperature = Lower than 40°C

Humidity = Lower than 70% R.H.

2. After opening the package, please store in desiccators.

DISC CERAMIC CAPACITORS

Medium-High Voltage Capacitor

7.0 Specification

No	Item	Class I	Class II	Measuring Condition															
1	Visual and mechanical examination	To be within the specifications shows in		Capacitors shall be visually inspected for visible evidence of defect. Dimensions shall be measured with calipers or micrometers. Marking shall be legibility.															
2	Operating Temperature Range	- 25°C to +85°C	Y5E 、 Y5P 、 Y5U 、 Y5V : - 25°C to +85°C Z5U 、 Z5V : +10°C to +85°C	Class III is semi-conductor material															
3	Temperature Characteristics	NPO(CH) : 0 ± 60ppm/°C UJ : - 750 ± 120ppm/°C SL : +350 to- 1000ppm/°C	Y5E : ± 4.7% Y5P : ± 10% Y5U : $\begin{matrix} +22 \\ -56 \end{matrix}$ % Z5U : $\begin{matrix} +22 \\ -56 \end{matrix}$ % Z5V 、 Y5V : $\begin{matrix} +22 \\ -82 \end{matrix}$ %	Retain the sample for 30 minutes at the temperature specified below in the sequence listed in the table. Then measure the capacitance in each step after thermal equilibrium at each temperature is reached. <table border="1"> <thead> <tr> <th>Step 1</th> <th>Step 2</th> <th>Step 3</th> <th>Step 4</th> <th>Step 5</th> </tr> </thead> <tbody> <tr> <td>Room Temp.</td> <td>Min. Operating Temp.</td> <td>Room Temp.</td> <td>Max. Operating Temp.</td> <td>Room Temp.</td> </tr> <tr> <td>25±2°C</td> <td>-25±3°C</td> <td>25±2°C</td> <td>85±2°C</td> <td>25±2°C</td> </tr> </tbody> </table> Note that step 1 and 2 do not apply for the SL characteristics.	Step 1	Step 2	Step 3	Step 4	Step 5	Room Temp.	Min. Operating Temp.	Room Temp.	Max. Operating Temp.	Room Temp.	25±2°C	-25±3°C	25±2°C	85±2°C	25±2°C
Step 1	Step 2	Step 3	Step 4	Step 5															
Room Temp.	Min. Operating Temp.	Room Temp.	Max. Operating Temp.	Room Temp.															
25±2°C	-25±3°C	25±2°C	85±2°C	25±2°C															
4	Capacitance	To be within the specified tolerance		Shall be measured at 25°C ± 2°C normal temperature at the frequency and voltage															
5	Q or Dissipation Factor (tan δ)	C ≥ 30pF : Q ≥ 1000 C < 30pF : Q ≥ 400 + 20 × C (C is nominal capacitance)	Y5E & Y5P & Y5U & Z5U : tan δ ≤ 0.025 Z5V 、 Y5V : tan δ ≤ 0.05	Class I : 1MHz ± 20% , 1 ± 0.2Vrms Class II : 1KHz ± 10% , 1 ± 0.2Vrms															
6	Withstanding Voltage	No defects between terminals	No defects between terminal and body	Applied voltage : Rated voltage × 2 (Class I) Rated voltage × 1.5 (Class II、 III) 5KV~7999V × 1.5 8KV~12KV × 1.2 Duration : 1 to 5 sec. The charge/discharge current is less than 50mA Applied voltage : 1.3kVdc Duration : 1 to 5 sec.															
7	Insulation Resistance	More than 10GΩ or 200MΩ · F, whichever is less. Y5V : More than 1GΩ or 20MΩ · F, whichever is less.		Apply 500Vdc for 1 minute at 25°C ± 2°C and 70% R.H. max.															
8	Strength of Lead	Termination not to be broken or loosened		Fix the capacitor, apply the tensile stress listed below in the terminal extraction direction until the designated value is reached, then retain the capacitor for 10 ± 1 seconds as is. Tensile stress ≥ 1.5kg															
9	Solderability of leads	At least three-fourths of the immersed surface in the circumference direction is covered with new solder.		Solder temperature : Class I : 260 ± 5°C Class II、 III : 250 ± 5°C Dipping : 2 ± 0.5 sec. (Flux shall be used)															

DISC CERAMIC CAPACITORS

Medium-High Voltage Capacitor

7.0 Specification

No	Item	Class I	Class II	Measuring Condition																
10	Resistance to Soldering heat	ΔC	$\pm 2.5\%$ or $\pm 0.25\text{pF}$ (Whichever is greater)	Y5E & Y5P : $\pm 5\%$ Y5U & Z5U : $\pm 15\%$ Z5V : $\pm 20\%$ Y5V : $\pm 30\%$	The lead wire is immersed in the melted solder 1.5mm to 2mm from the capacitor body (Class I, II, III) Solder temperature : $260 \pm 5^\circ\text{C}$ Duration : $5 \pm 0.5\text{sec.}$ The measurements after testing must be taken after leaving the sample for 12 to 24 hours under normal temperature and humidity conditions.															
		Withstanding voltage	No defects																	
		Exterior	No abnormalities																	
11	Temperature and Immersion cycling	ΔC	$\pm 5\%$ or $\pm 0.5\text{pF}$ (Whichever is greater)	Y5E & Y5P : $\pm 10\%$ Y5U & Z5U : $\pm 20\%$ Z5V : $\pm 30\%$ Y5V : $\pm 30\%$	Fix the capacitor to the supporting jig in the same manner and under the same conditions as (10). Perform the five cycles according to the four heat treatments listed in the following table. <table border="1" style="margin-left: auto; margin-right: auto;"> <thead> <tr> <th>Step</th> <th>1</th> <th>2</th> <th>3</th> <th>4</th> </tr> </thead> <tbody> <tr> <td>Temp. (°C)</td> <td>Min. Operating Temp.</td> <td>Room Temp.</td> <td>Max. Operating Temp.</td> <td>Room Temp.</td> </tr> <tr> <td>Time (min.)</td> <td>30 ± 3</td> <td>15</td> <td>30 ± 3</td> <td>15</td> </tr> </tbody> </table> The measurements after testing must be taken after leaving the sample for 12 to 24 hours under normal temperature and humidity conditions.	Step	1	2	3	4	Temp. (°C)	Min. Operating Temp.	Room Temp.	Max. Operating Temp.	Room Temp.	Time (min.)	30 ± 3	15	30 ± 3	15
		Step	1	2		3	4													
		Temp. (°C)	Min. Operating Temp.	Room Temp.		Max. Operating Temp.	Room Temp.													
		Time (min.)	30 ± 3	15		30 ± 3	15													
		Q/D.F.	$C \geq 30\text{pF} : Q \geq 350$ $10\text{pF} > C < 30\text{pF} :$ $Q \geq 275 + \frac{5}{2} \times C$ $C \leq 10\text{pF} : Q \geq 200 + 10 \times C$ (C is nominal capacitance)	Y5E & Y5P & Z5U & Y5U : $\tan \delta \leq 0.05$ Z5V、Y5V : $\tan \delta \leq 0.075$																
		I.R.	More than $1\text{G}\Omega$	More than $1\text{G}\Omega$ or $20\text{M}\Omega \cdot F$, whichever is less. Y5V : More than $500\text{M}\Omega$ or $10\text{M}\Omega \cdot F$, whichever is less.																
Withstanding voltage	No defects																			
Exterior	No abnormalities																			
12	Humidity Loading	ΔC	$\pm 7.5\%$ or $\pm 0.75\text{pF}$ (Whichever is greater)	Y5E、Y5P : $\pm 10\%$ Y5U & Z5U : $\pm 20\%$ Z5V、Y5V : $\pm 30\%$	Temperature : $40 \pm 2^\circ\text{C}$ Humidity : 90 to 95% R.H. Duration : 500_{-0}^{+24} hrs. The rated voltage continuously applied. The charge/discharge current is less than 10mA. The measurements after testing must be taken after leaving the sample for 1 to 2 hours under normal temperature and humidity conditions. • Perform a heat treatment at $40 \pm 2^\circ\text{C}$ for 1 hour. Remove and let sit for 1 to 2 hours at normal temperature and humidity conditions. Perform the initial measurement.															
		Q/D.F.	$C \geq 30\text{pF} : Q \geq 200$ $C < 30\text{pF} :$ $Q \geq 100 + \frac{10}{3} \times C$ (C is nominal capacitance)	Y5E & Y5P & Y5U & Z5U : $\tan \delta \leq 0.05$ Z5V、Y5V : $\tan \delta \leq 0.075$																
		I.R.	More than $500\text{M}\Omega$ Y5V : More than $500\text{M}\Omega$ or $10\text{M}\Omega \cdot F$, whichever is less.																	
		Withstanding voltage	No defects																	
		Exterior	No abnormalities																	

DISC CERAMIC CAPACITORS

Medium-High Voltage Capacitor

7.0 Specification

No	Item	Class I	Class II	Measuring Condition	
13	Life	ΔC	$\pm 5\%$ or $\pm 0.5\text{pF}$ (Whichever is greater)	Y5E 、 Y5P : $\pm 10\%$ Y5U & Z5U : $\pm 20\%$ Z5V 、 Y5V : $\pm 30\%$	Applied voltage : Rated voltage $\times 1.5$ (Class I) Rated voltage $\times 1.25$ (Class II, III) 8KV~12KV $\times 1$ Temperature : $85 \pm 2^\circ\text{C}$ Duration : 1000^{+48}_{-0} hrs. The charge/discharge current is less than 10mA. The measurements after testing must be taken after leaving the sample for 12 to 24 hours under normal temperature and humidity conditions. • Perform a heat treatment at $85 \pm 2^\circ\text{C}$ for 1 hour. Remove and let sit for 12 to 24 hours at normal temperature and humidity conditions. Perform the initial measurement.
		Q/D.F.	$C \geq 30\text{pF}$: $Q \geq 350$ $10\text{pF} > C < 30\text{pF}$: $Q \geq 275 + \frac{5}{2} \times C$	Y5E 、 Y5P 、 Z5U 、 Y5U : $\tan \delta \leq 0.05$ Z5V 、 Y5V : $\tan \delta \leq 0.075$	
		I.R.	More than $1\text{G}\Omega$	More than $1\text{G}\Omega$ or $20\text{M}\Omega \cdot \text{F}$, whichever is less. Y5V : More than $500\text{M}\Omega$ or $10\text{M}\Omega \cdot \text{F}$, whichever is less.	
		Withstanding voltage	No defects		
		Exterior	No abnormalities		