

Renesas RA Family

FPB-RA6E1 Fast Prototyping Board

1. Introduction

The FPB-RA6E1 Fast Prototyping Board provides an entry point for evaluation, prototyping and development with the RA6E1 MCU. Moreover, since this board incorporates an emulator circuit, you can use it for designing your own applications without needing to make further investments in tools. This product includes through-holes for pin headers that allow access to all MCU signal pins, allowing easy prototyping with a breadboard.

2. Package Contents

- FPB-RA6E1 Fast Prototyping Board (RTK7FPA6E1S00001BE)
- Quick Start Guide (this document)

3. Board Specifications

Item	Specification
Evaluation MCU	Part number: R7FA6E10F2CFP; package: 100-pin LQFP
	On-chip memory: 256 KB ROM, 1 MB RAM, 8 KB data flash memory
Board size	55 mm x 95 mm; thickness: 1.6 mm
Power supply voltage	Vcc: 3.3 V to 5.5 V. MCU operation voltage range 1.6 V to 5.5 V.
Power supply circuit	USB connector: VBUS (5 V input); VBUS is converted to 3.3 V by LDO.
	2-pin external power supply header* ¹
Push switch	Reset switch x 1; user switch x 1
LED	Power indicator: green x 1* ¹ , user: green x 2, debug/power: orange x 1
USB connector	Micro USB Type-B
Pmod™ connector* ¹	Right angle type, 12-pin x 2
Arduino™ connector	6-pin x 1, 8-pin x 2, 10-pin x 1
	The interface is compatible with Arduino™ Uno R3.
MCU header* ¹	50-pin x 2

*¹This part is not mounted.

4. Board Layout

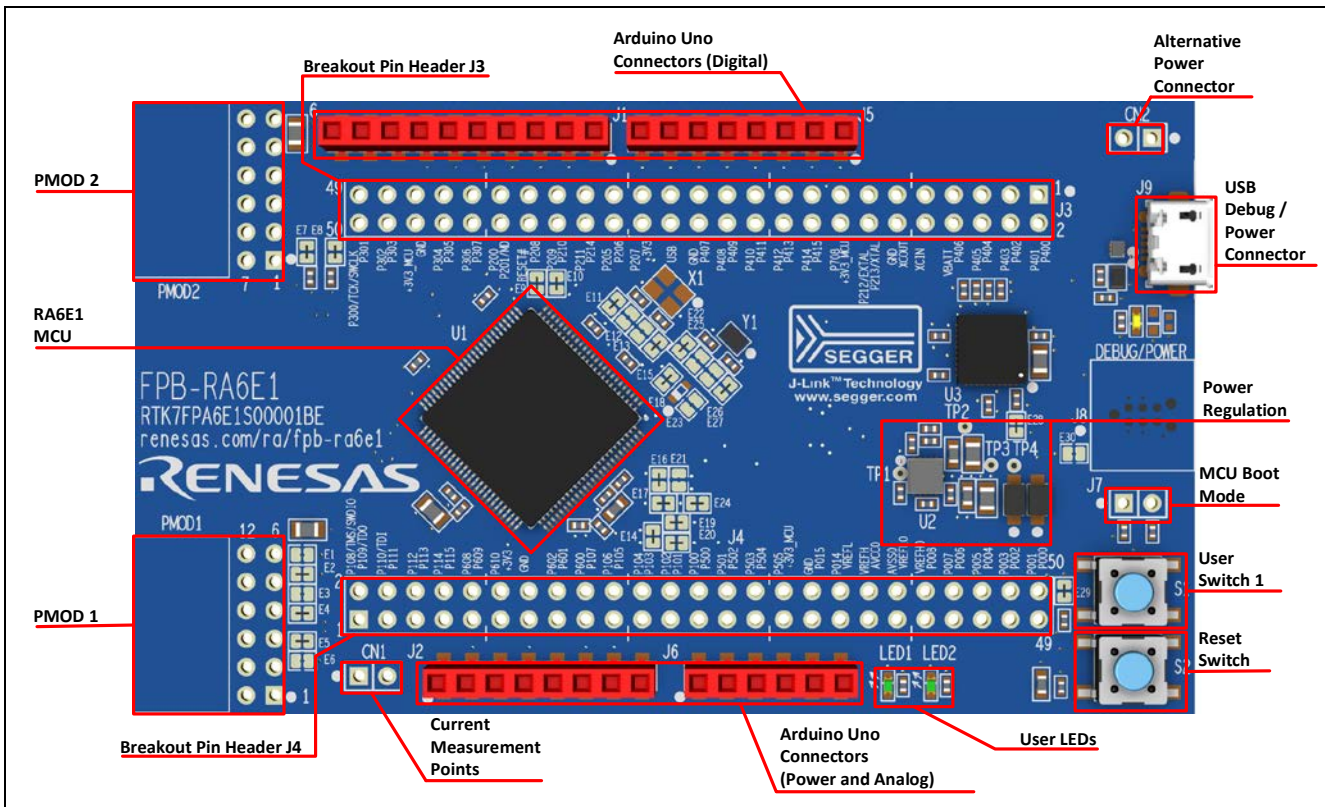

Figure 1. FPB-RA6E1 Board Layout

5. Arduino Interface

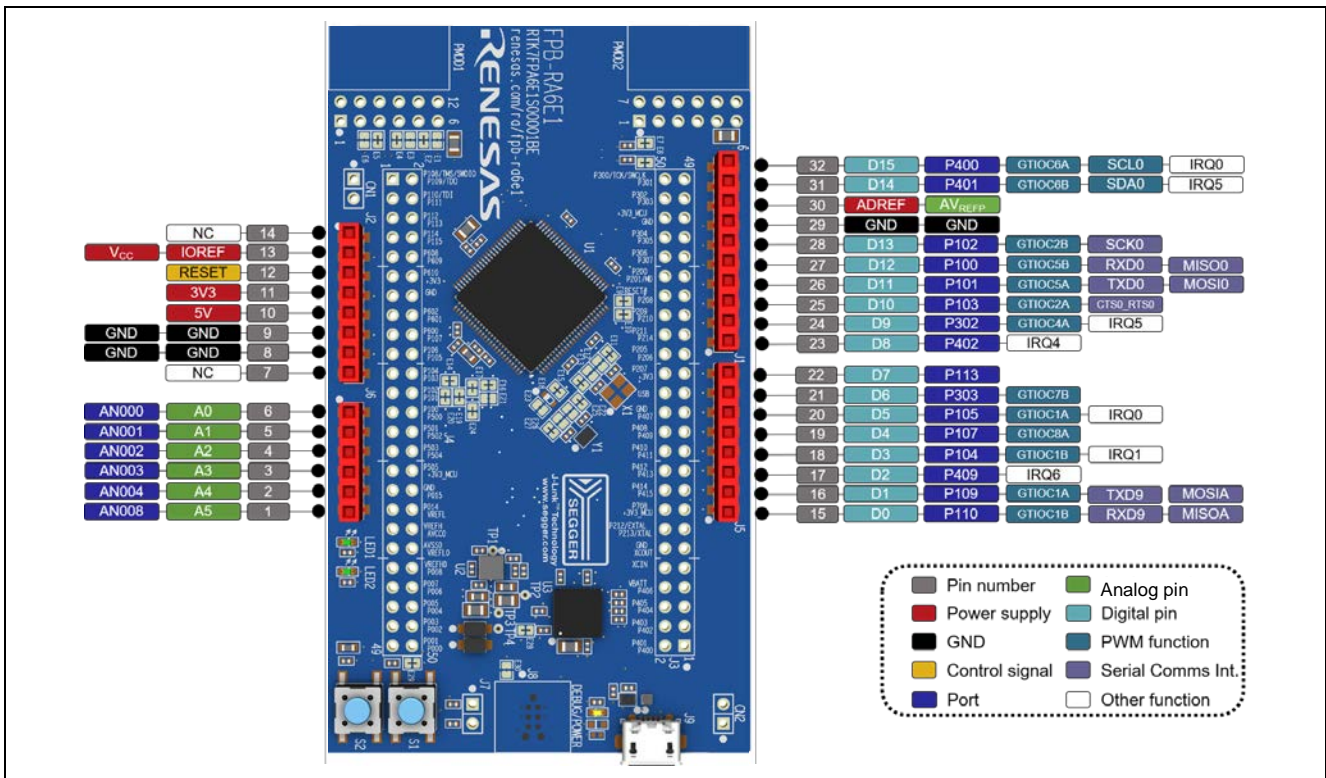

Figure 2. FPB-RA6E1 Arduino Interface

6. Pmod Interface

The FPB-RA6E1 Fast Prototyping Board has two Pmod connectors for the Type 2A interface. Pmod 1 can support Type 6A.

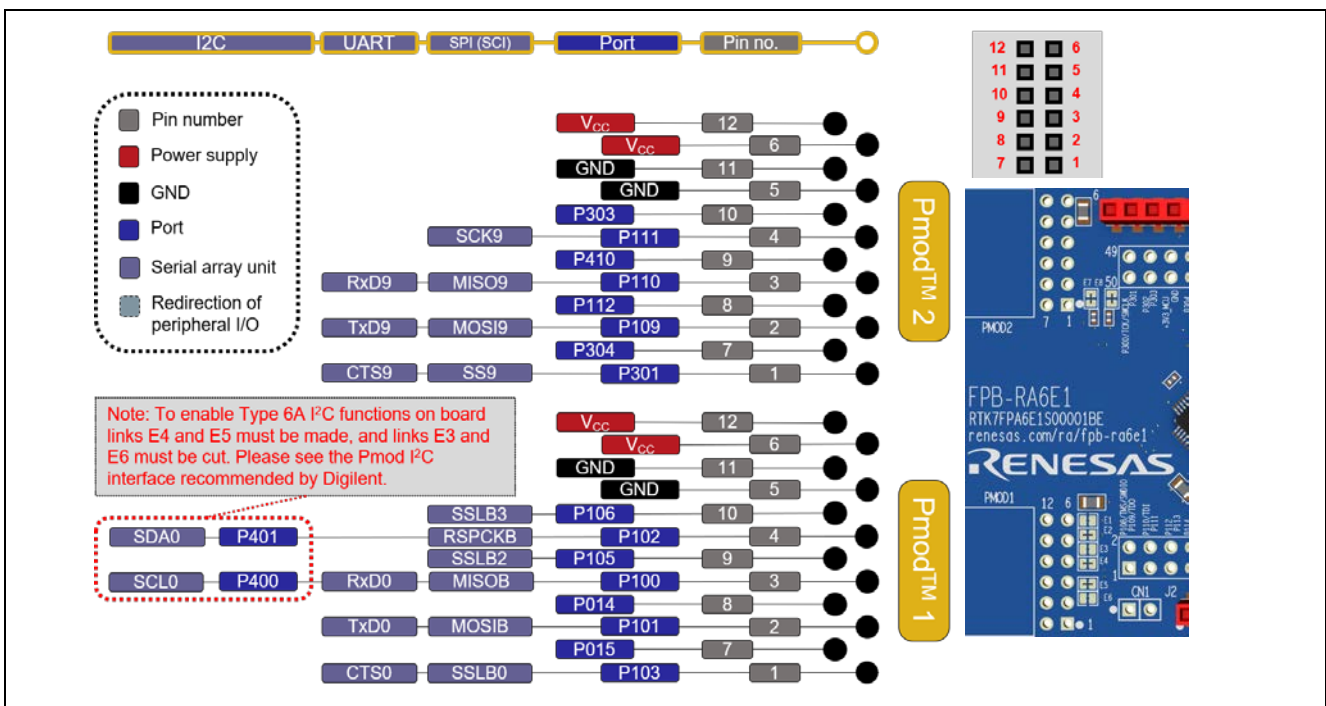

Figure 3. FPB-RA6E1 Pmod Interface

7. Note on Using the Board

Before using this board, download the user's manual from the website at [renesas.com/ra/fpb-ra6e1](https://www.renesas.com/ra/fpb-ra6e1), and check the full specifications.

