

Device Modeling Report

COMPONENTS:
DIODE/ GENERAL PURPOSE RECTIFIER/ STANDARD
PART NUMBER: 1SS412
MANUFACTURER: TOSHIBA



Bee Technologies Inc.

All Rights Reserved Copyright (C) Bee Technologies Inc. 2008

DIODE MODEL PARAMETERS

PSpice model parameter	Model description
IS	Saturation Current
N	Emission Coefficient
RS	Series Resistance
IKF	High-injection Knee Current
CJO	Zero-bias Junction Capacitance
M	Junction Grading Coefficient
VJ	Junction Potential
ISR	Recombination Current Saturation Value
BV	Reverse Breakdown Voltage(a positive value)
IBV	Reverse Breakdown Current(a positive value)
TT	Transit Time
EG	Energy-band Gap

Forward Current Characteristic

Circuit Simulation Result

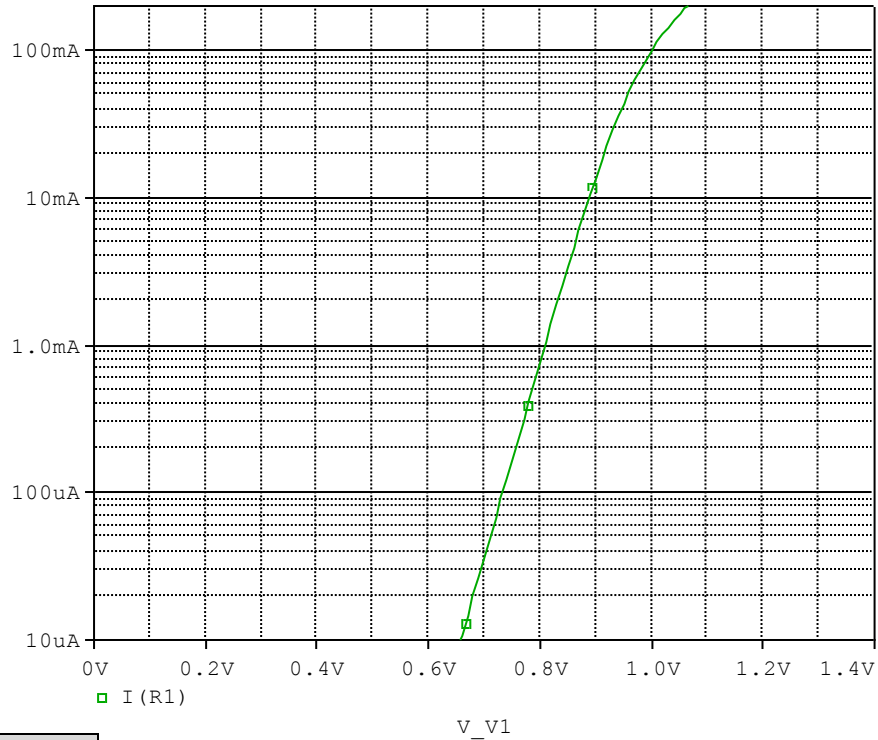

Evaluation Circuit

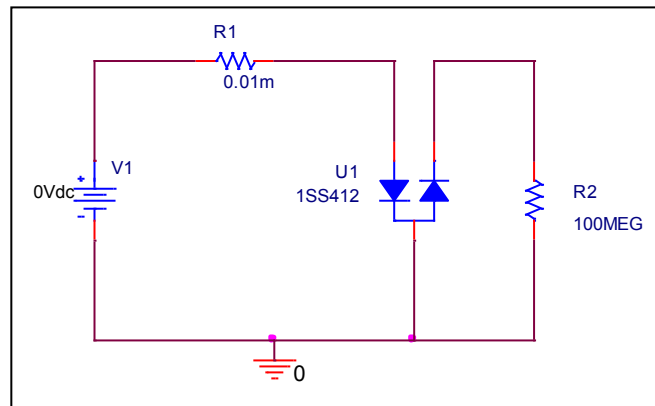

Comparison Graph

Circuit Simulation Result

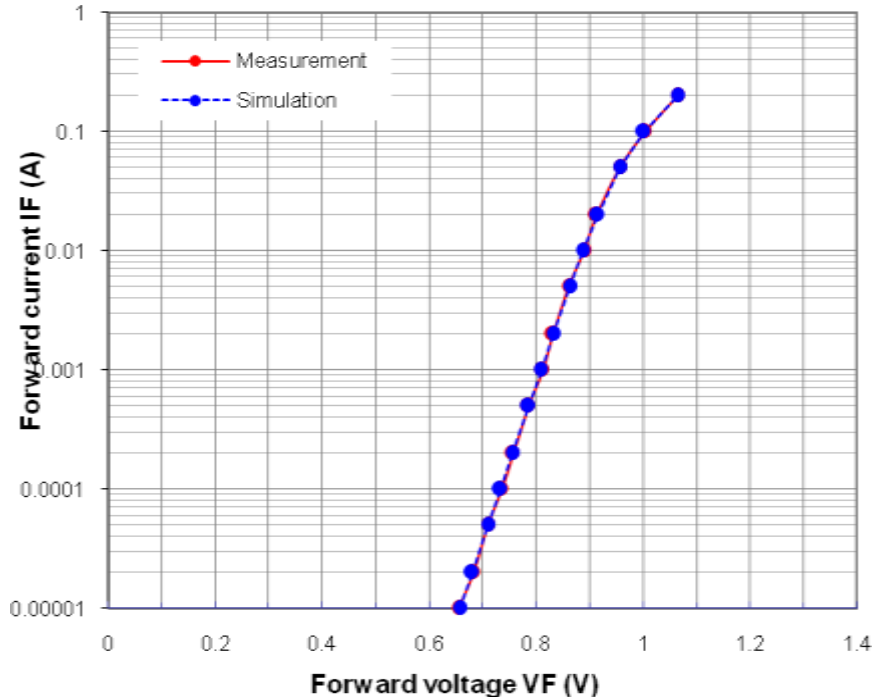

Simulation Result

Ifwd (A)	Vfwd (V)		%Error
	Measurement	Simulation	
0.00001	0.655	0.658	0.40
0.00002	0.682	0.680	-0.22
0.00005	0.710	0.710	0.00
0.0001	0.735	0.733	-0.29
0.0002	0.757	0.756	-0.19
0.0005	0.785	0.786	0.08
0.001	0.812	0.809	-0.41
0.002	0.831	0.832	0.09
0.005	0.861	0.863	0.22
0.01	0.889	0.888	-0.15
0.02	0.912	0.914	0.27
0.05	0.957	0.957	0.00
0.1	1.003	1.001	-0.24
0.2	1.064	1.065	0.08

Capacitance Characteristic

Circuit Simulation Result

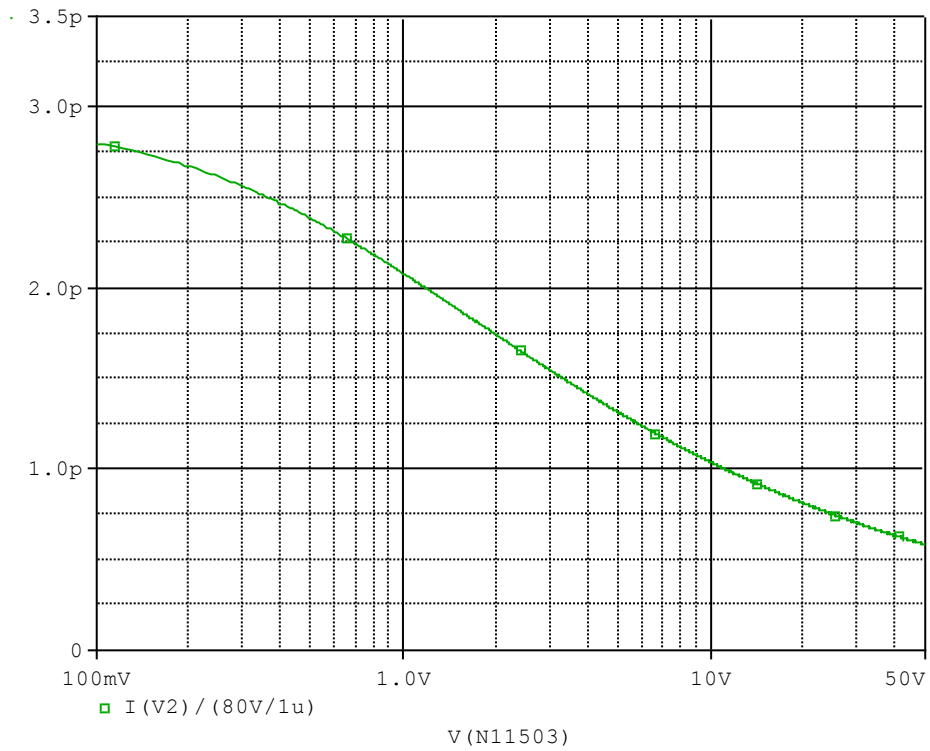

Evaluation Circuit

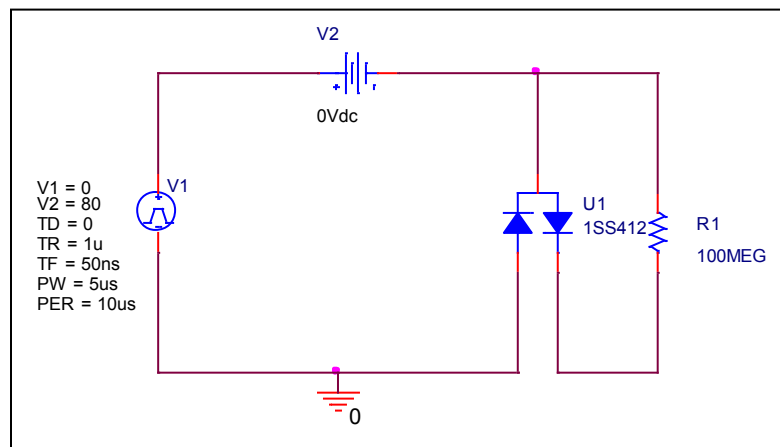

Comparison Graph

Circuit Simulation Result

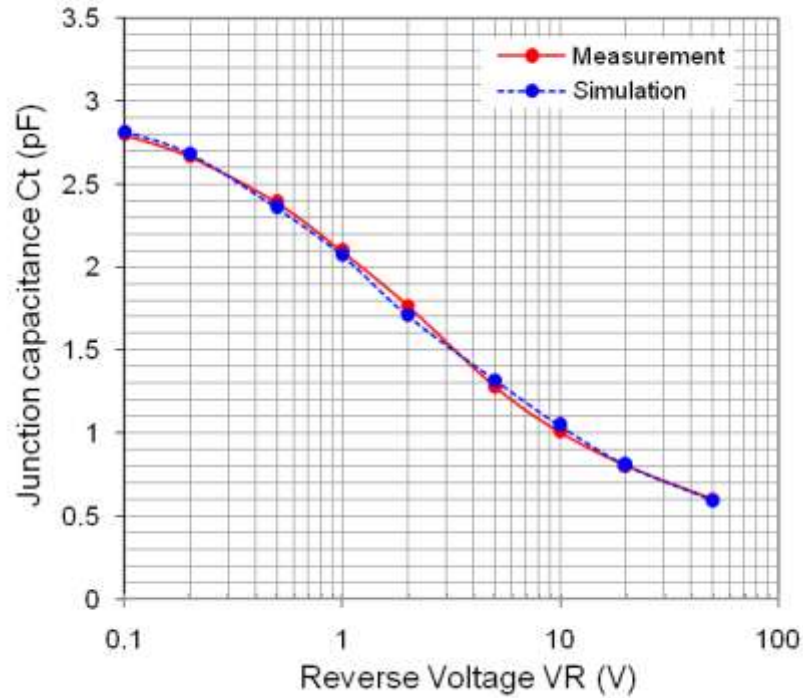

Simulation Result

Vrev (V)	Ct (pF)		%Error
	Measurement	Simulation	
0.1	2.797	2.802	0.16
0.2	2.664	2.670	0.23
0.5	2.387	2.381	-0.26
1	2.094	2.080	-0.69
2	1.767	1.744	-1.32
5	1.280	1.314	2.66
10	1.008	1.039	3.08
20	0.802	0.814	1.50
50	0.603	0.583	-3.32

Reverse Recovery Characteristic

Circuit Simulation Result

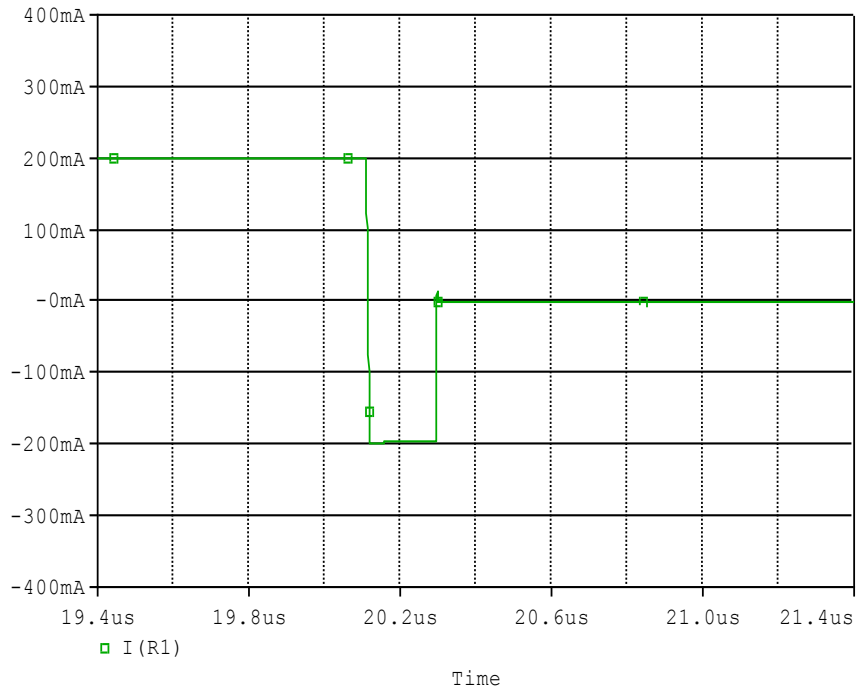

Evaluation Circuit

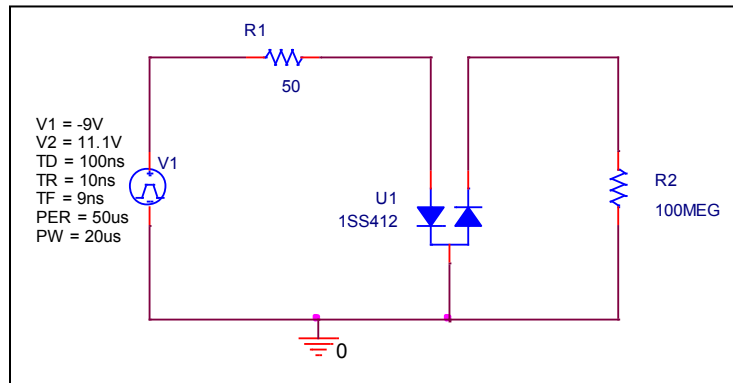

Compare Measurement vs. Simulation

		Measurement	Simulation	%Error
trj	ns	92.00	91.379	-0.67

Reverse Recovery Characteristic

Reference

Measurement

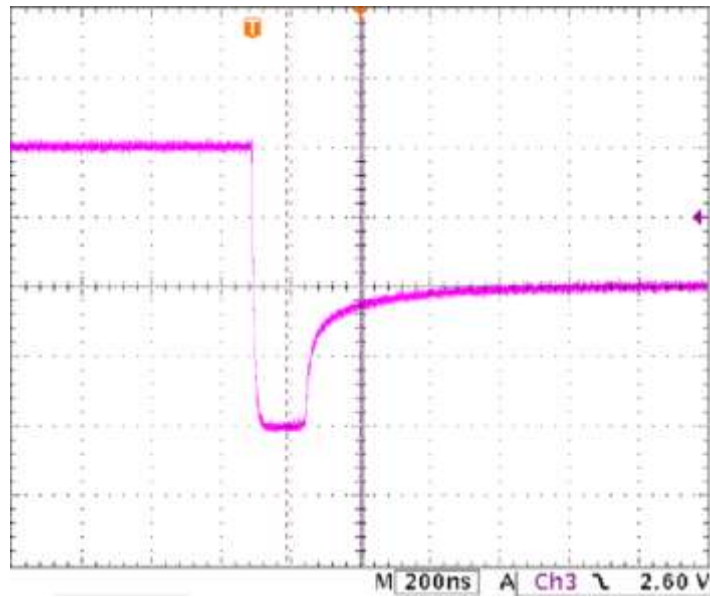

$T_{rj} = 92(\text{ns})$
 $T_{rb} = 220(\text{ns})$
Conditions: $I_{fwd} = 0.2\text{A}$, $I_{rev} = 0.2\text{A}$, $R_I = 50$

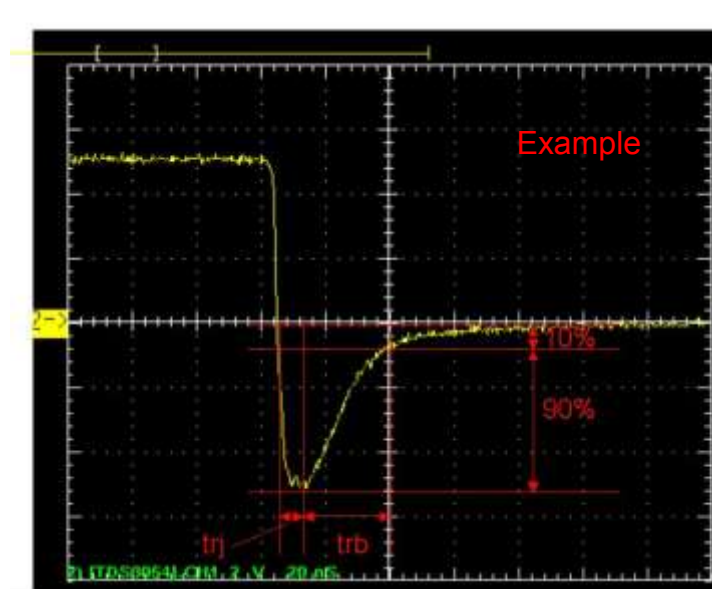

Relation between t_{rj} and t_{rb}