

Device Modeling Report

COMPONENTS:
DIODE/ GENERAL PURPOSE RECTIFIER/ PROFESSIONAL
PART NUMBER: 5GLZ47A
MANUFACTURER: TOSHIBA
REMARK: TC=110C



Bee Technologies Inc.

PSpice model parameter	Model description
IS	Saturation Current
N	Emission Coefficient
RS	Series Resistance
IKF	High-injection Knee Current
CJO	Zero-bias Junction Capacitance
M	Junction Grading Coefficient
VJ	Junction Potential
ISR	Recombination Current Saturation Value
BV	Reverse Breakdown Voltage(a positive value)
IBV	Reverse Breakdown Current(a positive value)
TT	Transit Time
EG	Energy-band Gap

Forward Current Characteristic

Reference

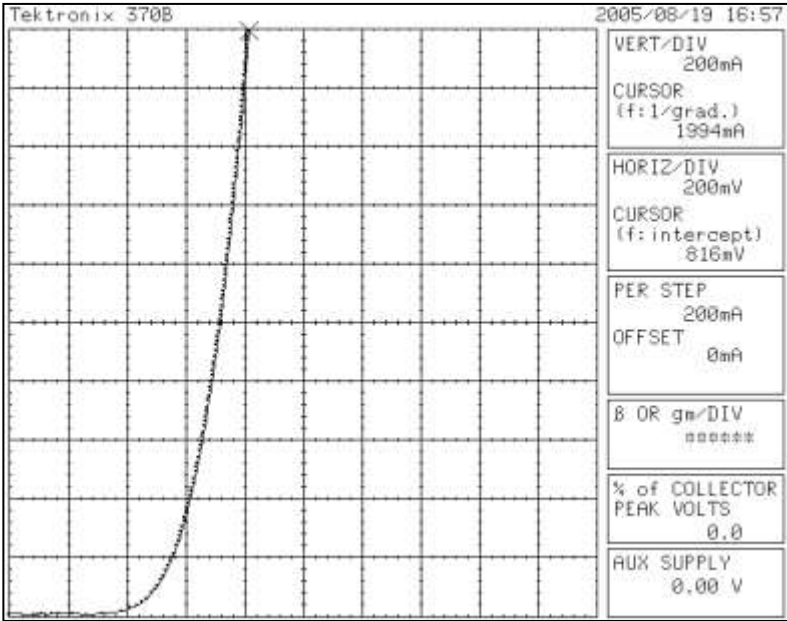

Forward Current Characteristic

Circuit Simulation Result

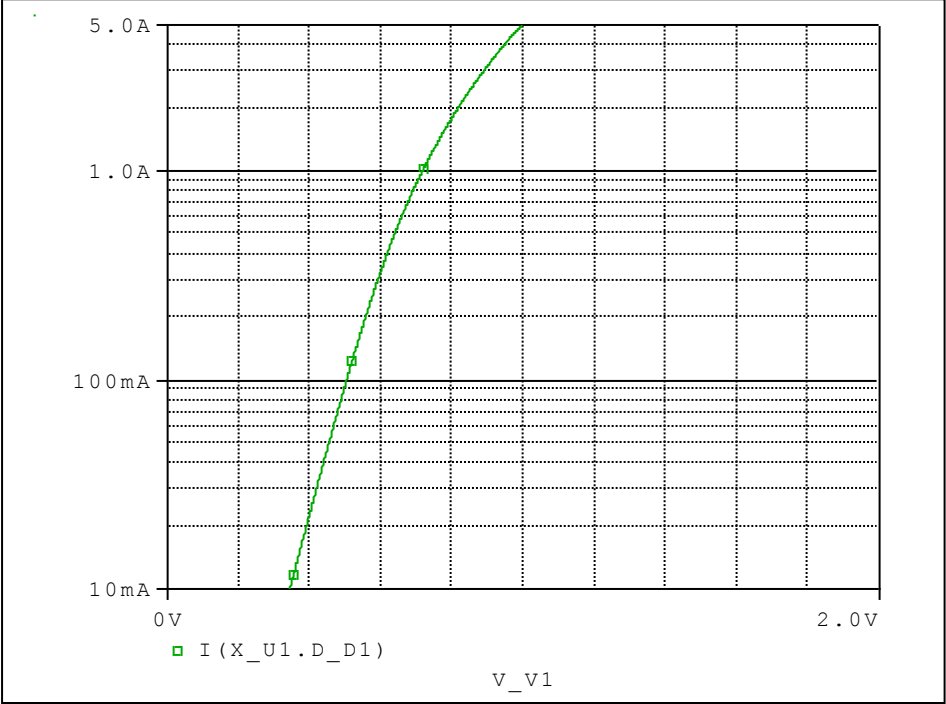

Evaluation Circuit

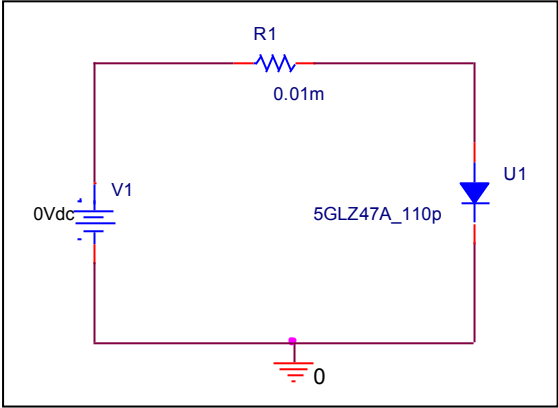

Comparison Graph

Circuit Simulation Result

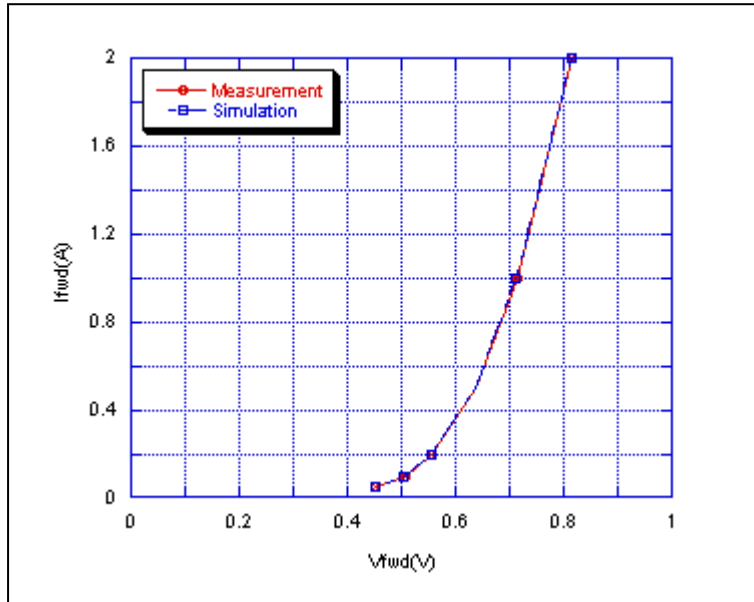

Simulation Result

Ifwd(A)	Vfwd(V) Measurement	Vfwd(V) Simulation	%Error
0.05	0.452	0.451	0.221
0.1	0.506	0.503	0.593
0.2	0.554	0.556	-0.361
0.5	0.638	0.637	0.157
1	0.716	0.712	0.559
2	0.816	0.815	0.123

Capacitance Characteristic

Circuit Simulation Result

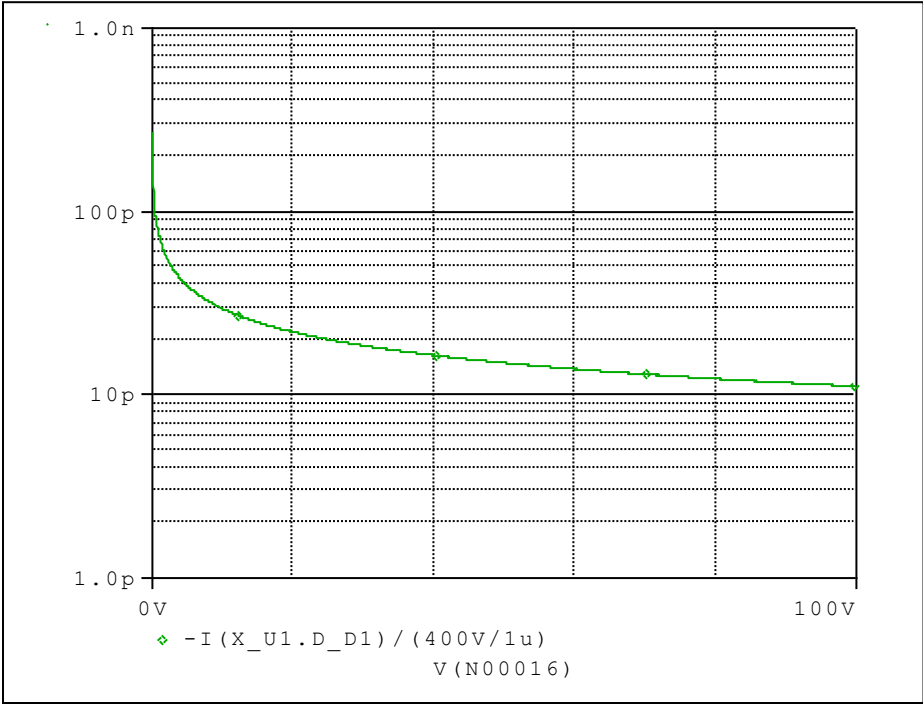

Evaluation Circuit

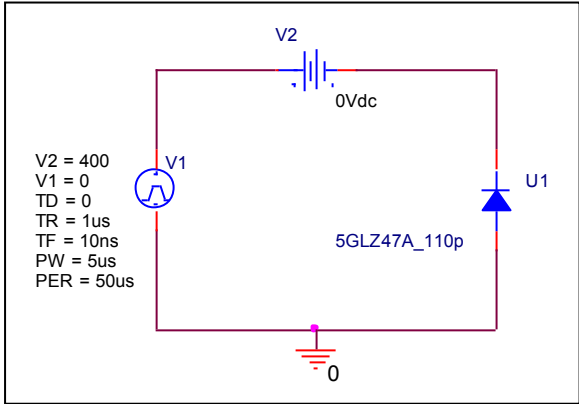

Comparison Graph

Circuit Simulation Result

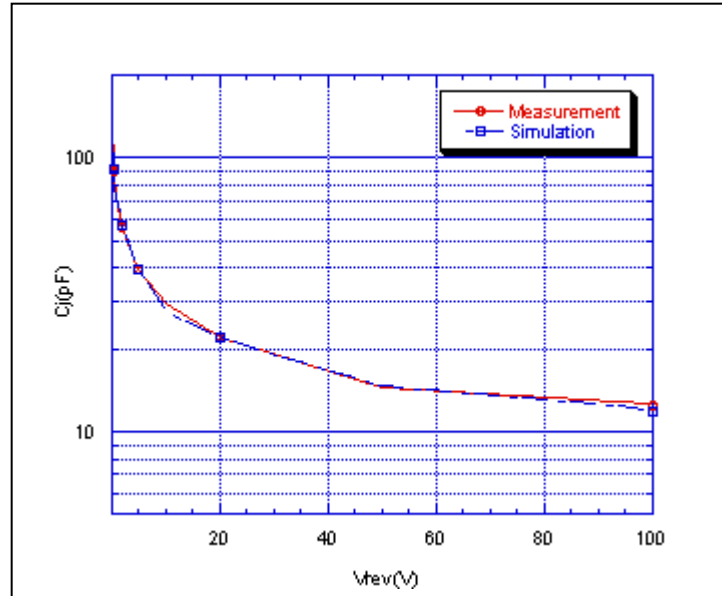

Simulation Result

Vrev(V)	Cj(pF) Measurement	Cj(pF) Simulation	%Error
0	143.500	143.500	0.000
0.5	89.800	90.200	-0.445
1	72.100	72.600	-0.693
2	55.600	56.400	-1.439
5	38.900	39.000	-0.257
10	29.300	29.100	0.683
20	22.000	21.800	0.909
50	14.600	14.900	-2.055
100	12.500	11.880	4.960

Reverse Recovery Characteristic

Circuit Simulation Result

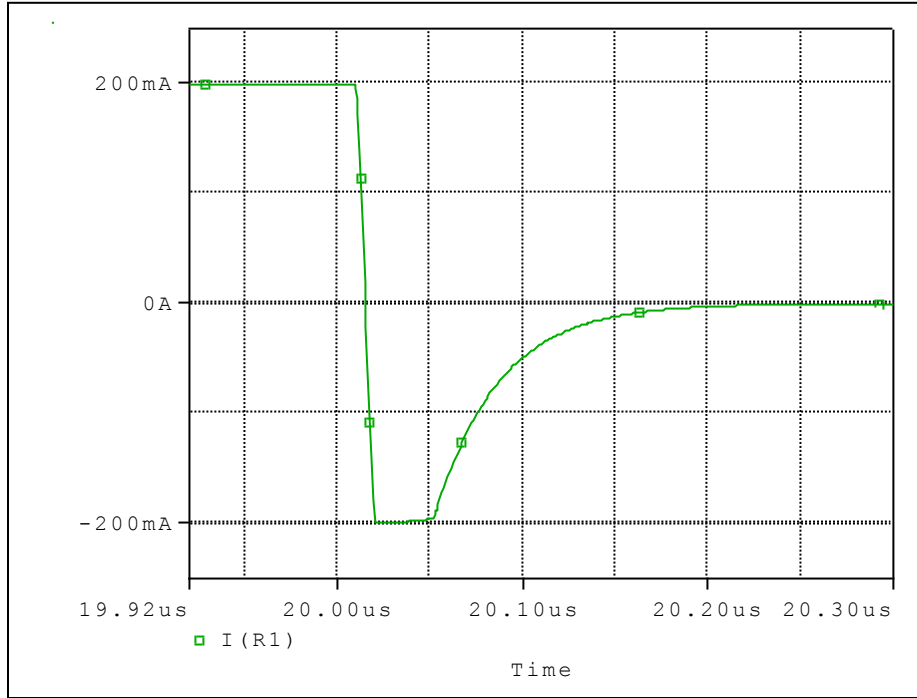

Evaluation Circuit

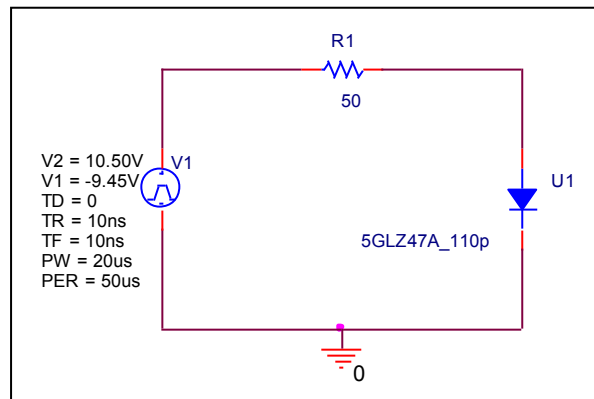

Compare Measurement vs. Simulation

	Measurement		Simulation		%Error
trj	36.00	ns	36.09	ns	-0.25
trb	80.00	ns	79.86	ns	0.17

Reverse Recovery Characteristic

Reference

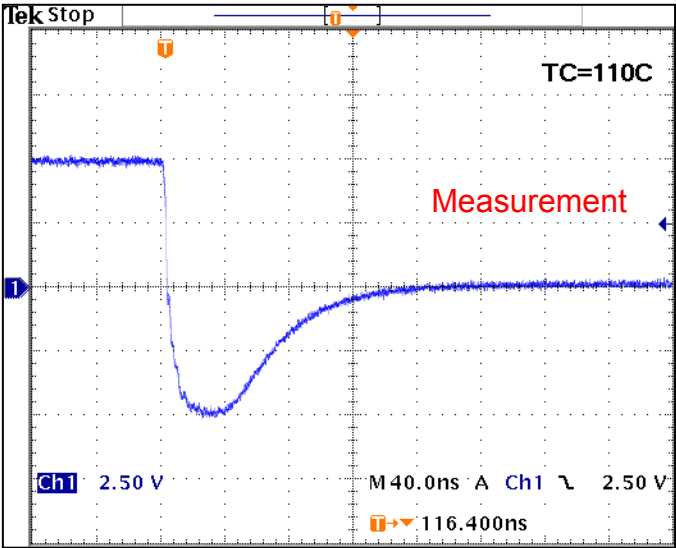

Trj =36 (ns)
Trb= 80 (ns)
Conditions: Ifwd=Irev=0.2(A), RI=50

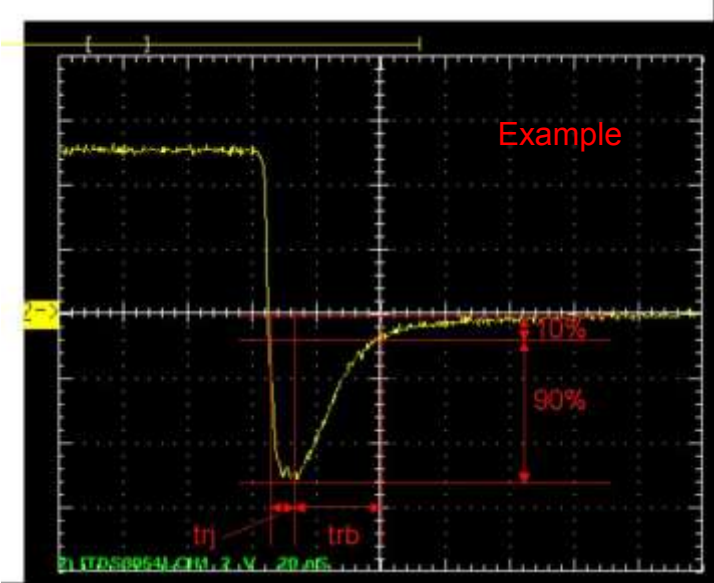

Relation between trj and trb