

Device Modeling Report

COMPONENTS:
DIODE/GENERAL PURPOSE RECTIFIER/ STANDARD
PART NUMBER: UF5402
MANUFACTURER: VISHAY
REMARK: TC=25C



Bee Technologies Inc.

Pspice model parameter	Model description
IS	Saturation Current
N	Emission Coefficient
RS	Series Resistance
IKF	High-injection Knee Current
CJO	Zero-bias Junction Capacitance
M	Junction Grading Coefficient
VJ	Junction Potential
ISR	Recombination Current Saturation Value
BV	Reverse Breakdown Voltage(a positive value)
IBV	Reverse Breakdown Current(a positive value)
TT	Transit Time

Forward Current Characteristic

Circuit simulation result

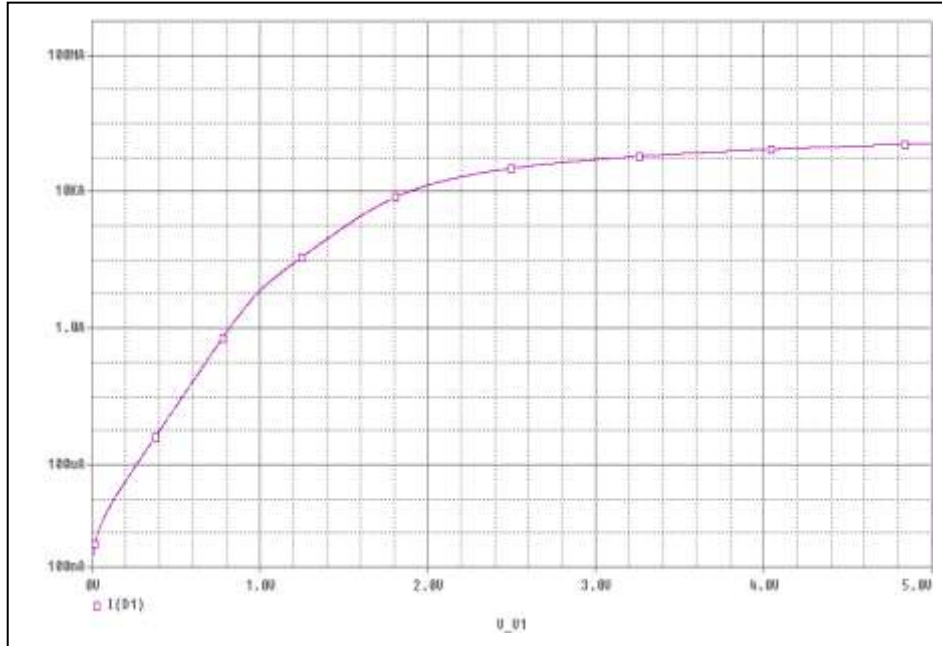

Evaluation circuit

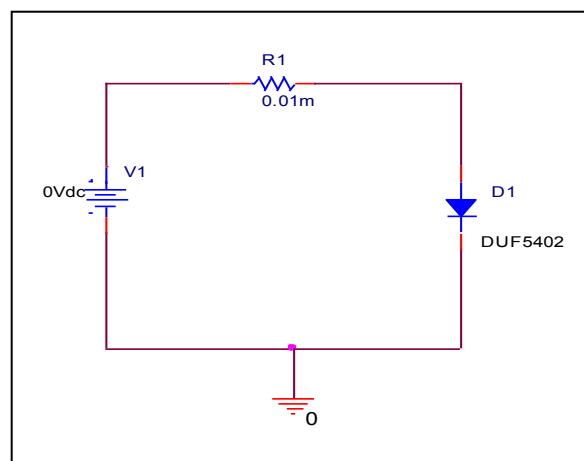

Comparison graph

Circuit simulation result

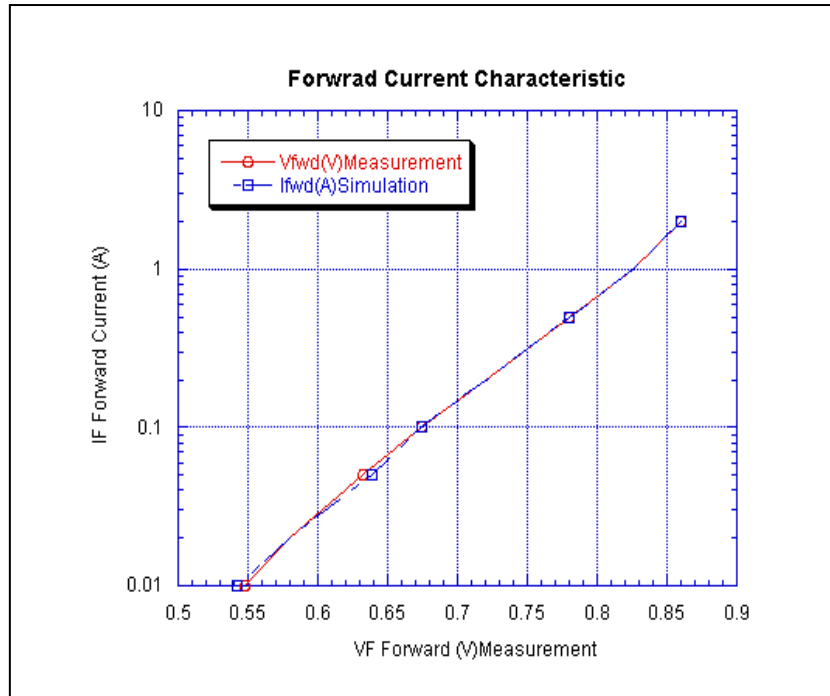

Simulation Result

IFwd (A)	VFwd (V)		Error (%)
	Measurement	Simulation	
0.01	0.548	0.542	1.09
0.02	0.580	0.580	0.00
0.05	0.632	0.639	-1.11
0.1	0.674	0.673	0.07
0.2	0.720	0.721	-0.15
0.5	0.780	0.775	0.64
1	0.826	0.824	0.24
2	0.860	0.858	0.23

Junction Capacitance Characteristic

Circuit simulation result

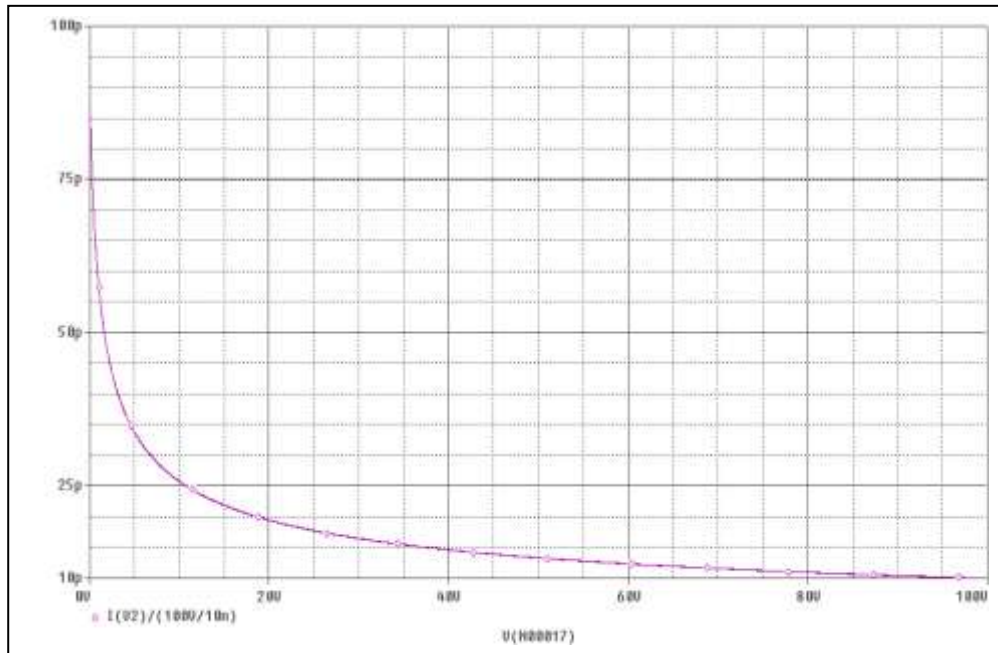

Evaluation circuit

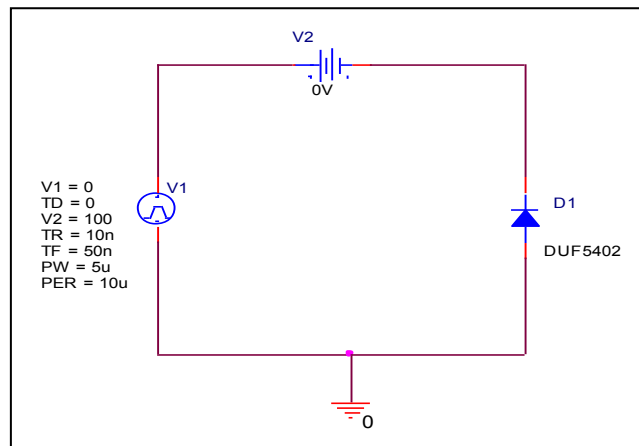

Comparison graph

Circuit simulation result

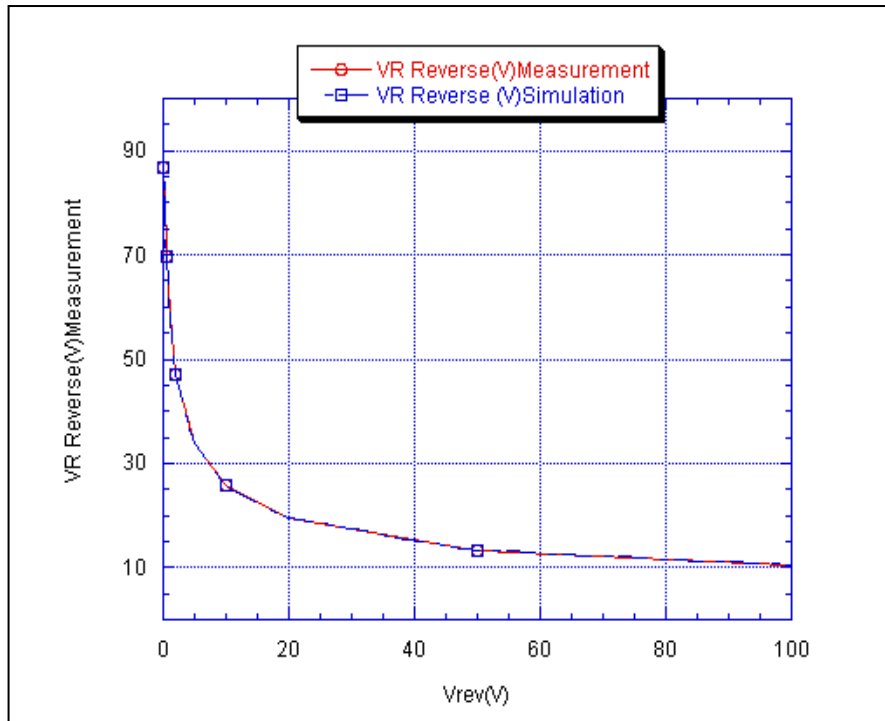

Circuit simulation result

Vrev(V)	Cj(pF)		Error (%)
	Measurement	Simulation	
0.1	93.649	94.118	-0.50
0.2	87.910	87.843	0.08
0.5	74.830	74.902	-0.10
1	62.942	61.961	1.56
2	50.297	49.800	0.99
5	35.682	35.686	-0.01
10	26.867	26.863	0.01
20	20.104	20.200	-0.48
50	13.694	13.661	0.24

Reverse Recovery Characteristic

Circuit simulation result

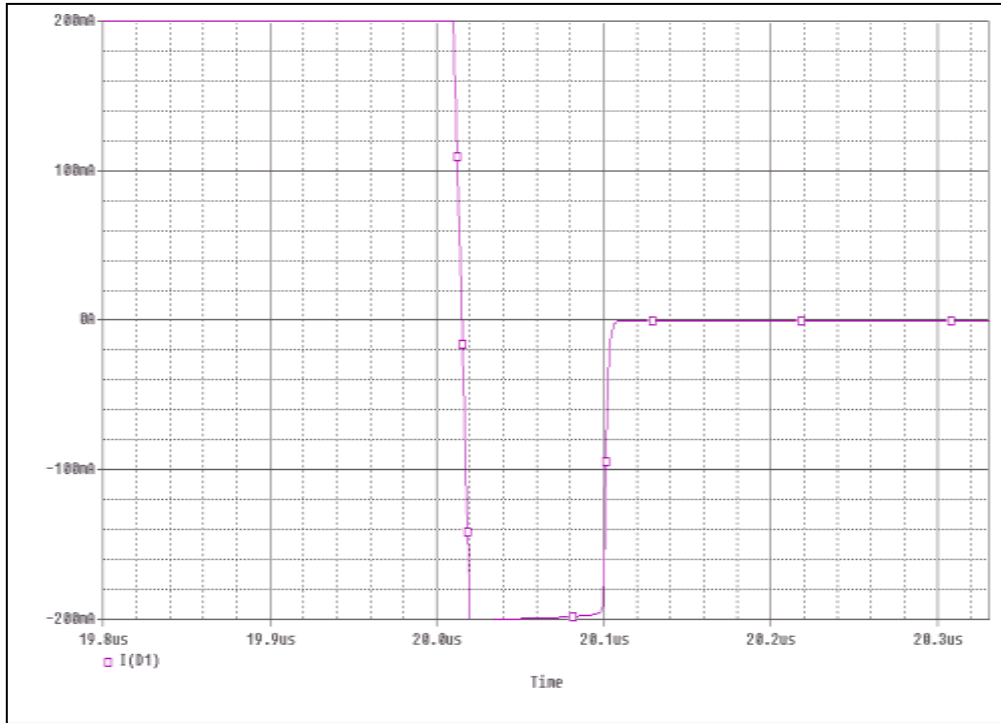

Evaluation circuit

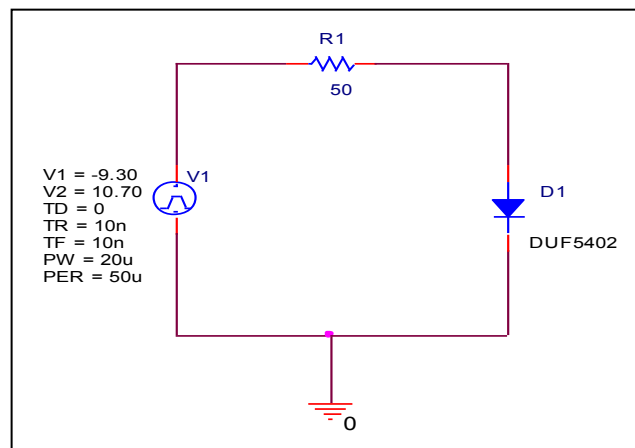

Measurement VS . Simulation

	Measurement		Simulation		%Error
trr	88.8	ns	88.0	ns	0.90

Reverse Recovery Characteristic

Reference

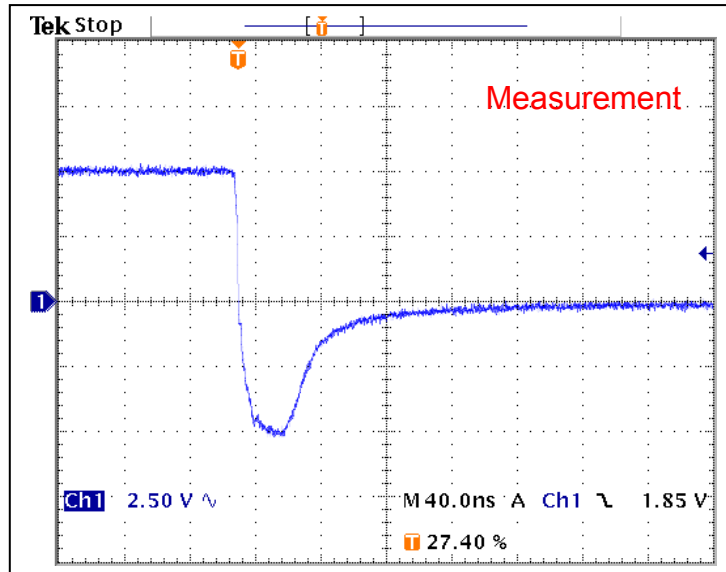

$trj=25.6(ns)$
 $trb=63.2(ns)$
Conditions: $I_{fwd}=I_{rev}=0.2(A)$, $R_I=50$

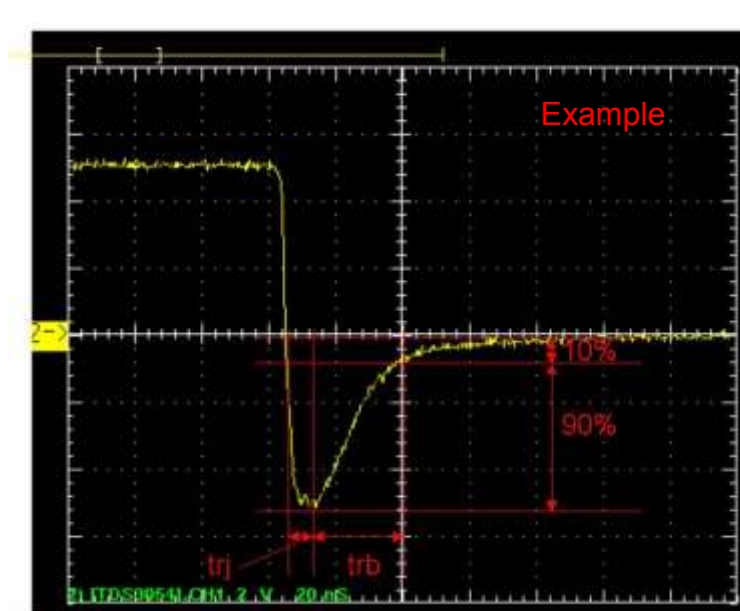

Relation between trj and trb