

# Device Modeling Report

COMPONENTS:  
DIODE/ SCHOTTKY RECTIFIER/ PROFESSIONAL  
PART NUMBER: 30WQ04FN  
MANUFACTURER: INTERNATIONAL RECTIFIER



**Bee Technologies Inc.**

PSpice model parameter	Model description
IS	Saturation Current
N	Emission Coefficient
RS	Series Resistance
IKF	High-injection Knee Current
CJO	Zero-bias Junction Capacitance
M	Junction Grading Coefficient
VJ	Junction Potential
ISR	Recombination Current Saturation Value
BV	Reverse Breakdown Voltage(a positive value)
IBV	Reverse Breakdown Current(a positive value)
TT	Transit Time
EG	Energy-band Gap

# Forward Current Characteristic

## Circuit Simulation Result

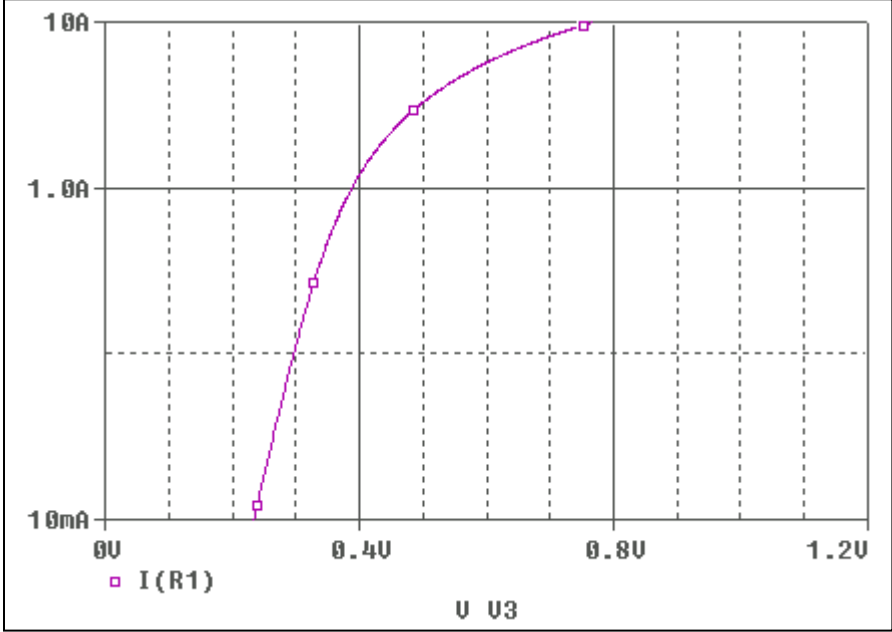

## Evaluation Circuit

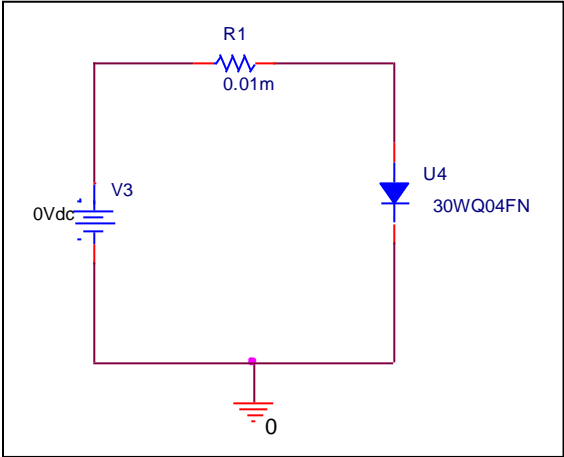

## Comparison Graph

### Circuit Simulation Result

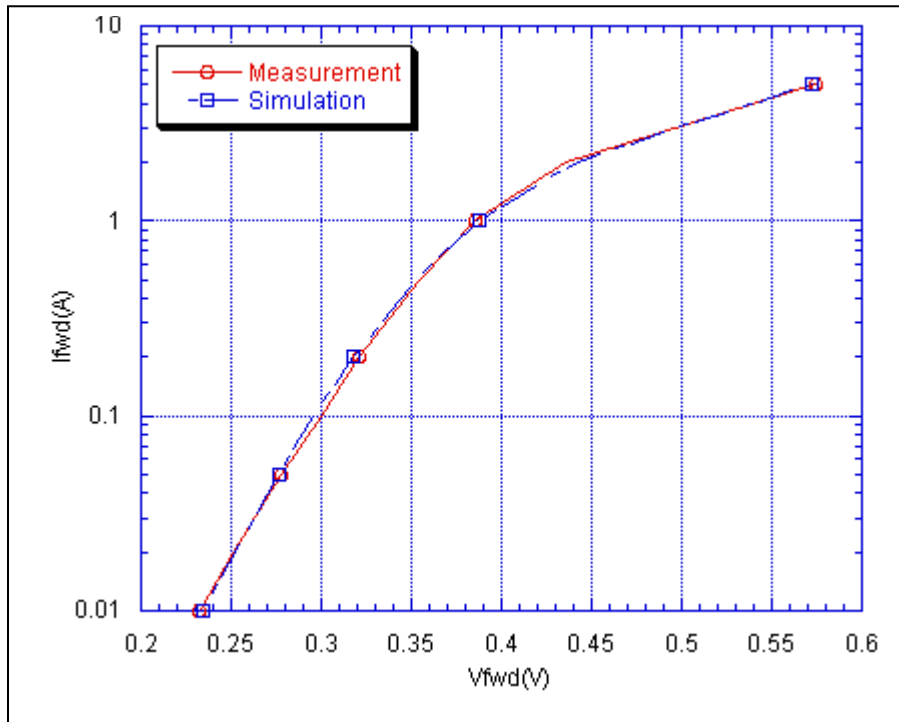

### Simulation Result

$I_{fwd}$ (A)	$V_{fwd}$ (V) Measurement	$V_{fwd}$ (V) Simulation	%Error
0.01	0.232	0.234	0.85
0.02	0.251	0.252	0.40
0.05	0.278	0.277	-0.36
0.1	0.300	0.296	-1.35
0.2	0.321	0.318	-0.94
0.5	0.355	0.352	-0.85
1	0.386	0.388	0.52
2	0.436	0.442	1.36
5	0.575	0.572	-0.52

# Junction Capacitance Characteristic

## Circuit Simulation Result

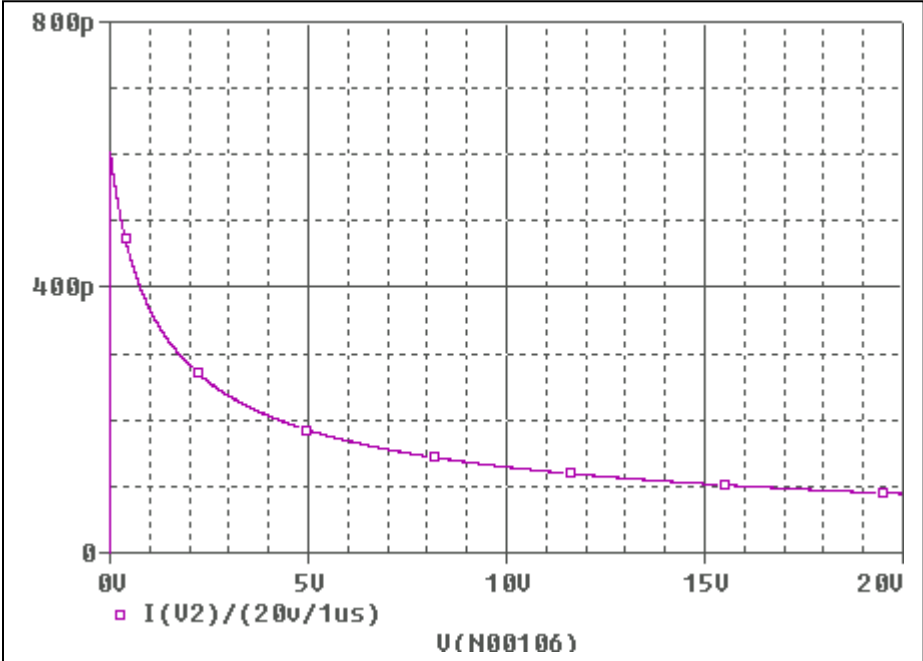

## Evaluation Circuit

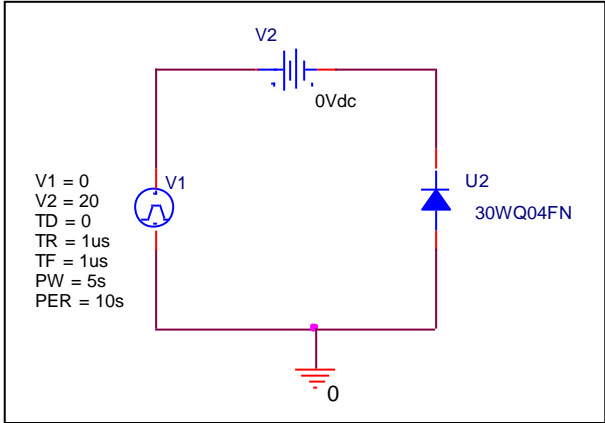

## Comparison Graph

### Circuit Simulation Result

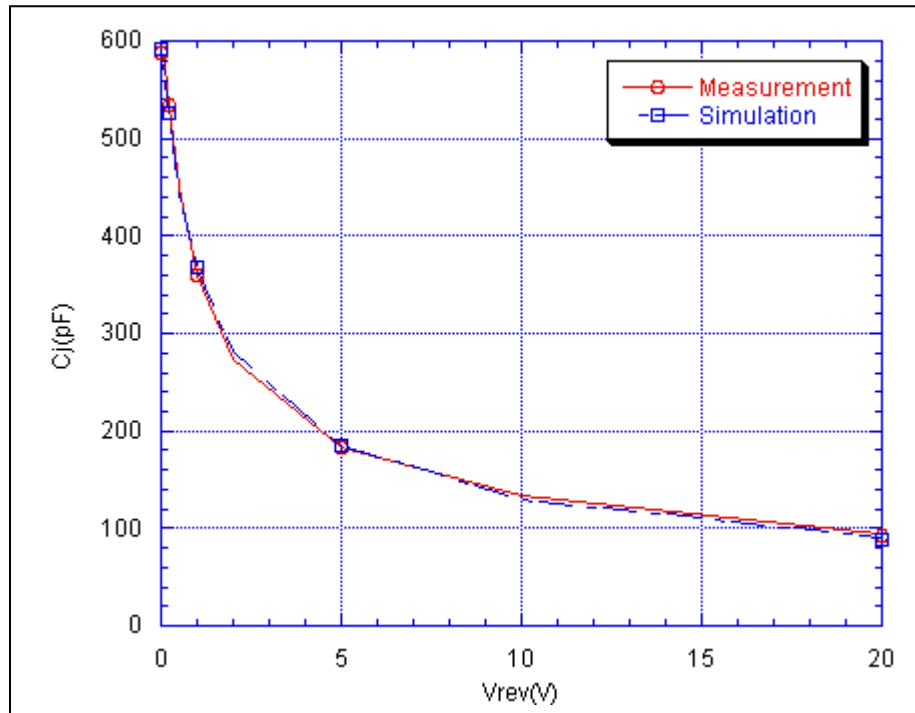

### Simulation Result

Vrev(V)	Cj(pF) Measurement	Cj(pF) Simulation	%Error
0	588.14	592.56	0.75
0.1	576.45	561.47	-2.67
0.2	534.96	525.87	-1.73
0.5	449.97	447.09	-0.65
1	359.15	365.63	1.77
2	274.14	282.57	2.98
5	182.97	184.92	1.06
10	132.82	129.32	-2.71
20	91.66	88.77	-3.26

# Reverse Characteristic

## Circuit Simulation Result

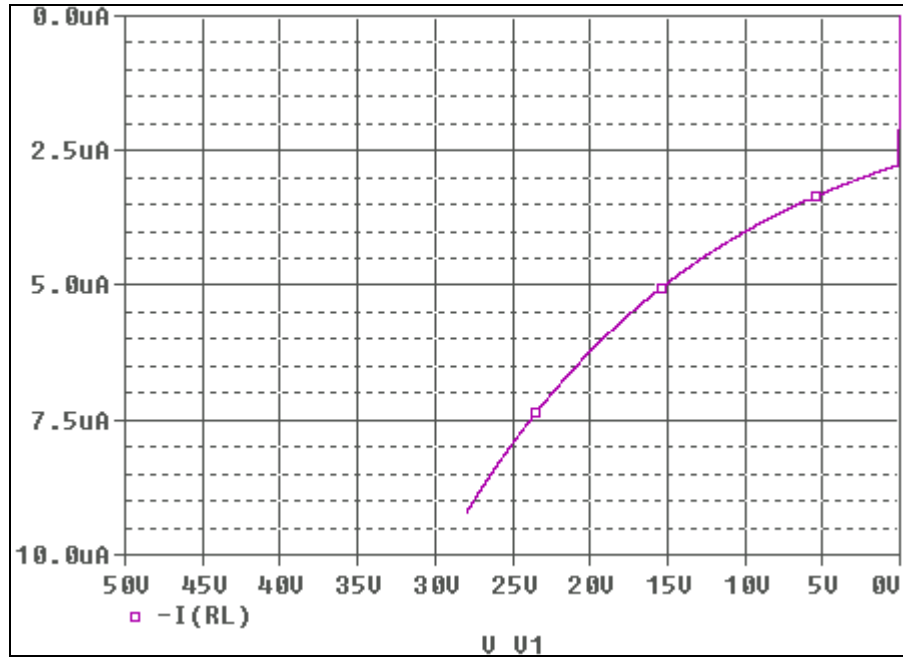

## Evaluation Circuit

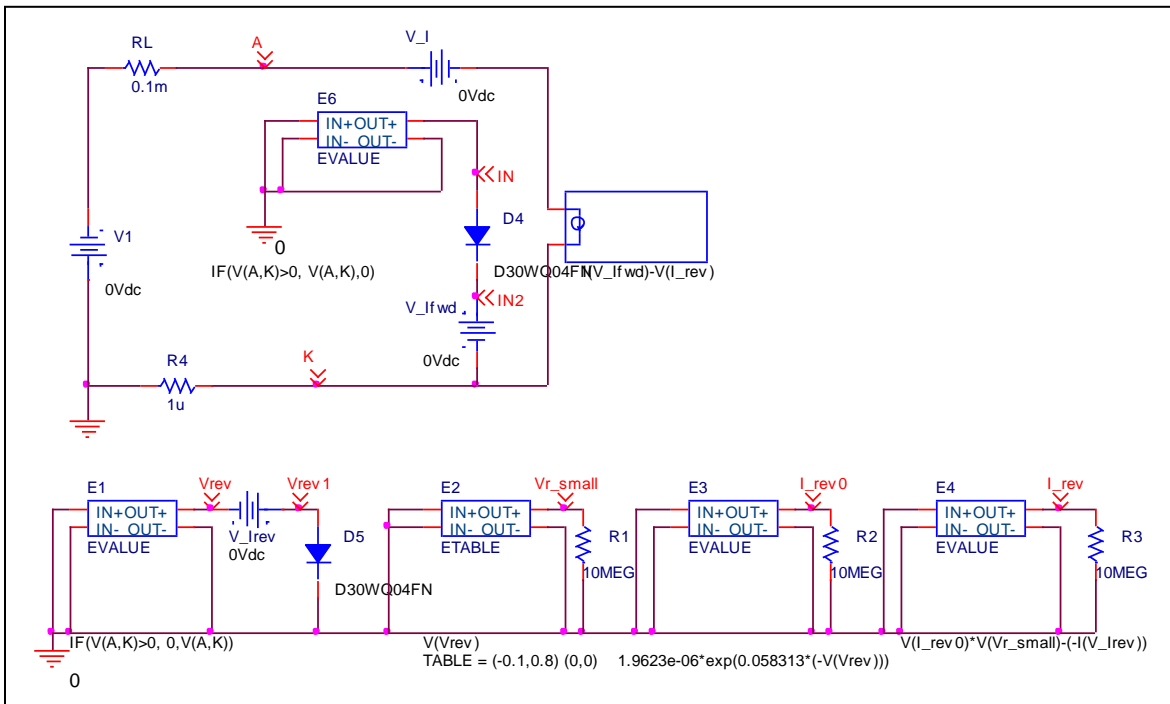

# Comparison Graph

## Circuit Simulation Result

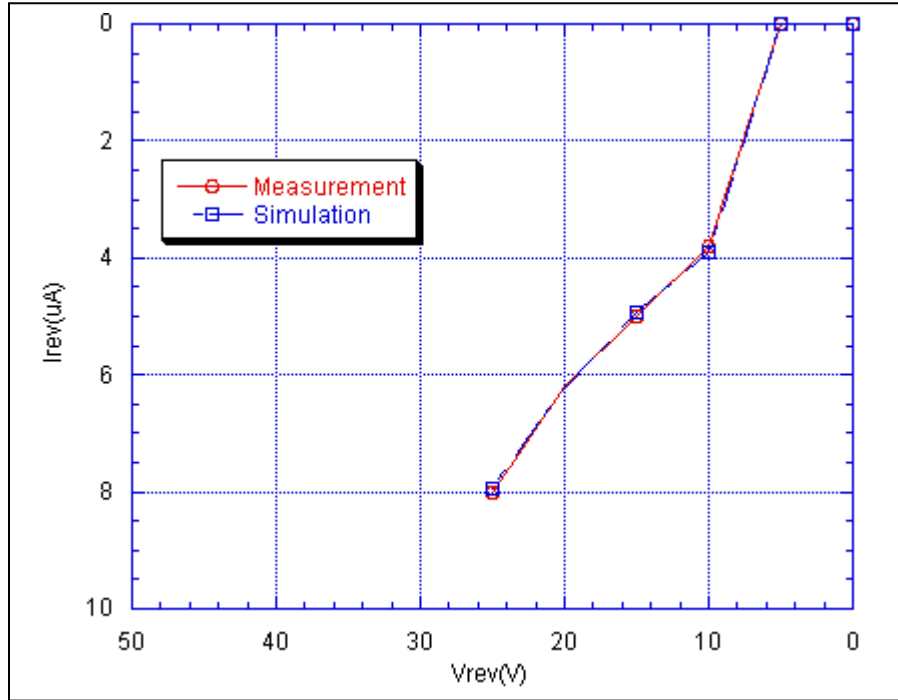

## Simulation Result

Vrev(V)	Irev(uA) Measurement	Irev(uA) Simulation	%Error
10	3.80	3.90	2.56
15	5.00	4.95	-1.01
20	6.20	6.23	0.48
25	8.00	7.93	-0.88



# Reverse Characteristic

# Reference

