

Device Modeling Report

COMPONENTS: CAPACITOR/ ELECTROLYTIC
PART NUMBER: UUG1E332MNR1M5
MANUFACTURER: Nichicon
THERMAL: Ta= 25C (degree)



Bee Technologies Inc.

Theory: Auto Balancing Bridge Method

Optimization of Simulation

Range of adjustment Frequency: 100 Hz to 100M(Hz)

Frequency vs. $|Z|$ and Frequency vs. θ_z Characteristic

Attention)

Please use SPICE MODEL within the range from 100Hz to 100M(Hz)

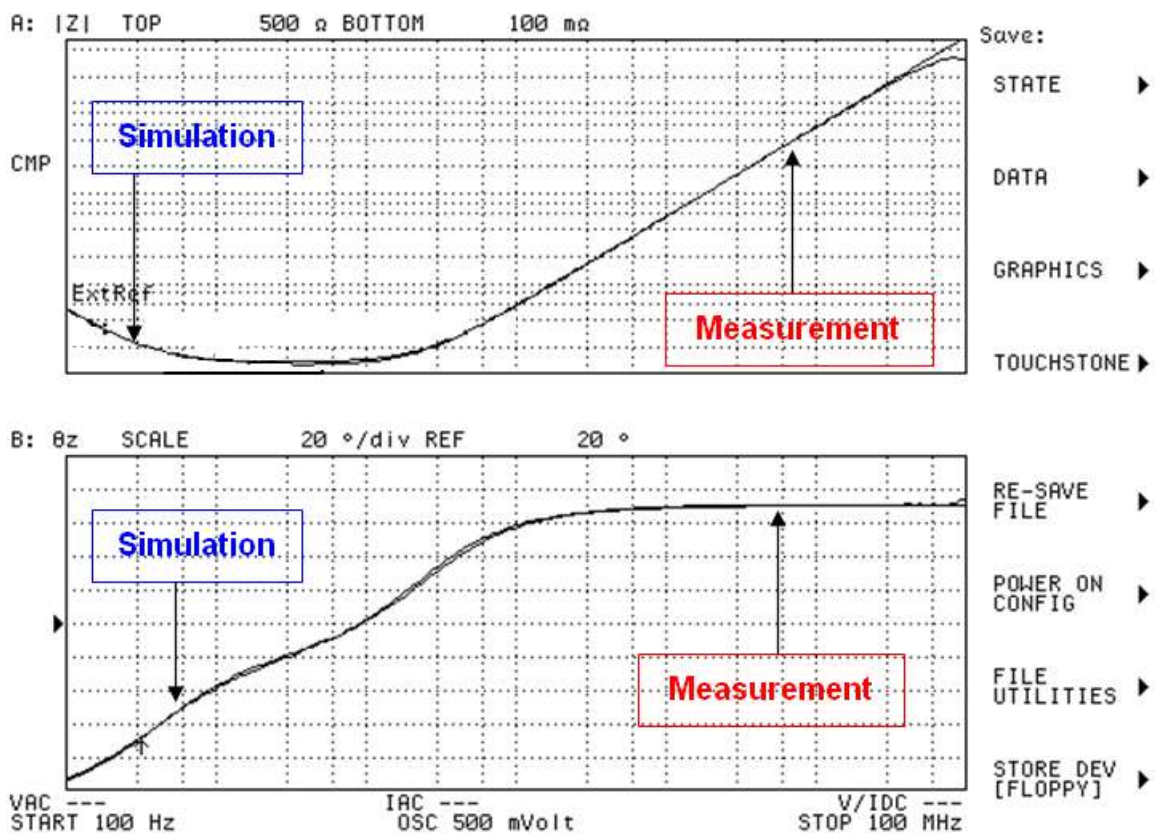

	Measurement	
R1		
C1		
L1		

Equivalent circuit

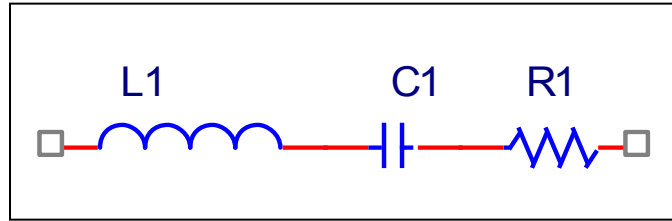

Frequency vs. IZI Characteristic

Circuit Simulation result

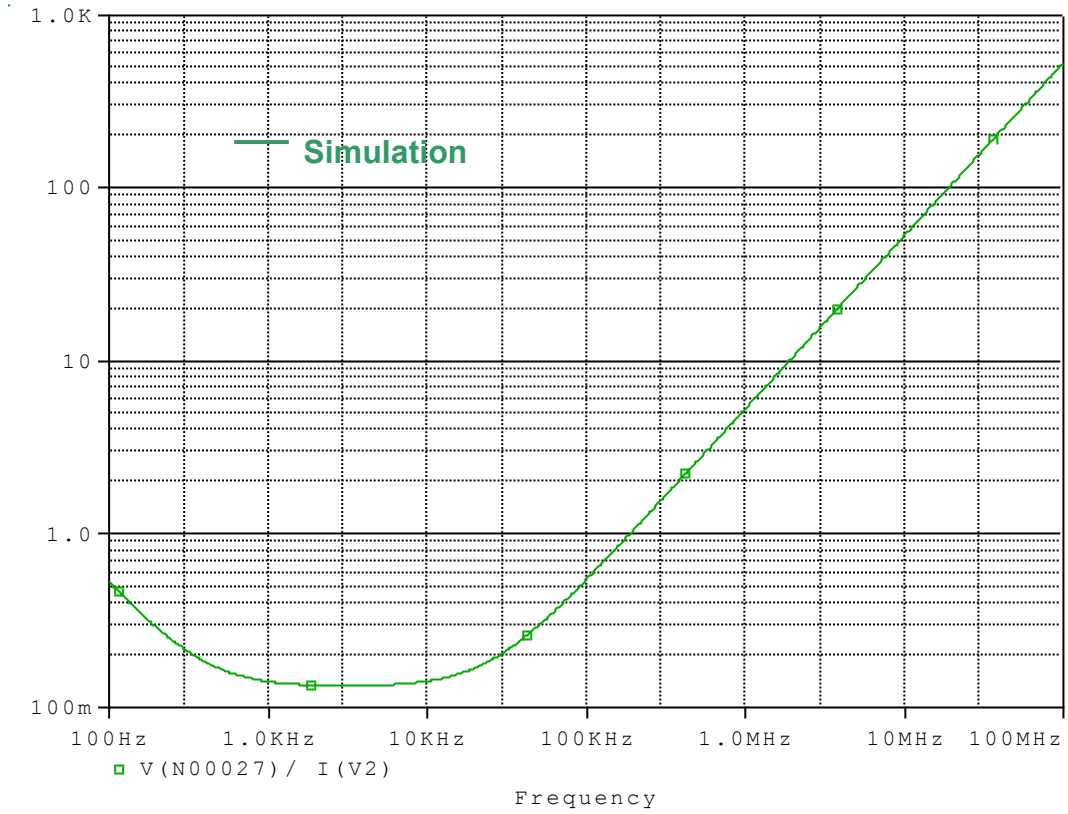

Evaluation Circuit

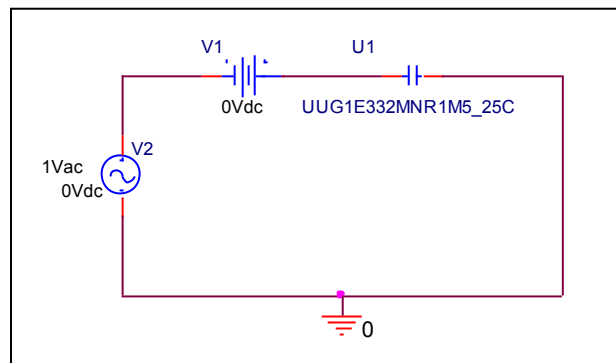

Simulation result

Frequency (Hz)	IZI (Ω)		% Error
	Measurement	Simulation	
100	515.928m	531.886m	3.093
1K	139.253m	141.319m	1.484
10K	134.257m	141.397m	5.318
100K	563.635m	548.257m	- 2.728
1M	5.618	5.324	- 5.235
10M	53.716	53.226	- 0.913