

Device Modeling Report

COMPONENTS: VOLTAGE REGULATOR
PART NUMBER: LM7815
MANUFACTURER: FAIRCHILD SEMICONDUCTOR



Bee Technologies Inc.

MODEL PARAMETER

Pspice model parameter	Model description
VREF	Reference Voltage
N	Emission Coefficient
BETA	Tranconductance of JFET Transistor
VAF	Early Voltage of Output Pass Transistor
CPZ	Output Impedance Zero Capacitor
RB2	Base Resistance of Output Limit Voltage Source
ESC1	Coefficient of Current Limit Voltage Source
ESC2	Coefficient of Current Limit Voltage Source
EFB1	Coefficient of Foldback Current Voltage Source
EFB2	Coefficient of Foldback Current Voltage Source
EFB3	Coefficient of Foldback Current Voltage Source
EB	Non-ideal Base-Collector Diode Saturation Current

Input-Output Voltage Differential Characteristic

Simulation Result

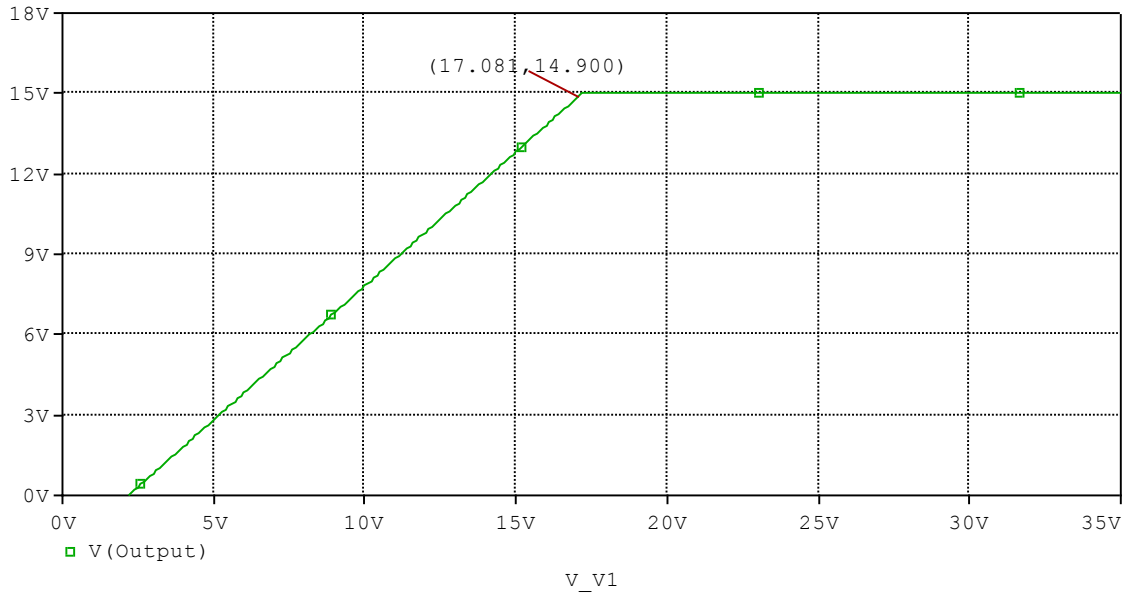

Evaluation Circuit

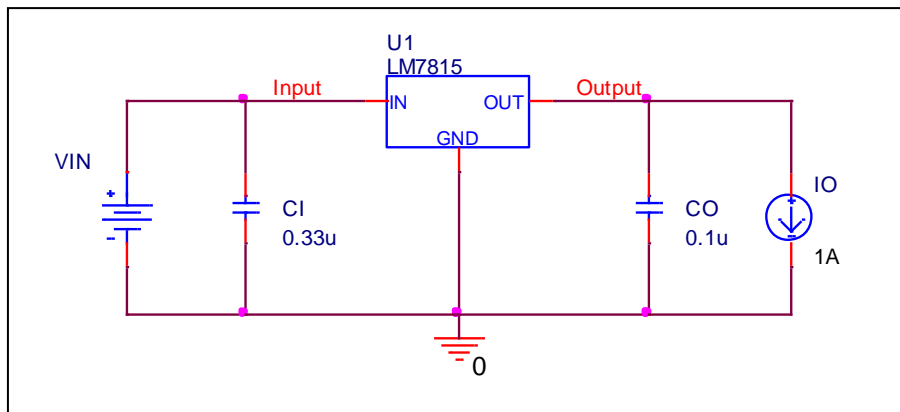

Comparison Table

Condition: $I_O = 1A$, $V_I = 23V$, $C_I = 0.33\mu F$, $C_O = 0.1\mu F$,

Parameter	Measurement	Simulation	%Error
$V_{DROP}(V)$	2.000	2.081	4.05

Ripple Rejection (R-R) Characteristic

Simulation Result

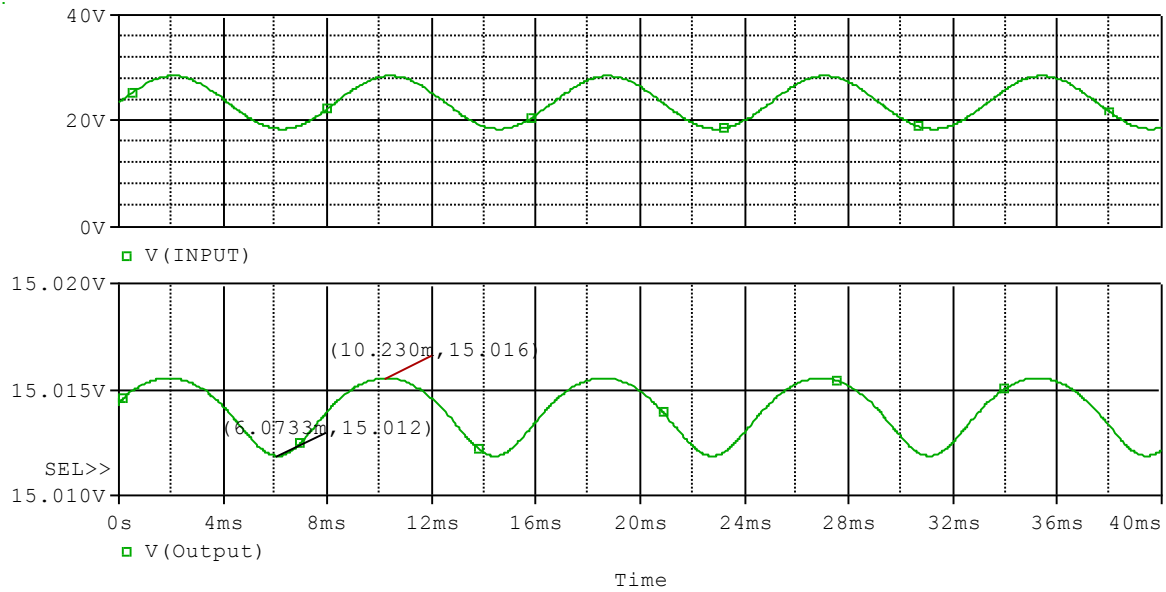

Evaluation Circuit

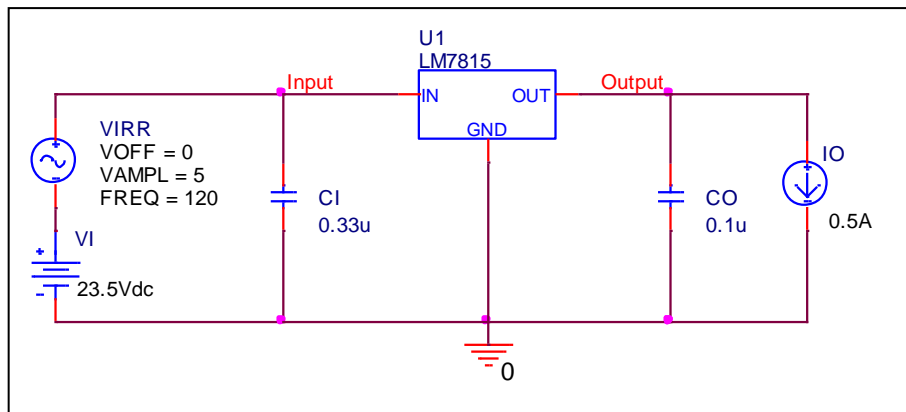

Comparison Table

Condition: $I_o = 500\text{mA}$, $V_i = 23\text{V}$, $C_i = 0.33\mu\text{F}$, $C_o = 0.1\mu\text{F}$, $f = 120\text{Hz}$, $V_o = 18.5\text{V}$ to 28.5V

Parameter	Measurement	Simulation	%Error
RR(dB)	70.000	68.712	-1.84

Output Characteristic

Simulation Result

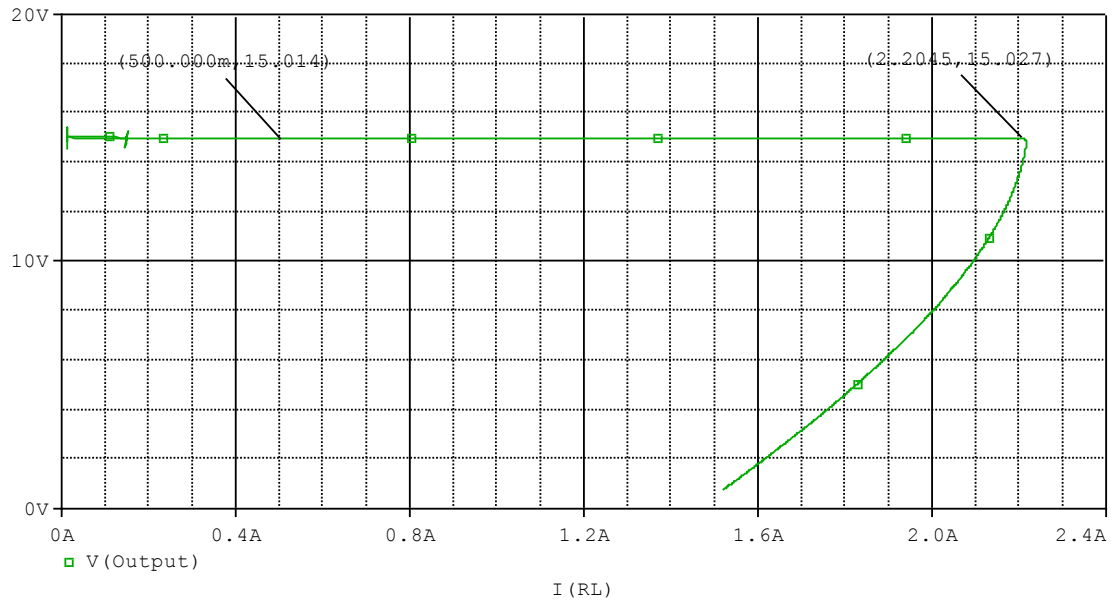

Evaluation Circuit

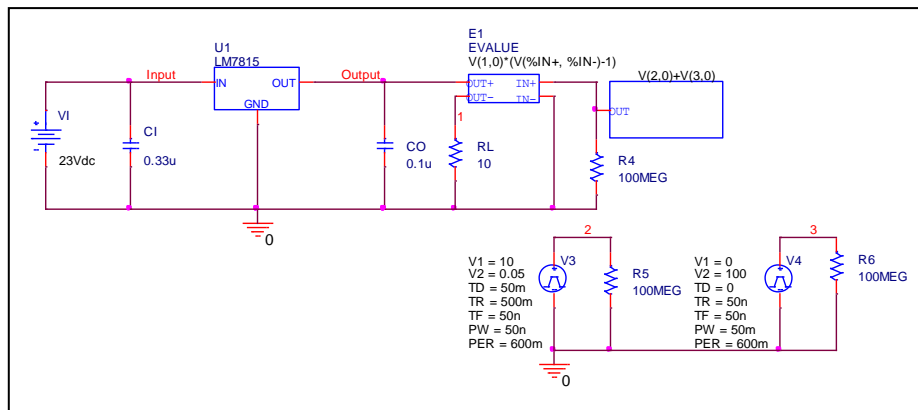

Comparison Table

Condition: $I_O = 250\text{mA}$ to 750mA , $V_I = 23\text{V}$, $C_I = 0.33\mu\text{F}$, $C_O = 0.1\mu\text{F}$,

Parameter	Measurement	Simulation	%Error
$V_O(\text{V})$	15.000	15.014	0.09
$I_{PK}(\text{A})$	2.200	2.205	0.20