

Device Modeling Report

COMPONENTS : VOLTAGE COMPARATOR
PART NUMBER : LM319AH
MANUFACTURER : NATIONAL



Bee Technologies Inc.

BJT MODEL

Pspice model parameter	Model description
IS	Saturation Current
BF	Ideal Maximum Forward Beta
CJC	Zero-bias Collector-Base Junction Capacitance
TF	Forward Transit Time
TR	Reverse Transit Time

DIODE MODEL

Pspice model parameter	Model description
IS	Saturation Current
RS	Series Resistance

Output Low Voltage

Simulation result

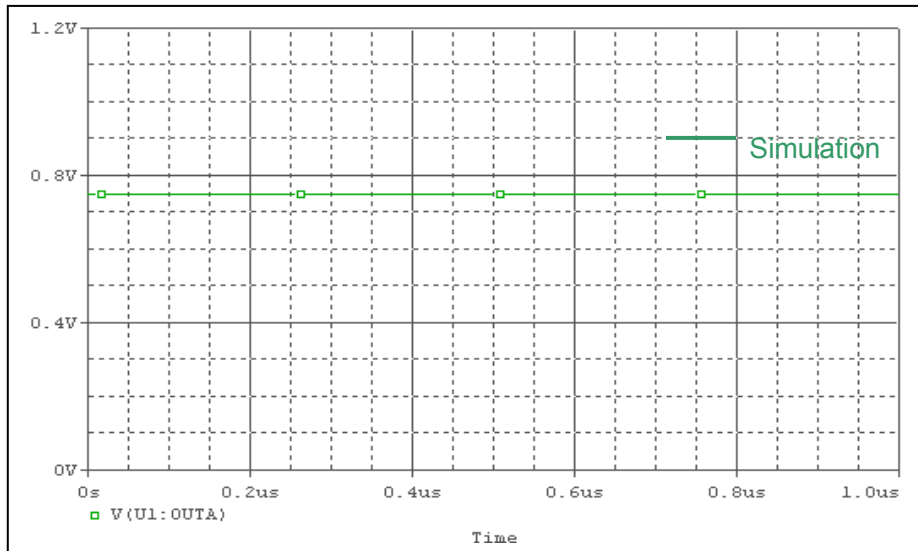

Evaluation Circuit

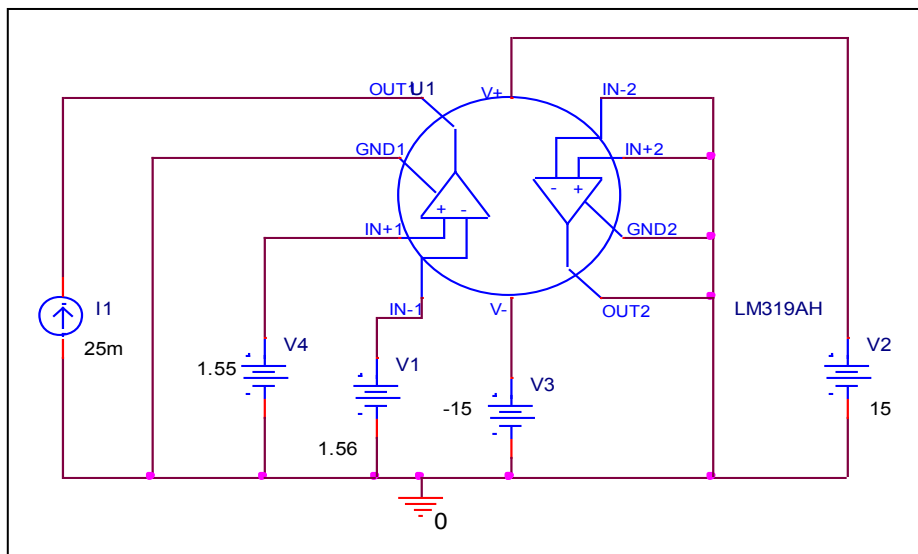

Comparison Table

$I_o = 25\text{mA}$	Measurement	Simulation	%Error
$V_{ol} \text{ (V)}$	0.75	0.750832	0.111

Response time (Rise time and Transition time)

Simulation result

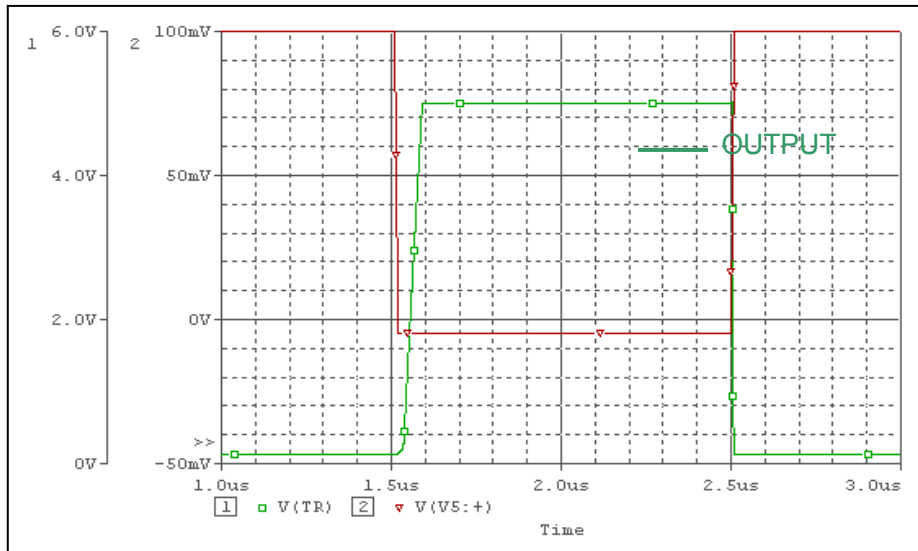

Evaluation Circuit

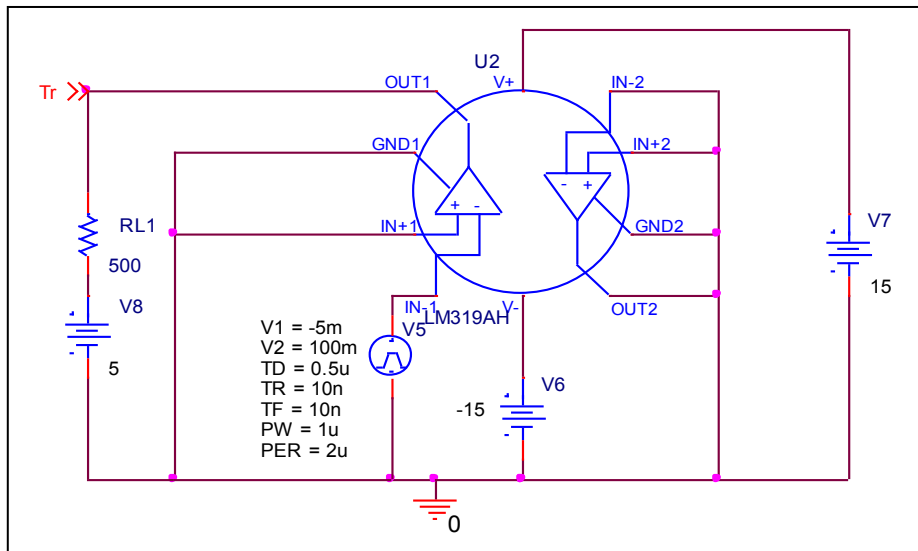

Comparison Table

	Measurement	Simulation	% Error
Rising delay time (ns)	30	30.223	0.743
Transition time (ns)	45	44.559	-0.980

Response time (Falling time)

Simulation result

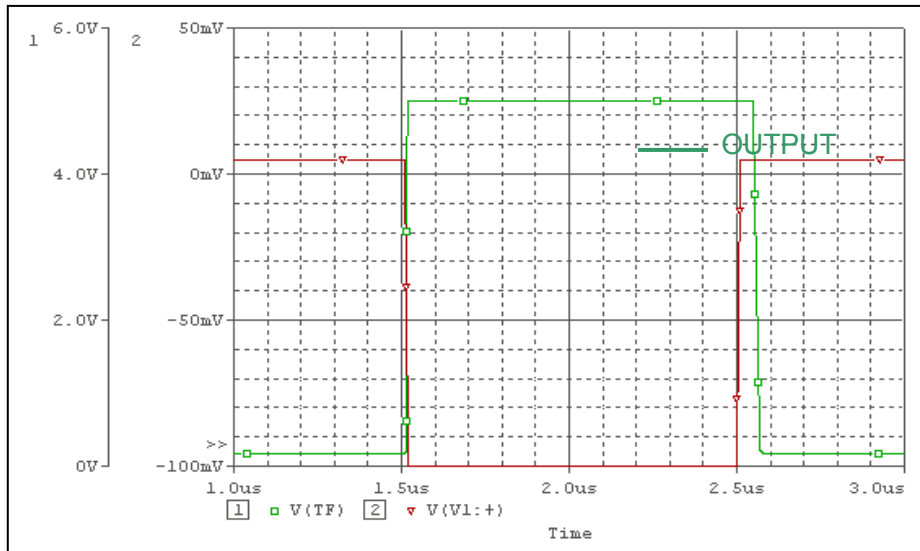

Evaluation Circuit

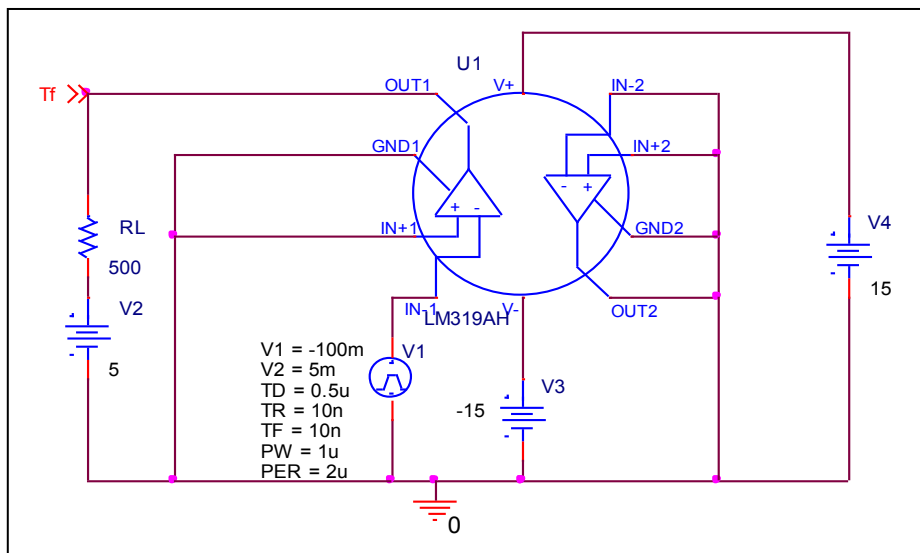

Comparison Table

	Measurement	Simulation	% Error
Falling delay time (ns)	50	50.029	0.058

Input Offset Voltage Characteristics

Simulation result

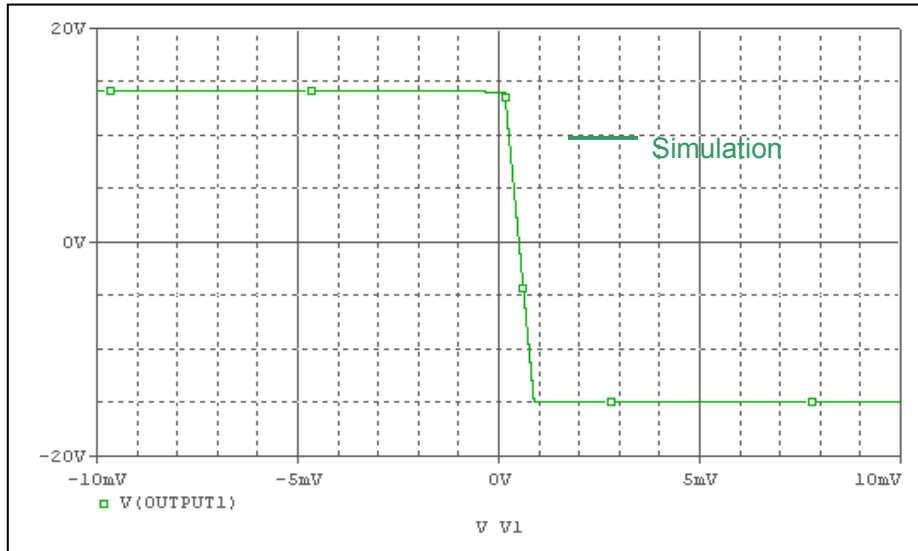

Evaluation Circuit

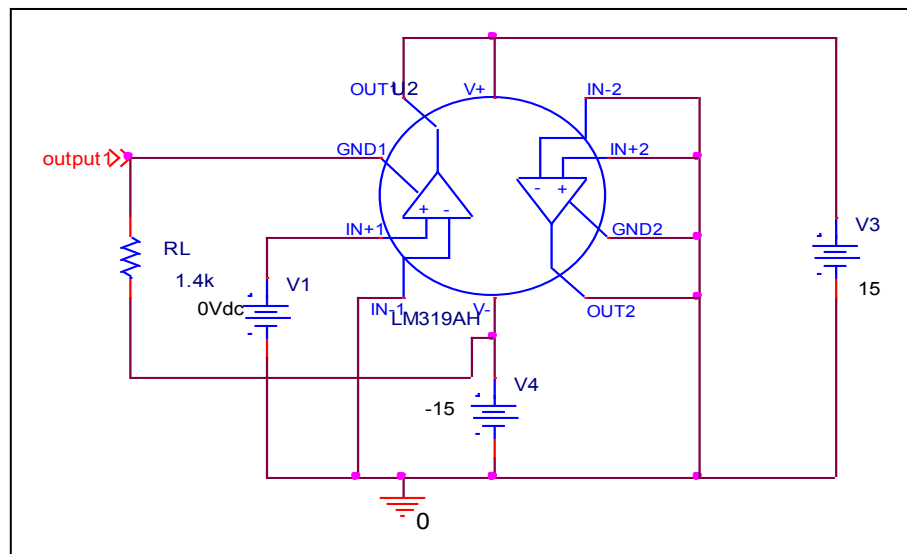

Comparison Table

	Measurement	Simulation	%Error
$V_{io}(\text{mV})$	0.5	0.500642	0.128

Av Characteristics

Simulation result

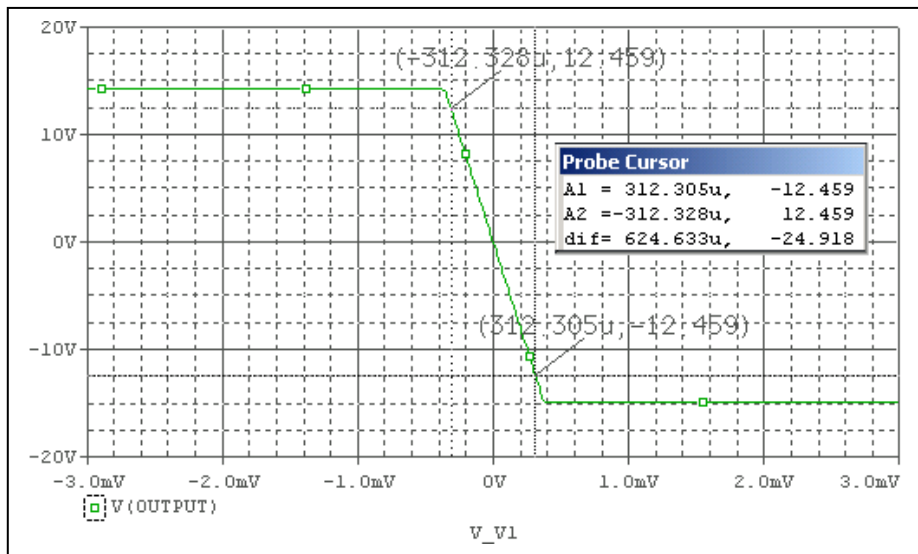

Evaluation Circuit

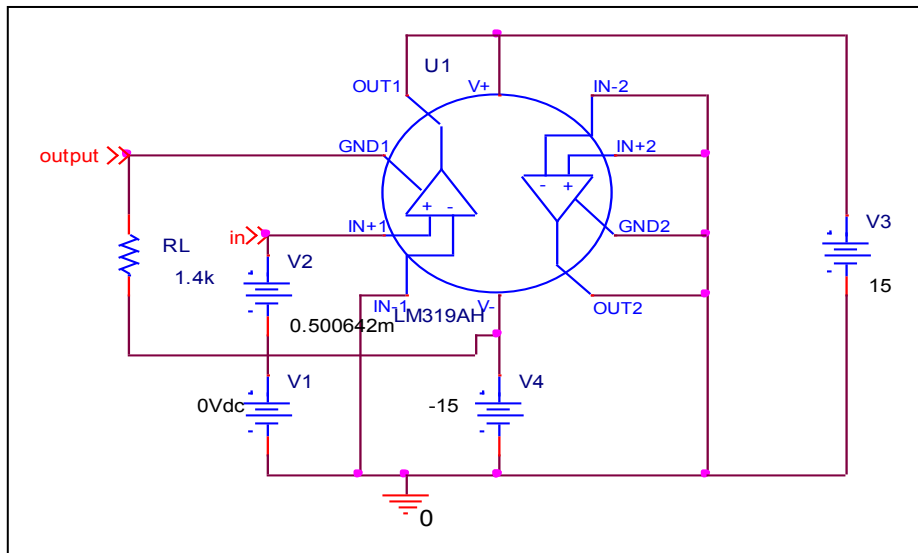

$$A_v = 24.918 / 624.633\mu$$

Comparison Table

	Measurement	Simulation	%Error
A_v (V/mV)	40	39.892	-0.270

Input Bias Current Characteristics

Simulation result

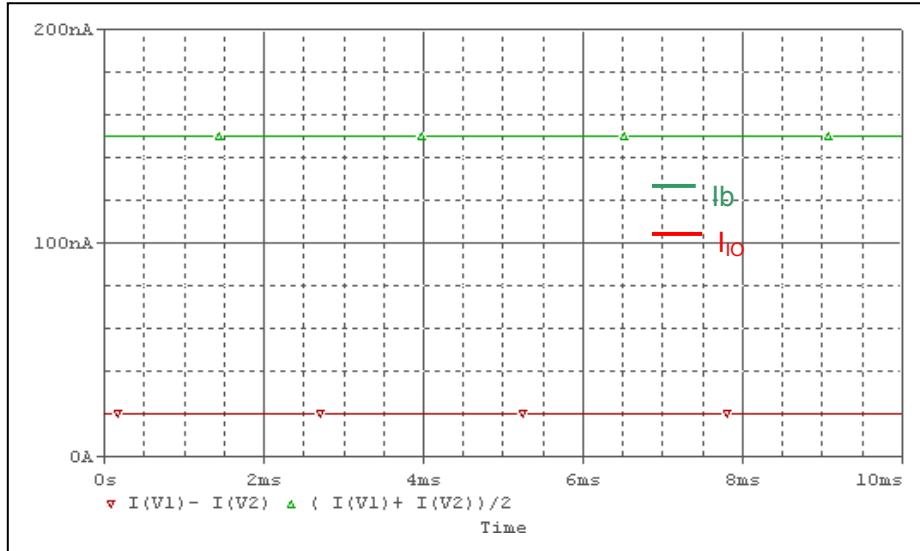

Evaluation Circuit

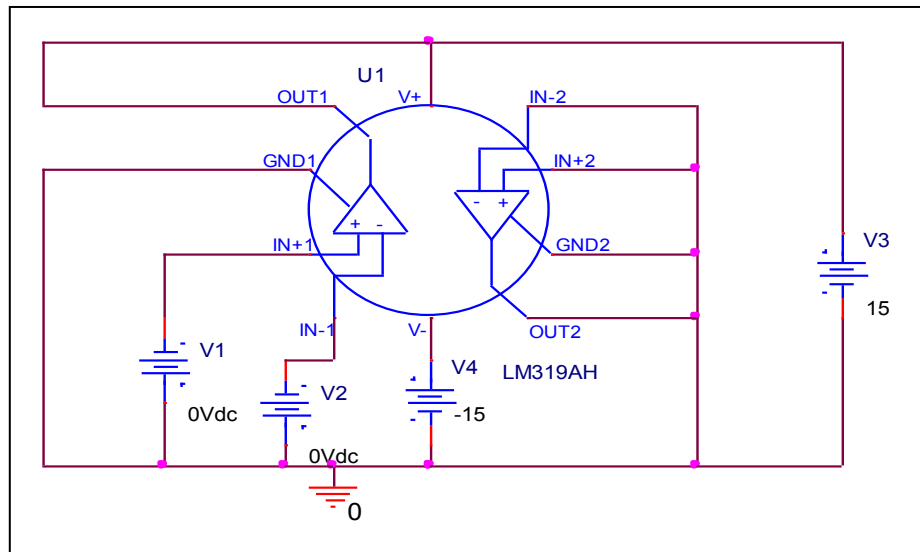

Comparison Table

	Measurement	Simulation	% Error
I_b (nA)	150	150.059	0.039
I_{io} (nA)	20	19.946	-0.270