

# Device Modeling Report

COMPONENTS: Inductance  
PART NUMBER: LQH44PN100MJ0  
MANUFACTURER: Murata Manufacturing Co., Ltd.  
Remark: DC Model



**Bee Technologies Inc.**

# Inductance-Current Characteristics

## Circuit Simulation result

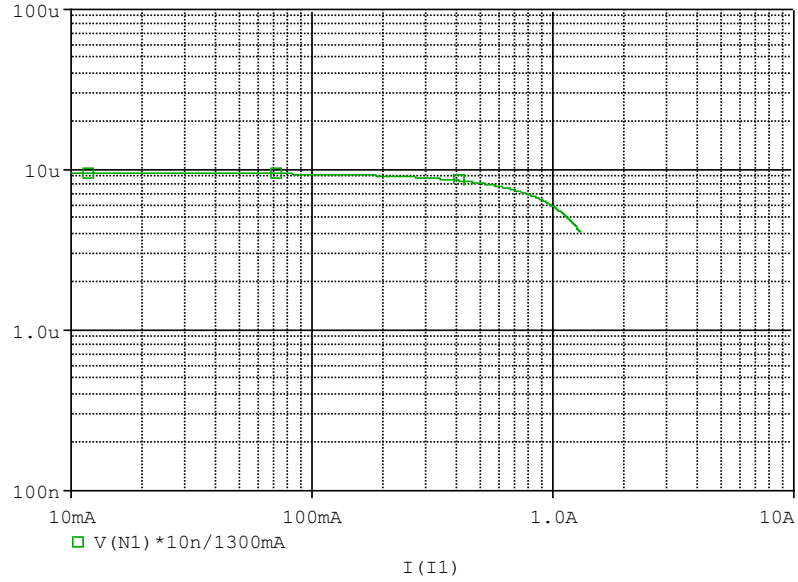

## Evaluation circuit

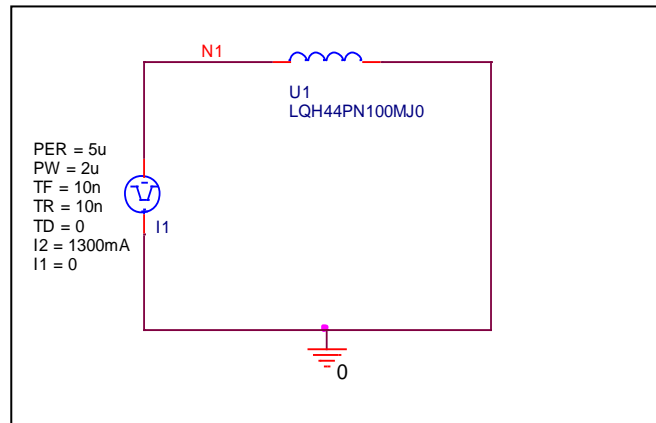

# Comparison Graph

## Simulation result

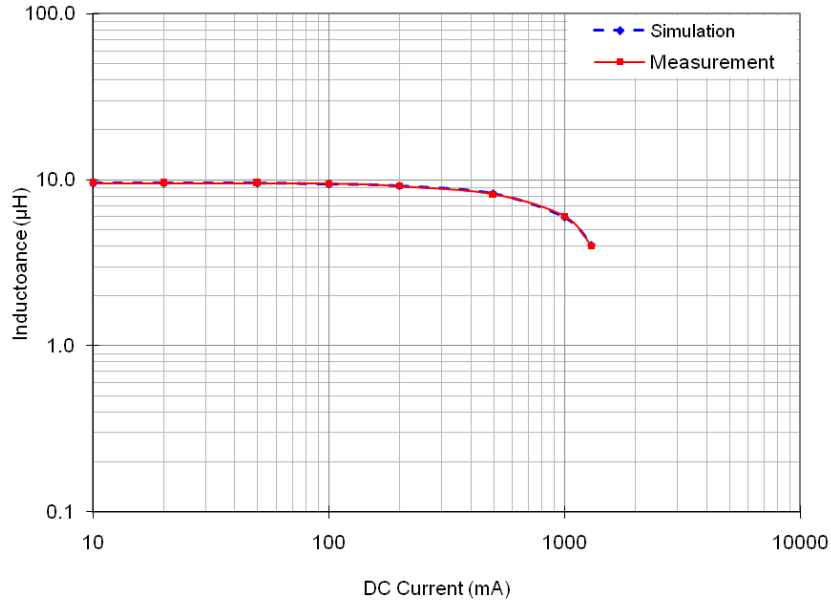

## Comparison table

I (mA)	L (µH)		%Error
	Measurement	Simulation	
10	9.500	9.500	0.00
20	9.500	9.500	0.00
50	9.500	9.489	-0.12
100	9.425	9.391	-0.36
200	9.150	9.166	0.17
500	8.150	8.252	1.25
1000	6.025	5.936	-1.48
1300	4.000	4.071	1.77