

Device Modeling Report

COMPONENTS: ZNR Transient/Surge Absorber
PART NUMBER: ERZV10D330
MANUFACTURER: Panasonic



Bee Technologies Inc.

ZNR Transient /Surge Absorber

Evaluation Circuit Result

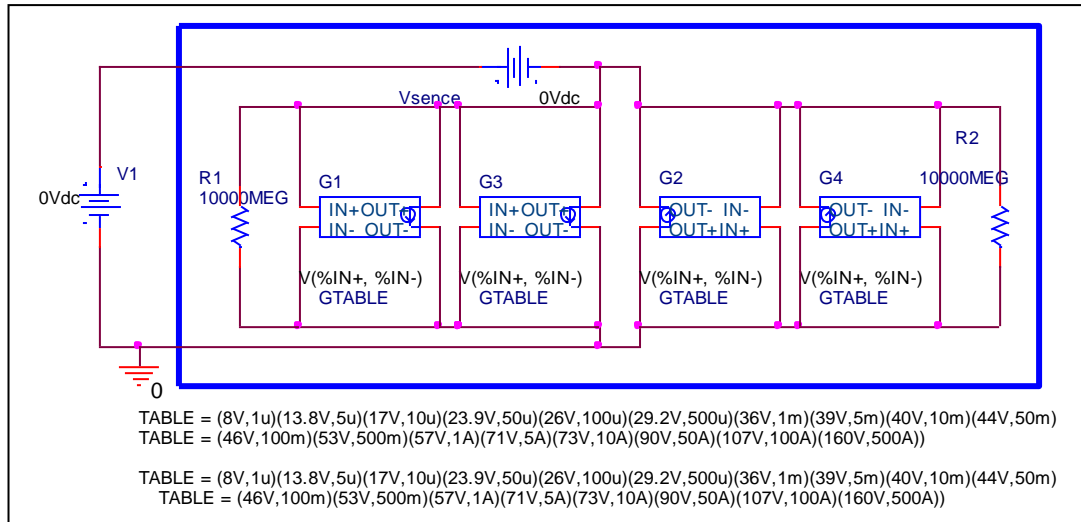

Circuit Simulation Result

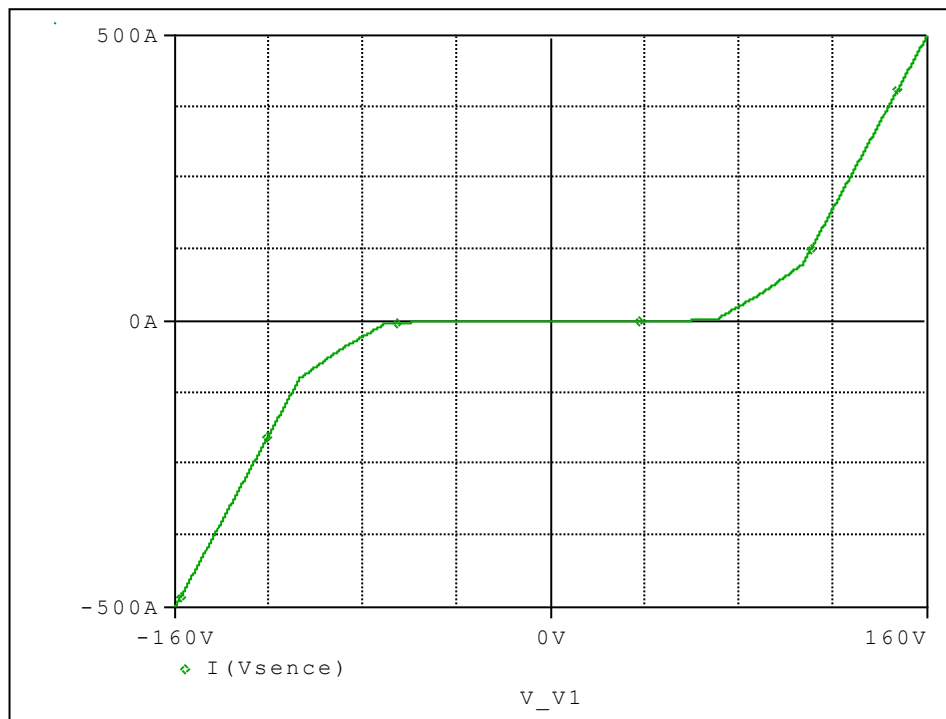

ZNR Transient /Surge Absorber

Simulation Result

I(A)	VFwd (V)		%Error
	Measurement	Simulation	
1.00E-05	8.000	8.500	6.250
5.00E-06	13.800	14.430	4.565
5.00E-05	17.000	17.170	1.000
1.00E-04	23.900	23.940	0.167
5.00E-04	26.000	26.000	0.000
1.00E-03	29.200	29.210	0.034
5.00E-03	36.000	36.000	0.000
1.00E-02	39.000	39.290	0.744
5.00E-02	40.000	40.000	0.000
1.00E-01	44.000	44.000	0.000
5.00E-01	46.000	46.870	1.891
1.00E+00	53.000	53.400	0.755
5.00E+00	57.000	57.170	0.298
1.00E+01	71.000	71.020	0.028
5.00E+01	73.000	73.020	0.027
1.00E+02	90.000	90.100	0.111
5.00E+02	107.000	107.000	0.000
1.00E+06	160.000	160.000	0.000

Comparison Graph

Circuit Simulation Result

