

Device Modeling Report

COMPONENTS: THYRISTOR
PART NUMBER: USF5J49
MANUFACTURER: TOSHIBA



Bee Technologies Inc.

DIODE MODEL

Pspice model Parameter	Model description
IS	Saturation Current
N	Emission Coefficient
RS	Series Resistance
IKF	High-injection Knee Current
CJO	Zero-bias Junction Capacitance
M	Junction Grading Coefficient
VJ	Junction Potential
ISR	Recombination Current Saturation Value
BV	Reverse Breakdown Voltage(a positive value)
IBV	Reverse Breakdown Current(a positive value)
TT	Transit Time

IG-VT Characteristic

Evaluation Circuit

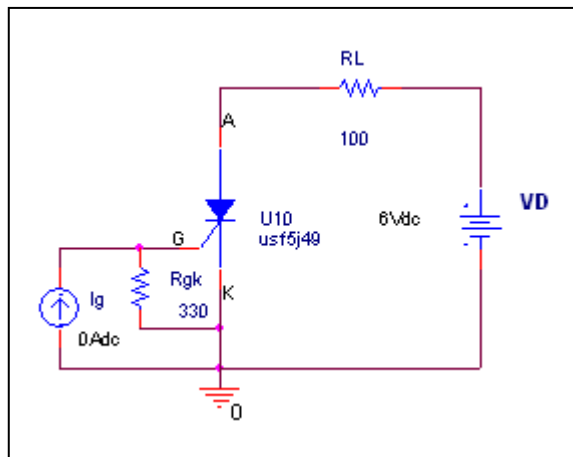

Simulation result

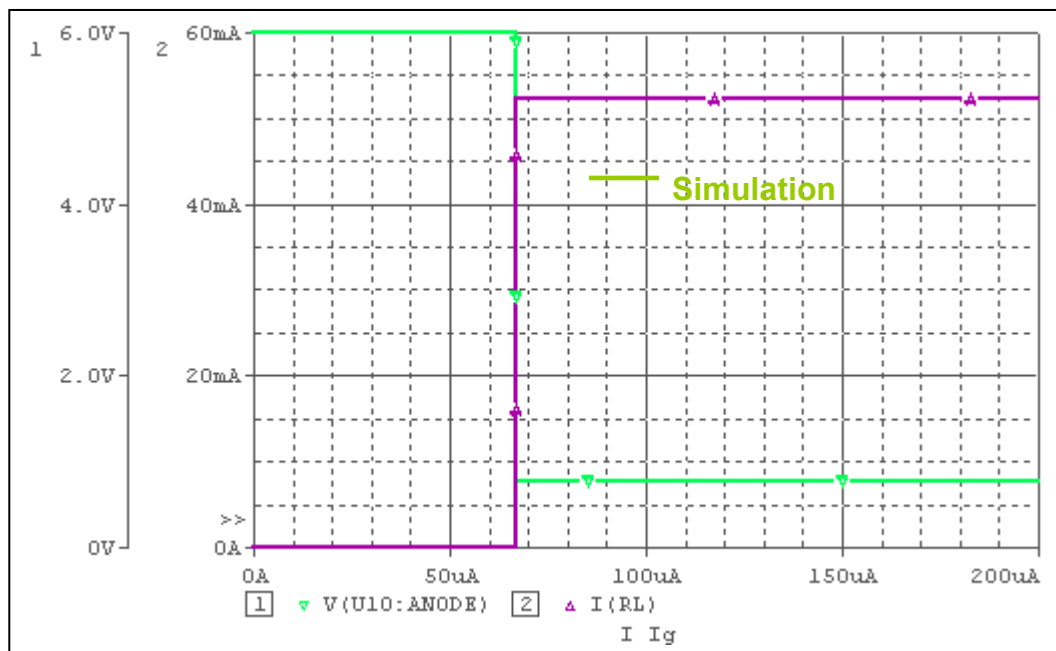

Comparison Table

	Measurement	Simulation	% Error
I_{GT} (uA)	70(max)	66.668	-4.7600
V_{GT} (V)	0.8(max)	0.765694	-4.2883

ITM-VTM Characteristic

Evaluation Circuit

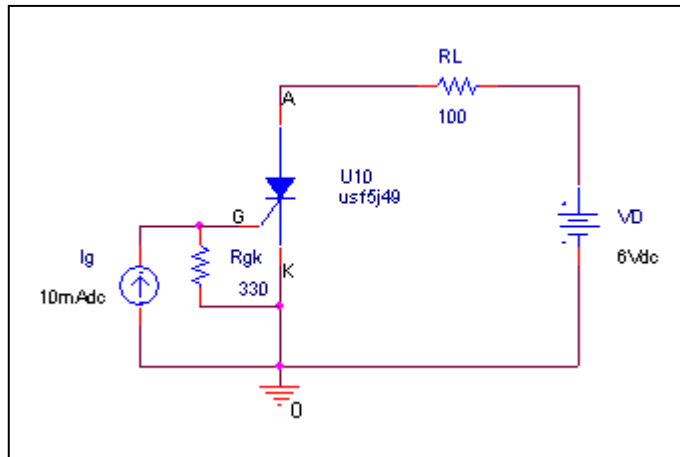

Simulation result

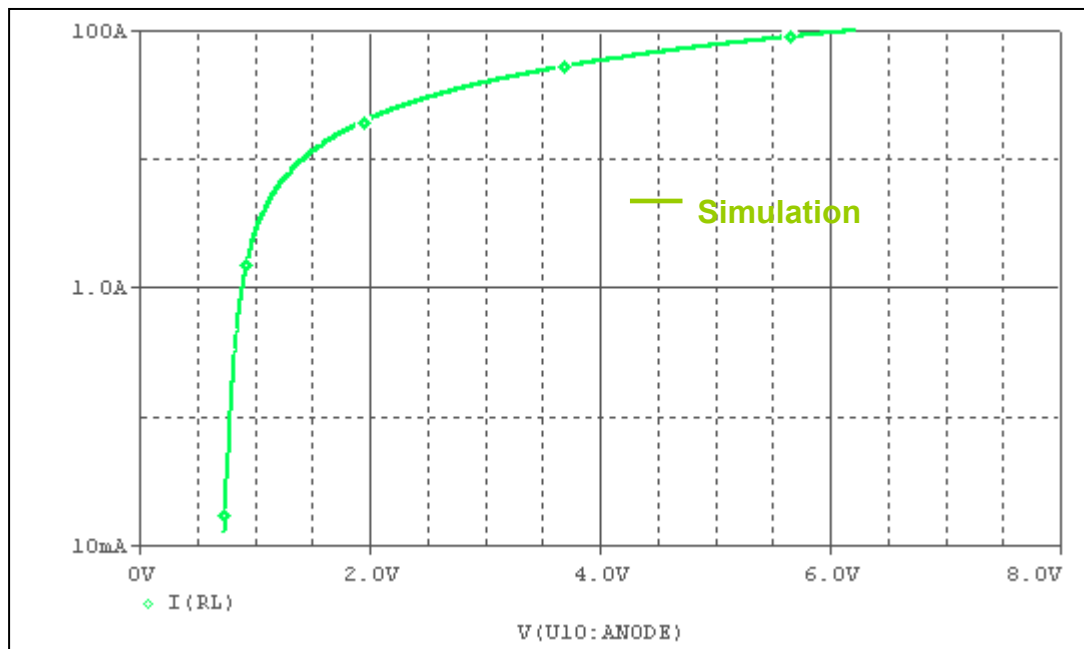

Comparison Table

At ITM=12A	Measurement	Simulation	% Error
VTM(V)	1.6(max)	1.5322	-4.2375

Holding Characteristic (IH)

Evaluation Circuit

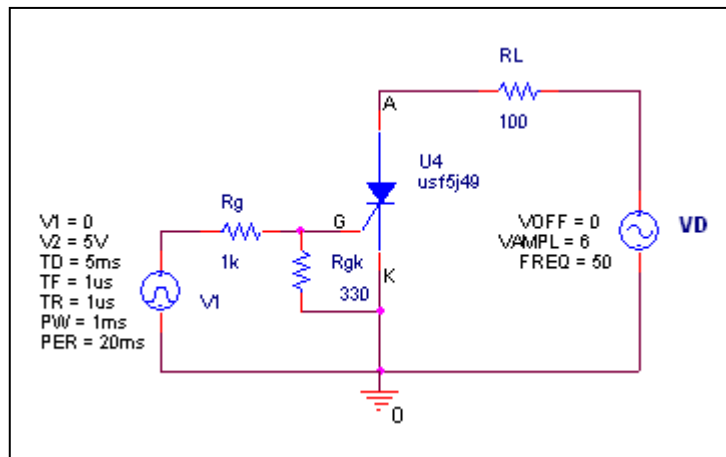

Simulation result

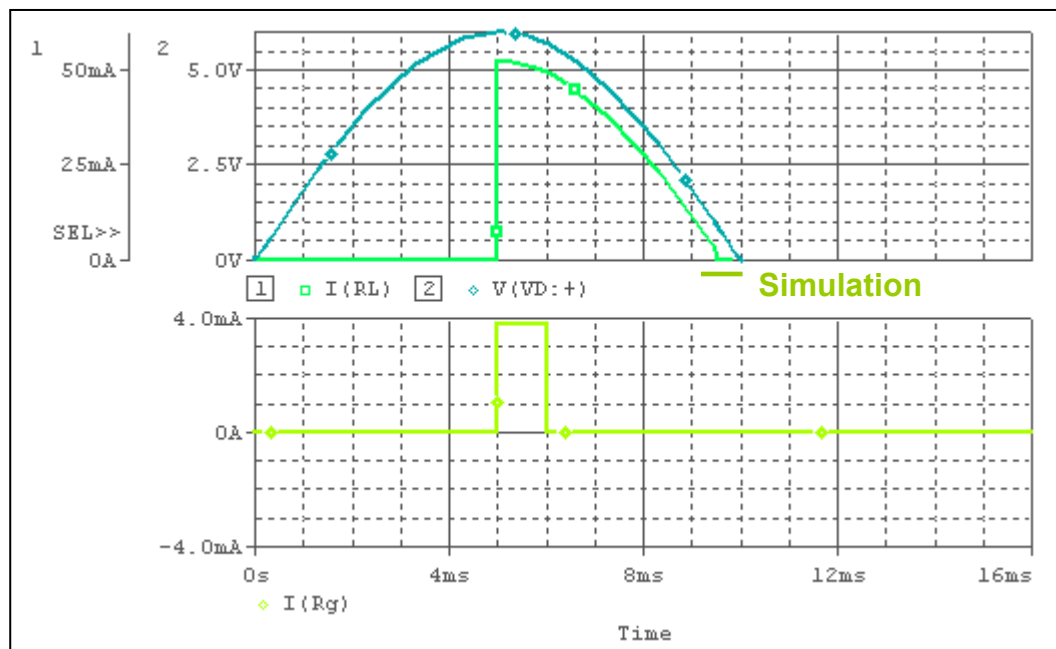

Comparison Table

VD=6V	Measurement	Simulation	% Error
IH(mA)	2.5	2.4404	-2.3840