

Device Modeling Report

COMPONENTS: Digital transistors (built-in resistors)
PART NUMBER: DTC114ESA
MANUFACTURER: ROHM



Bee Technologies Inc.

PSpice model parameter	Model description
IS	Saturation Current
BF	Ideal Maximum Forward Beta
NF	Forward Current Emission Coefficient
VAF	Forward Early Voltage
IKF	Forward Beta Roll-off Knee Current
ISE	Non-ideal Base-Emitter Diode Saturation Current
NE	Non-ideal Base-Emitter Diode Emission Coefficient
BR	Ideal Maximum Reverse Beta
NR	Reverse Emission Coefficient
VAR	Reverse Early Voltage
IKR	Reverse Beta Roll-off Knee Current
ISC	Non-ideal Base-Collector Diode Saturation Current
NC	Non-ideal Base-Collector Diode Emission Coefficient
NK	Forward Beta Roll-off Slope Exponent
RE	Emitter Resistance
RB	Base Resistance
RC	Series Collector Resistance
CJE	Zero-bias Emitter-Base Junction Capacitance
VJE	Emitter-Base Junction Potential
MJE	Emitter-Base Junction Grading Coefficient
CJC	Zero-bias Collector-Base Junction Capacitance
VJC	Collector-base Junction Potential
MJC	Collector-base Junction Grading Coefficient
FC	Coefficient for Onset of Forward-bias Depletion Capacitance
TF	Forward Transit Time
XTF	Coefficient for TF Dependency on Vce
VTF	Voltage for TF Dependency on Vce
ITF	Current for TF Dependency on Ic
PTF	Excess Phase at $f=1/2\pi*TF$
TR	Reverse Transit Time
EG	Activation Energy
XTB	Forward Beta Temperature Coefficient
XTI	Temperature Coefficient for IS

Input voltage vs. output current (ON characteristics)

Circuit simulation result

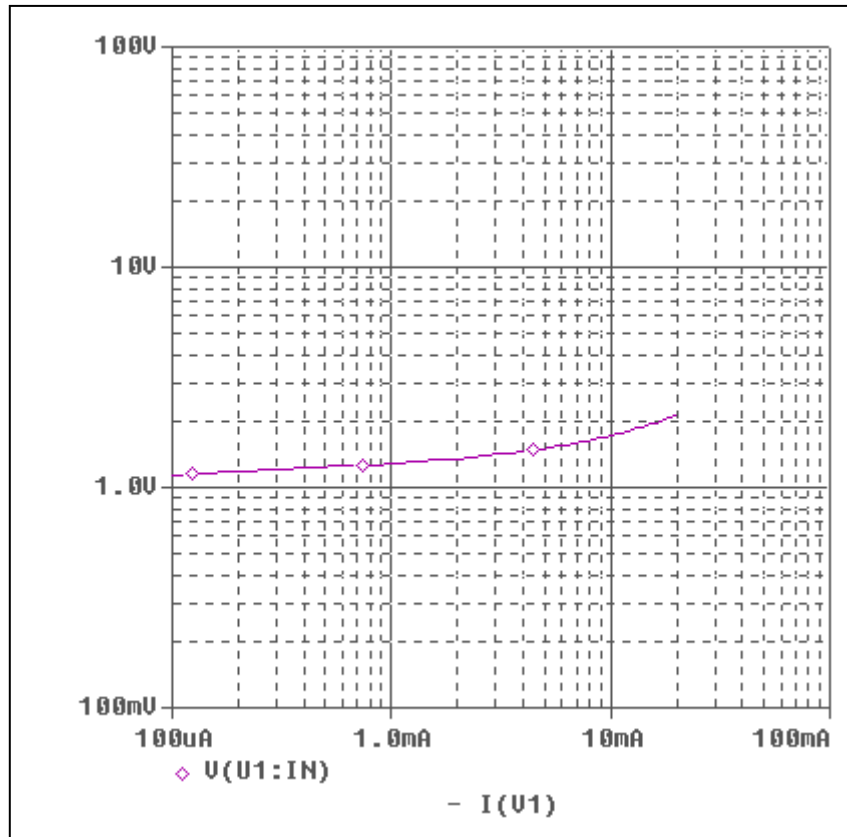

Evaluation circuit

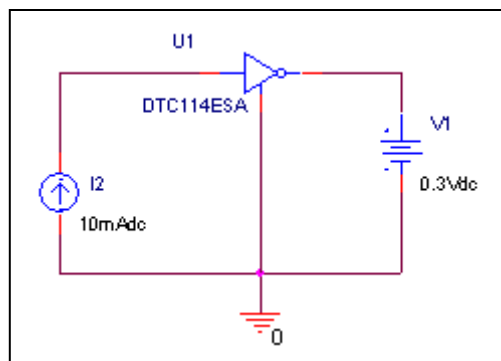

Comparison Graph

Circuit Simulation Result

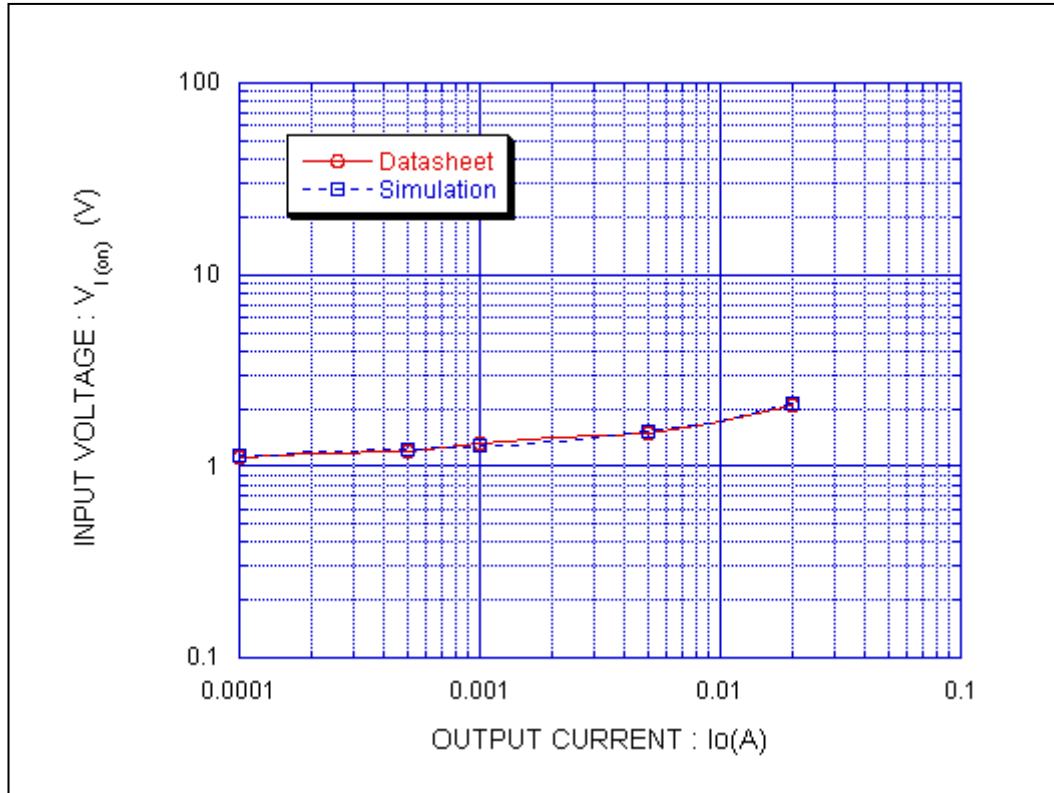

Simulation Result

Condition @ $V_o = 0.3$ V

I_o (A)	$V_{I(ON)}$ (V)		Error (%)
	Datasheet	Simulation	
100u	1.1	1.1436	3.96364
200u	1.17	1.1805	0.89744
500u	1.2	1.2370	3.08333
1m	1.3	1.2885	-0.88462
2m	1.4	1.3578	-3.01429
5m	1.5	1.5057	0.38000
10m	1.7	1.7203	1.19412
20m	2.1	2.1509	2.42381

Output current vs. input voltage (OFF characteristics)

Circuit simulation result

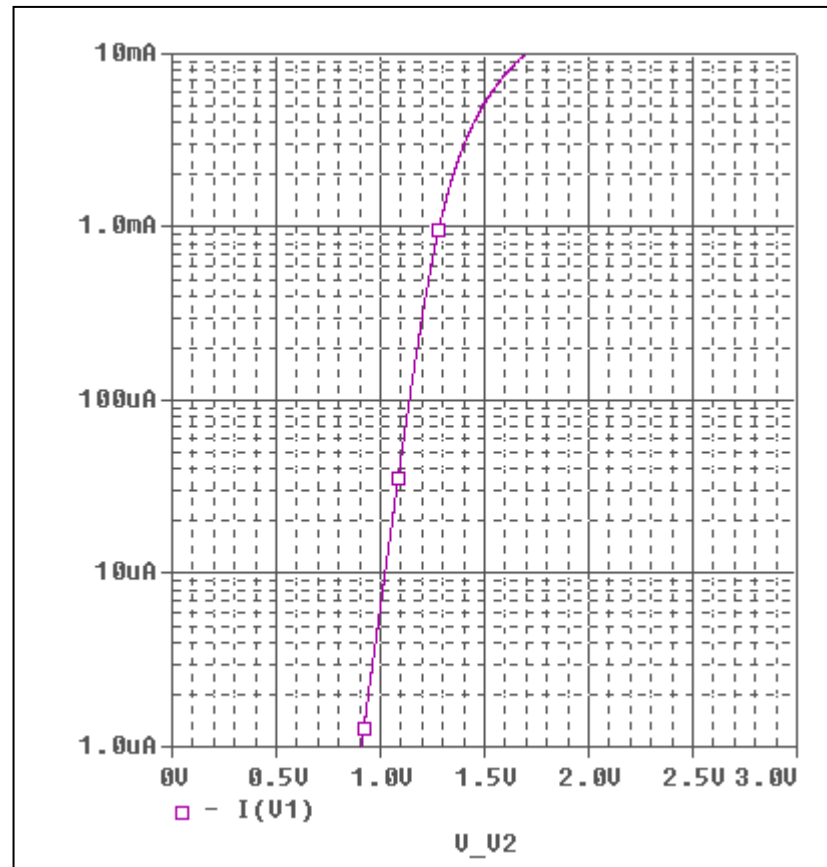

Evaluation circuit

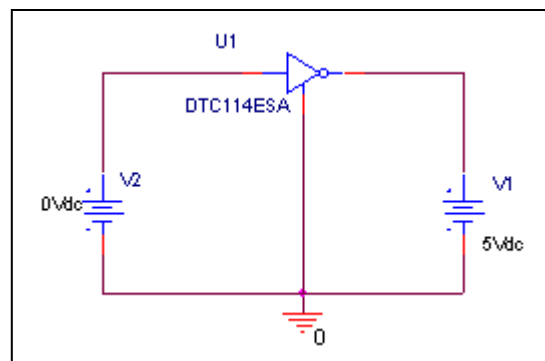

Comparison Graph

Circuit Simulation Result

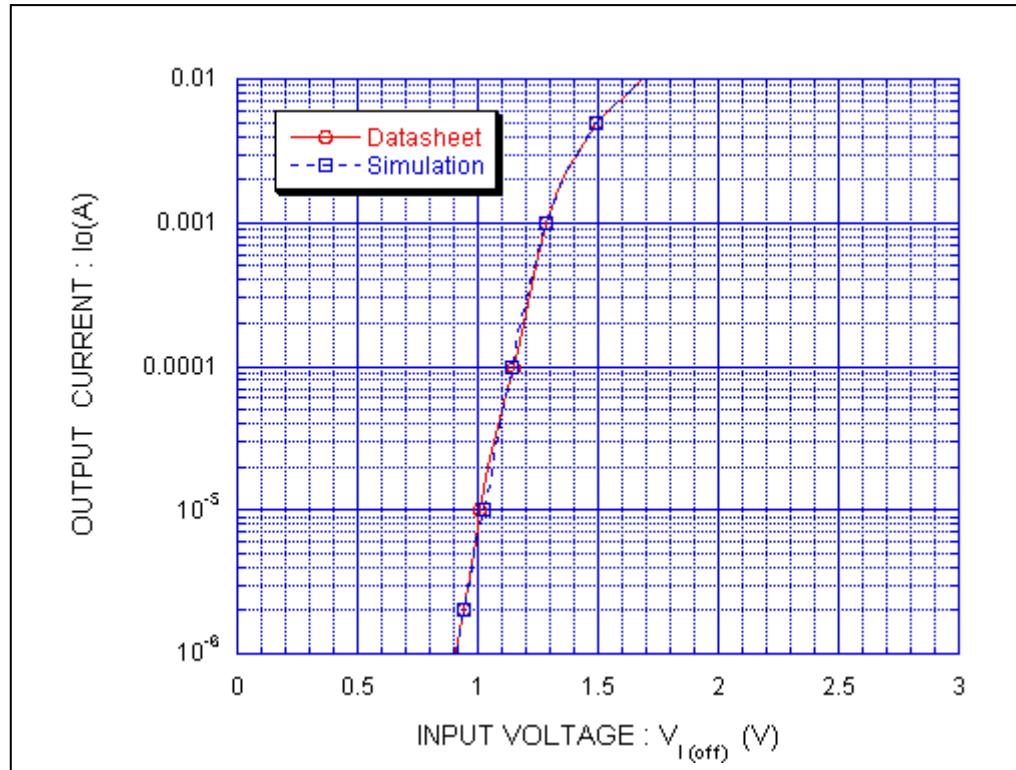

Simulation Result

Condition @ $V_{CC} = 5\text{ V}$

I_o (A)	$V_{I(off)}$ (V)		Error (%)
	Datasheet	Simulation	
1u	0.9	0.907660	0.85111
2u	0.94	0.942051	0.21819
5u	0.98	0.986207	0.63337
10u	1.01	1.0225	1.23762
20u	1.04	1.0586	1.78846
50u	1.1	1.1029	0.26364
100u	1.15	1.1404	-0.83478
200u	1.19	1.1769	-1.10084
500u	1.24	1.2328	-0.58065
1m	1.28	1.2828	0.21875
2m	1.35	1.3508	0.05926
5m	1.49	1.4931	0.20805
10m	1.68	1.6942	0.84524

DC current gain vs. output current

Circuit simulation result

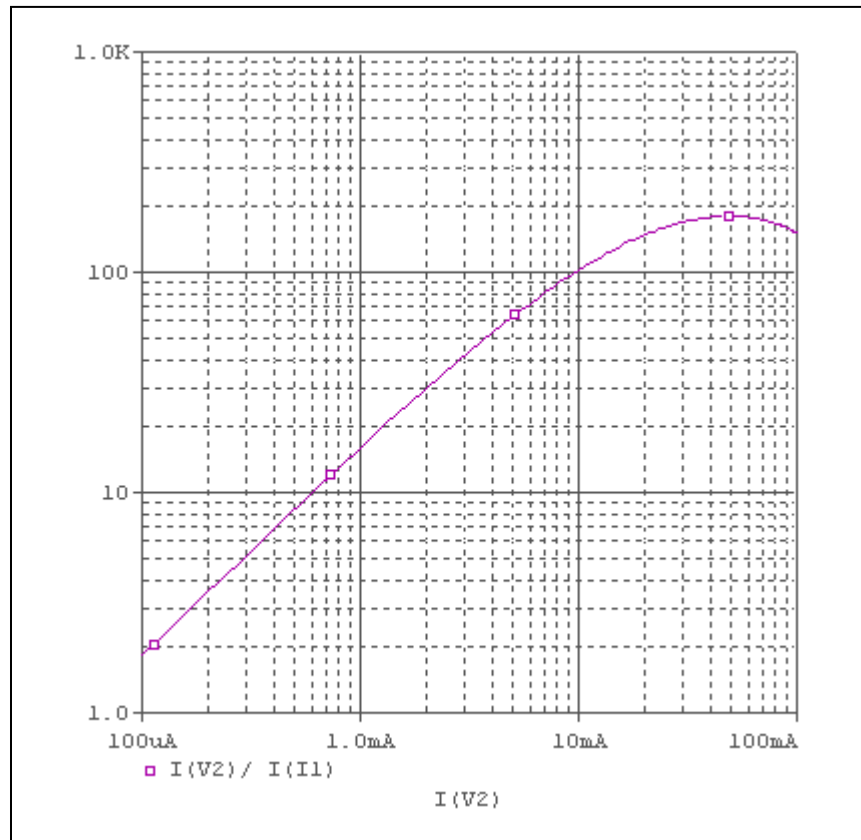

Evaluation circuit

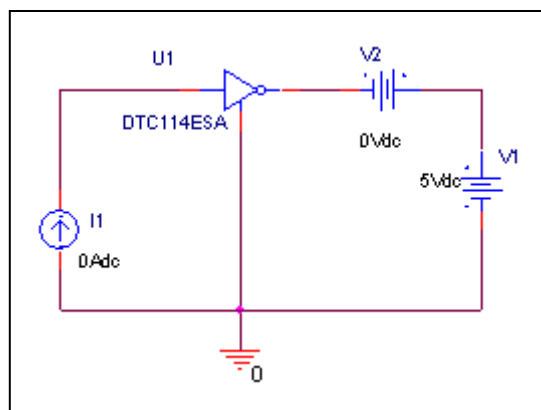

Comparison Graph

Circuit Simulation Result

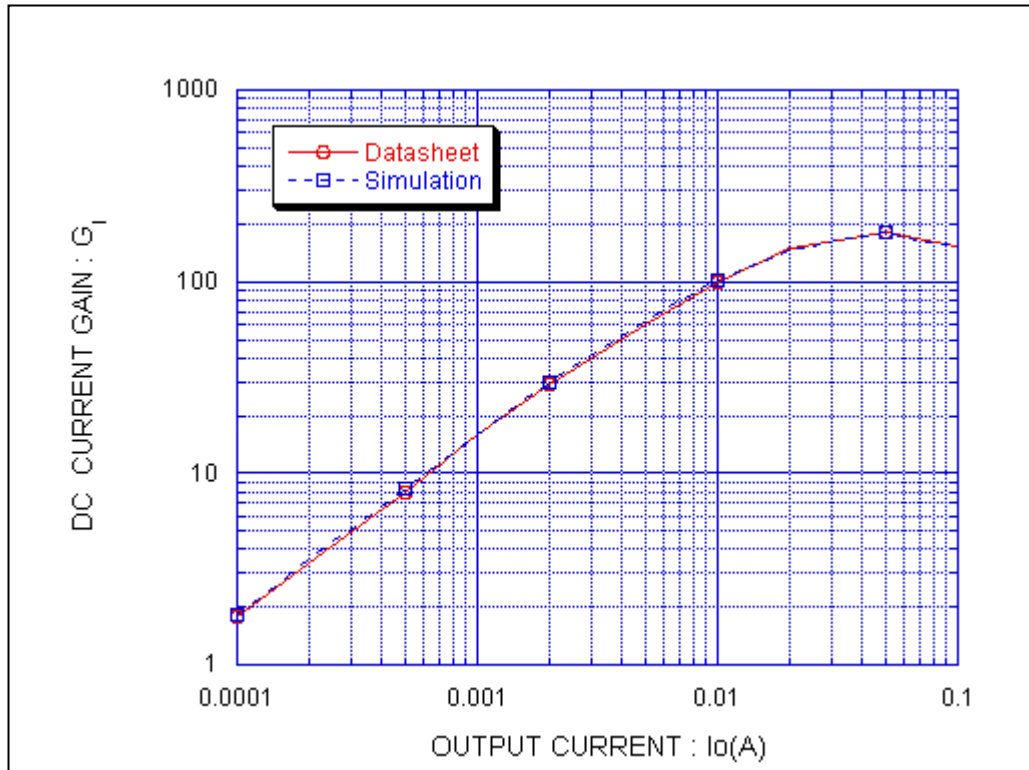

Simulation Result

Condition @ $V_{CC} = 5\text{ V}$

I_o (A)	$V_{I(off)}$ (V)		Error (%)
	Datasheet	Simulation	
100u	1.8	1.8100	0.55556
200u	3.4	3.5469	4.32059
500u	8	8.3834	4.79250
1m	16	15.912	-0.55000
2m	29	29.572	1.97241
5m	60	62.846	4.74333
10m	100	102.162	2.16200
20m	150	147.118	-1.92133
50m	180	179.771	-0.12722
100m	150	151.130	0.75333

Output voltage VS. output current

Circuit simulation result

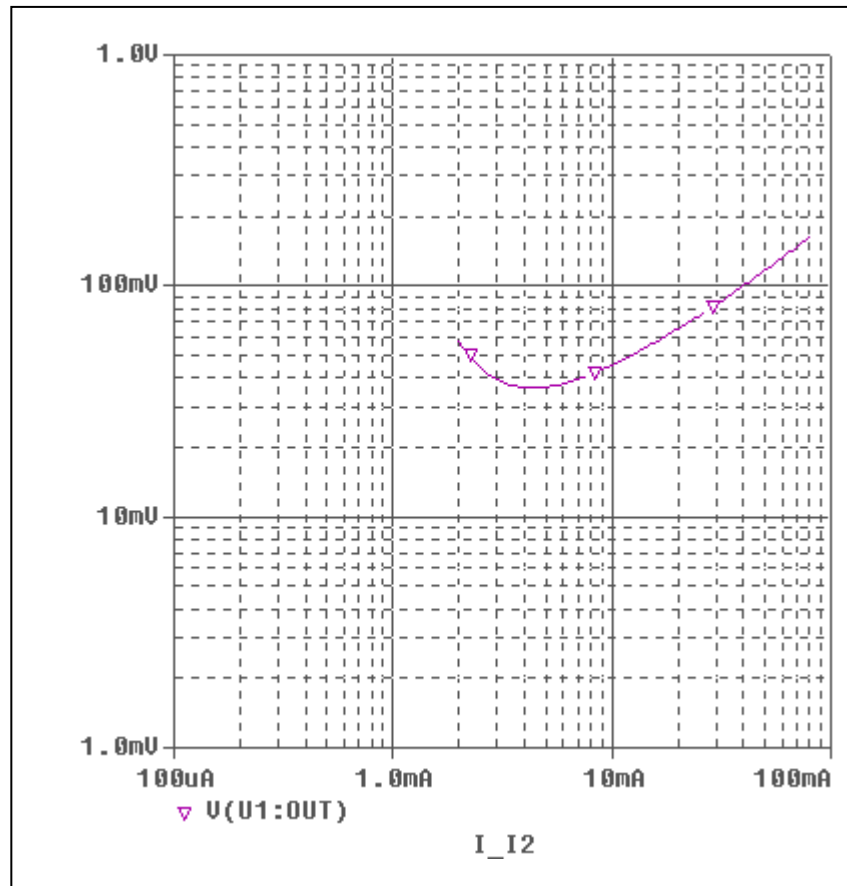

Evaluation circuit

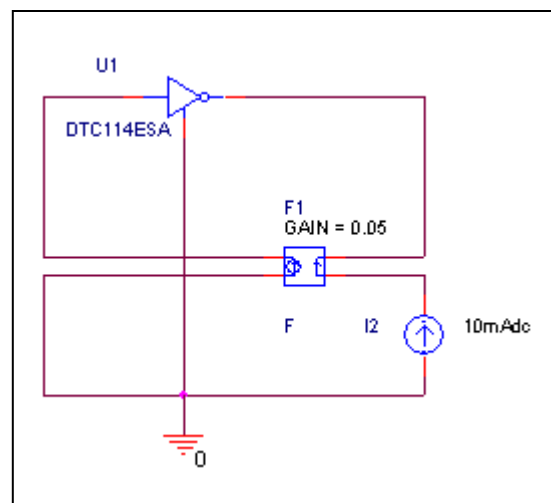

Comparison Graph

Circuit Simulation Result

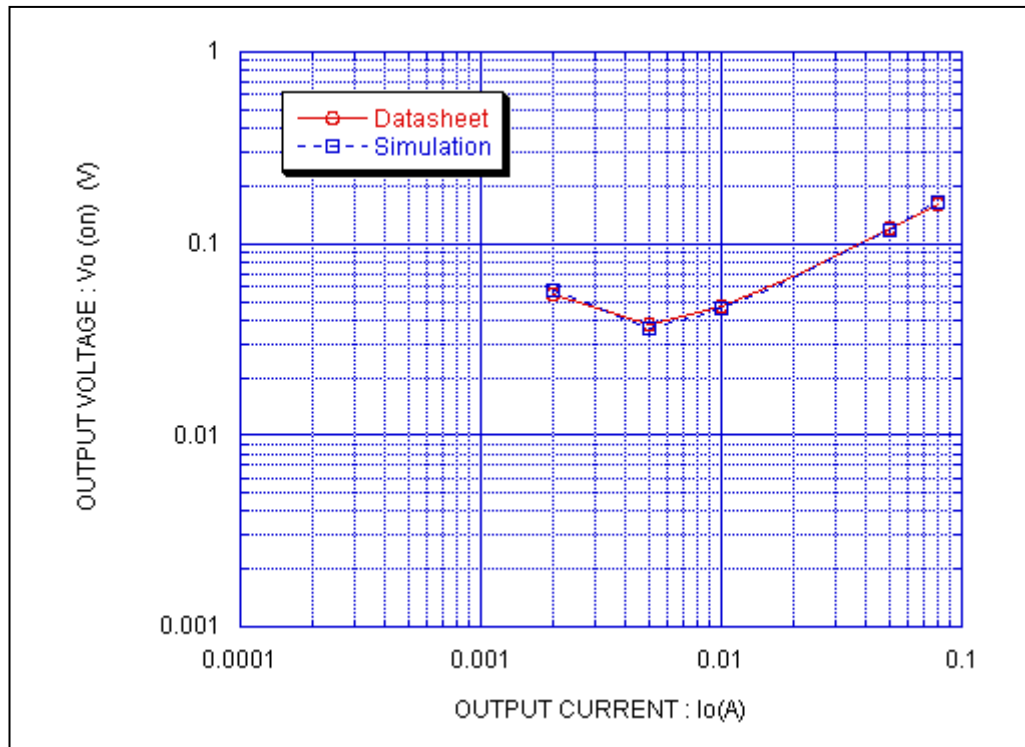

Simulation Result

Condition @ $I_o/I_i = 20$

I_o (A)	$V_{I(off)}$ (V)		Error (%)
	Datasheet	Simulation	
2m	55m	57.139m	3.88909
5m	38m	36.542m	-3.83684
10m	47m	45.455m	-3.28723
20m	67m	65.453m	-2.30896
50m	120m	117.331m	-2.22417
80m	160m	163.009m	1.88062