

Device Modeling Report

COMPONENTS: Digital transistors (built-in resistors)
PART NUMBER: DTC124EE
MANUFACTURER: ROHM



Bee Technologies Inc.

PSpice model parameter	Model description
IS	Saturation Current
BF	Ideal Maximum Forward Beta
NF	Forward Current Emission Coefficient
VAF	Forward Early Voltage
IKF	Forward Beta Roll-off Knee Current
ISE	Non-ideal Base-Emitter Diode Saturation Current
NE	Non-ideal Base-Emitter Diode Emission Coefficient
BR	Ideal Maximum Reverse Beta
NR	Reverse Emission Coefficient
VAR	Reverse Early Voltage
IKR	Reverse Beta Roll-off Knee Current
ISC	Non-ideal Base-Collector Diode Saturation Current
NC	Non-ideal Base-Collector Diode Emission Coefficient
NK	Forward Beta Roll-off Slope Exponent
RE	Emitter Resistance
RB	Base Resistance
RC	Series Collector Resistance
CJE	Zero-bias Emitter-Base Junction Capacitance
VJE	Emitter-Base Junction Potential
MJE	Emitter-Base Junction Grading Coefficient
CJC	Zero-bias Collector-Base Junction Capacitance
VJC	Collector-base Junction Potential
MJC	Collector-base Junction Grading Coefficient
FC	Coefficient for Onset of Forward-bias Depletion Capacitance
TF	Forward Transit Time
XTF	Coefficient for TF Dependency on Vce
VTF	Voltage for TF Dependency on Vce
ITF	Current for TF Dependency on Ic
PTF	Excess Phase at $f=1/2\pi*TF$
TR	Reverse Transit Time
EG	Activation Energy
XTB	Forward Beta Temperature Coefficient
XTI	Temperature Coefficient for IS

Input voltage vs. output current (ON characteristics)

Circuit simulation result

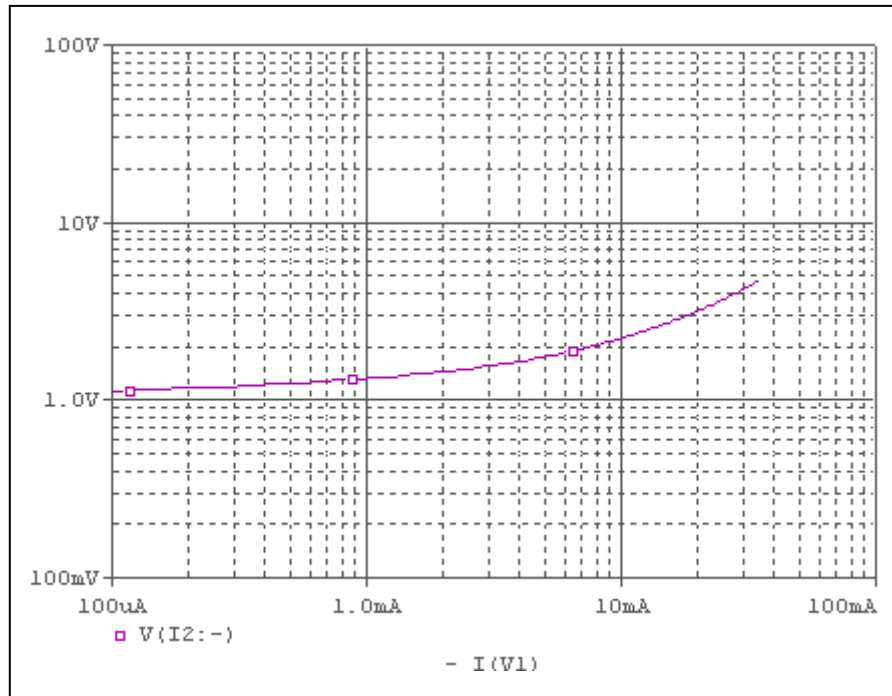

Evaluation circuit

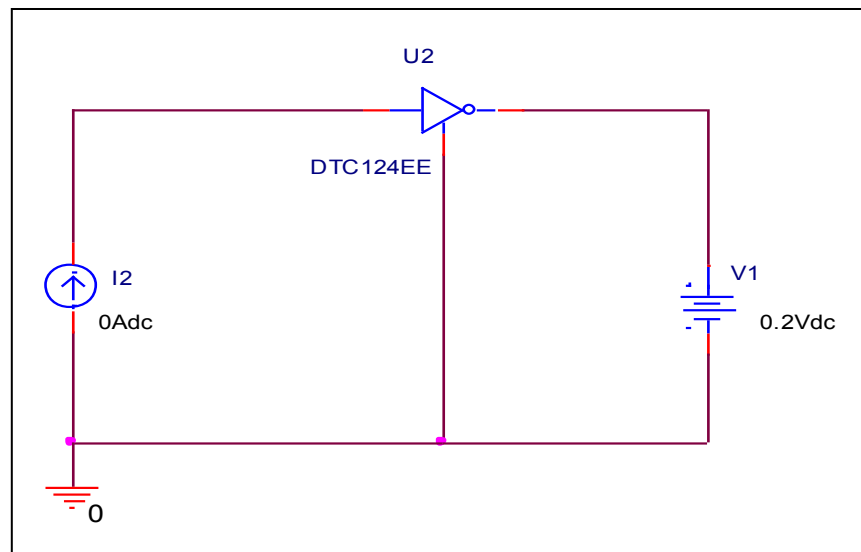

Comparison Graph

Circuit Simulation Result

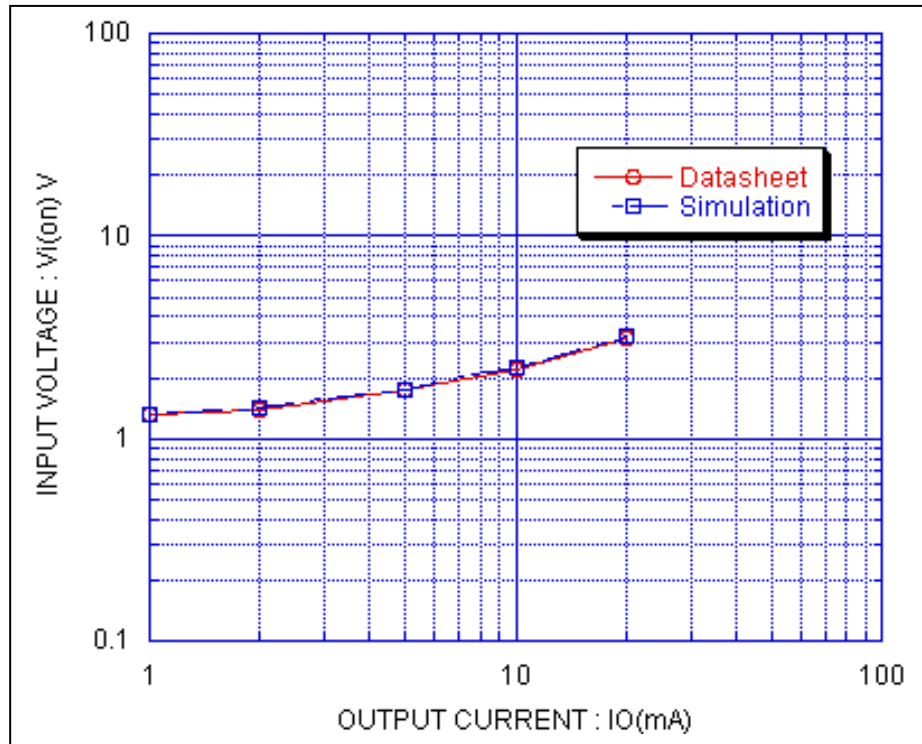

Simulation Result

Condition @ $V_o = 0.2$ V

I_o (A)	$V_{I(ON)}$ (V)		Error (%)
	Datasheet	Simulation	
100u	1.1	1.12	1.818
200u	1.15	1.16	0.869
500u	1.2	1.22	1.666
1m	1.3	1.32	1.538
2m	1.4	1.43	2.142
5m	1.75	1.75	0
10m	2.2	2.22	0.909
20m	3.1	3.18	2.58

Output current vs. input voltage (OFF characteristics)

Circuit simulation result

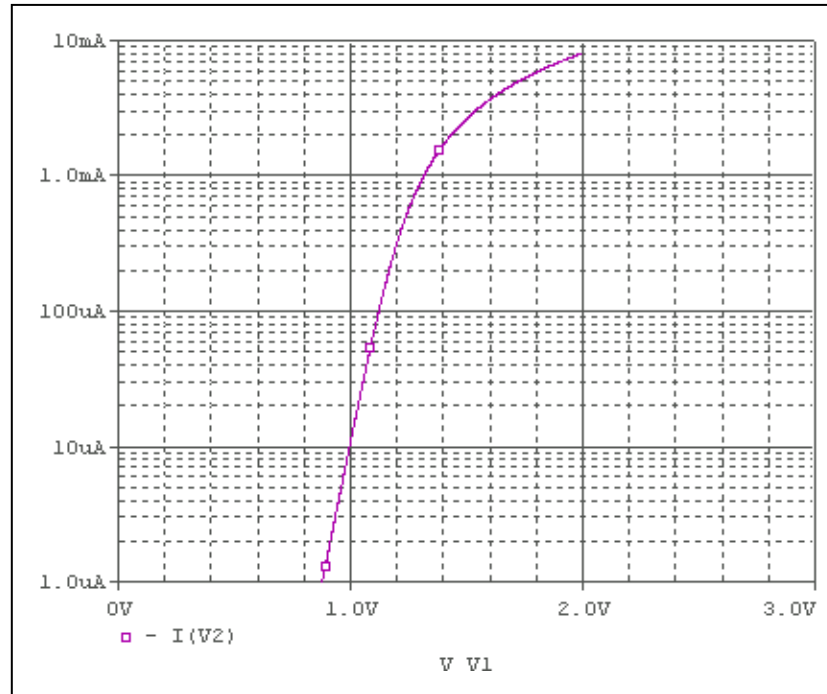

Evaluation circuit

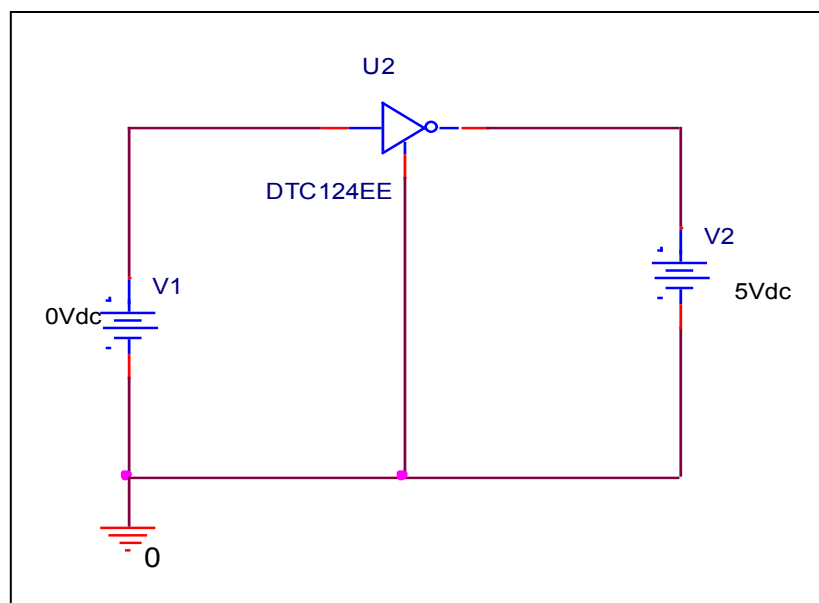

Comparison Graph

Circuit Simulation Result

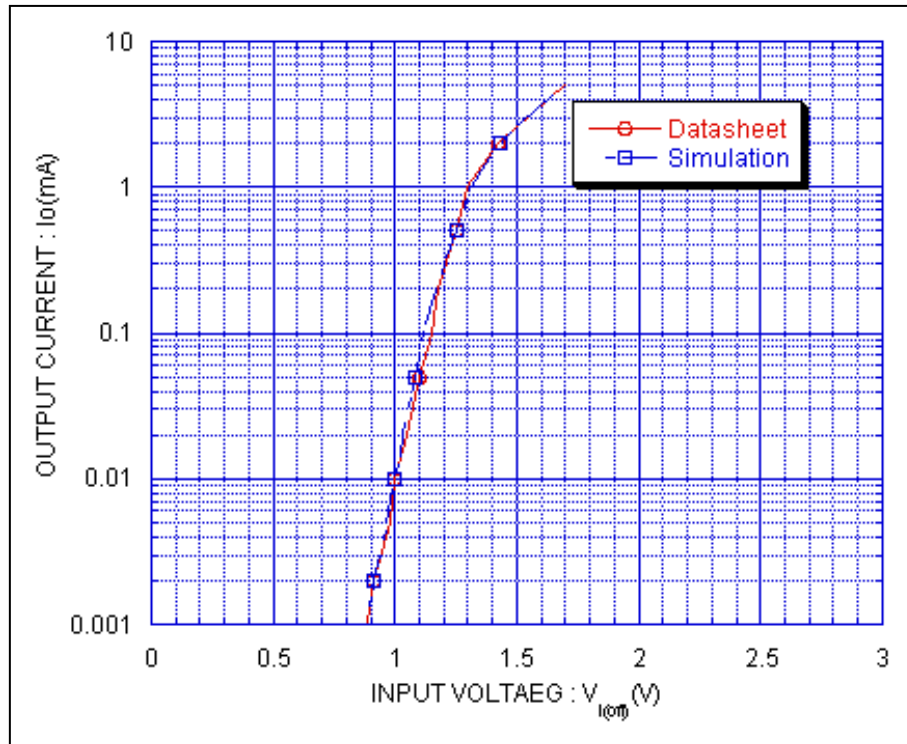

Simulation Result

Condition @ $V_{CC} = 5\text{ V}$

I_o (A)	$V_{I(off)}$ (V)		Error (%)
	Datasheet	Simulation	
1u	0.88	0.877	-0.34
2u	0.915	0.913	-0.218
5u	0.98	0.96	-2.04
10u	1	0.996	-0.4
20u	1.05	1.03	-1.904
50u	1.1	1.08	-1.818
100u	1.15	1.12	-2.608
200u	1.18	1.166	-1.186
500u	1.25	1.25	0
1m	1.3	1.31	0.769
2m	1.42	1.43	0.704
5m	1.7	1.7	0

DC current gain vs. output current

Circuit simulation result

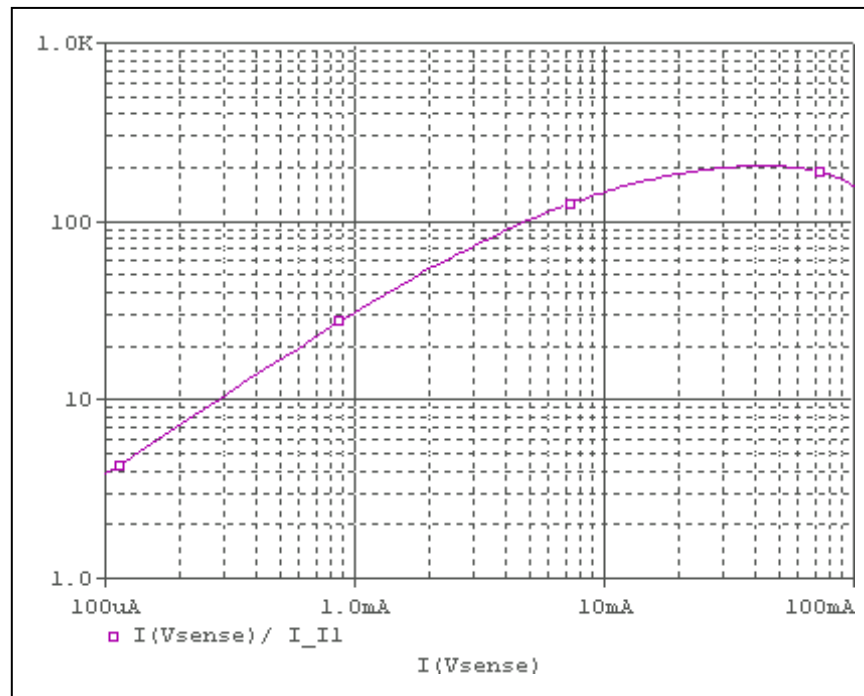

Evaluation circuit

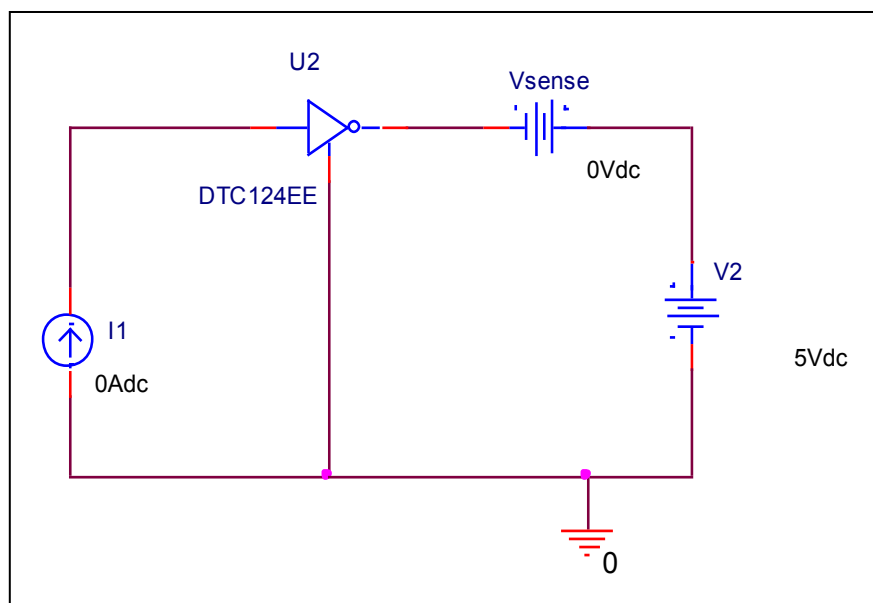

Comparison Graph

Circuit Simulation Result

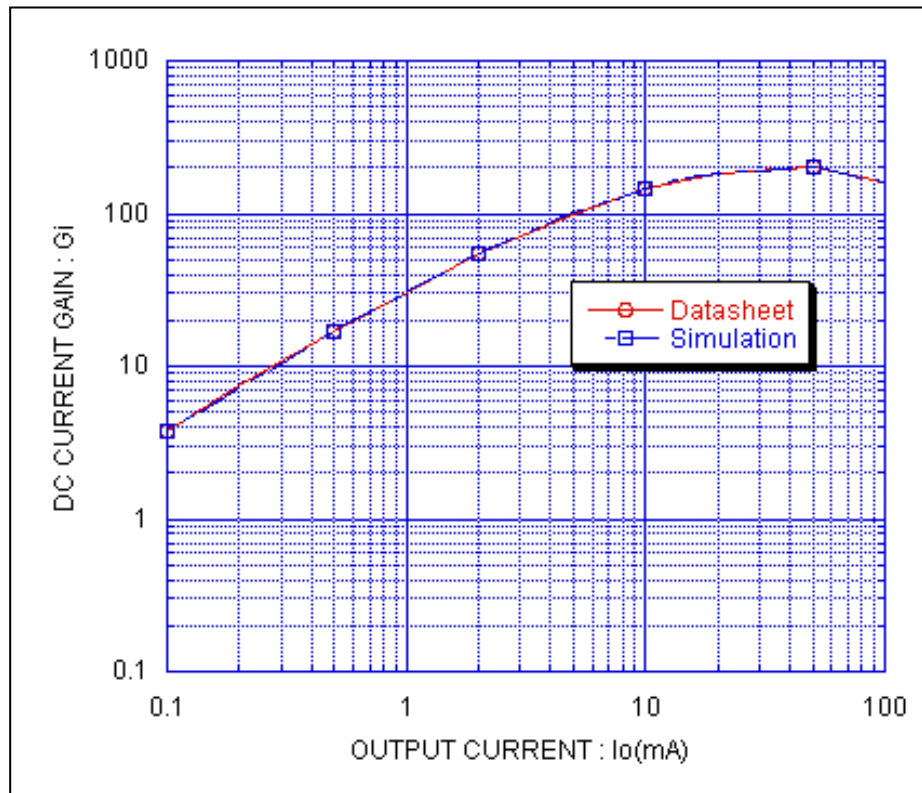

Simulation Result

Condition @ $V_{CC} = 5V$

$I_o(A)$	$V_{I(Off)} (V)$		Error (%)
	Datasheet	Simulation	
100u	3.8	3.81	0.263
200u	7.5	7.3	-2.666
500u	17	16.9	-0.588
1m	30	30.8	2.666
2m	55	54.3	-1.272
5m	100	102	2
10m	145	145.9	0.620
20m	185	185	0
50m	200	203	1.5
100m	155	154.6	-0.258

Output voltage VS. output current

Circuit simulation result

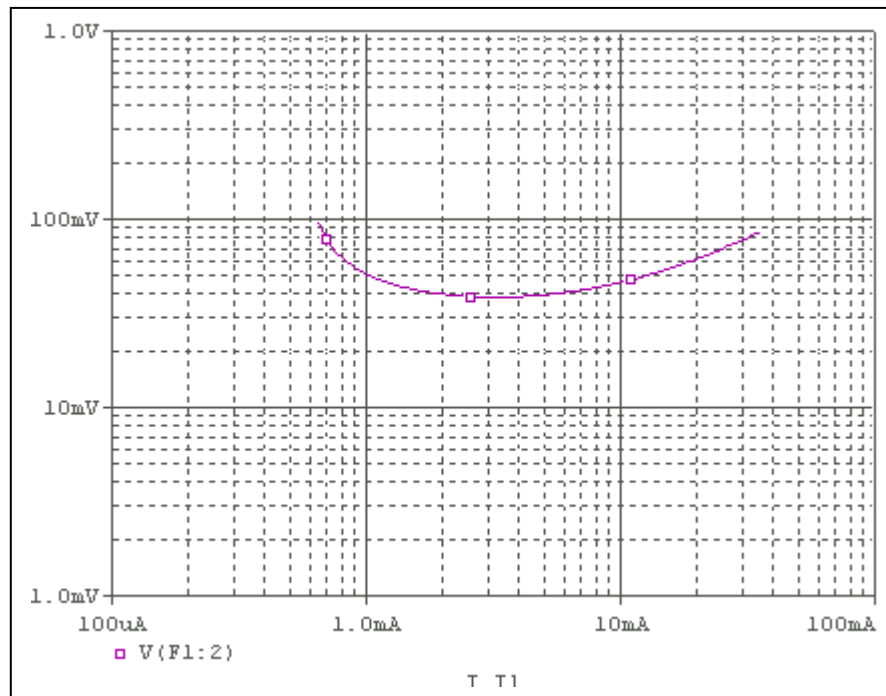

Evaluation circuit

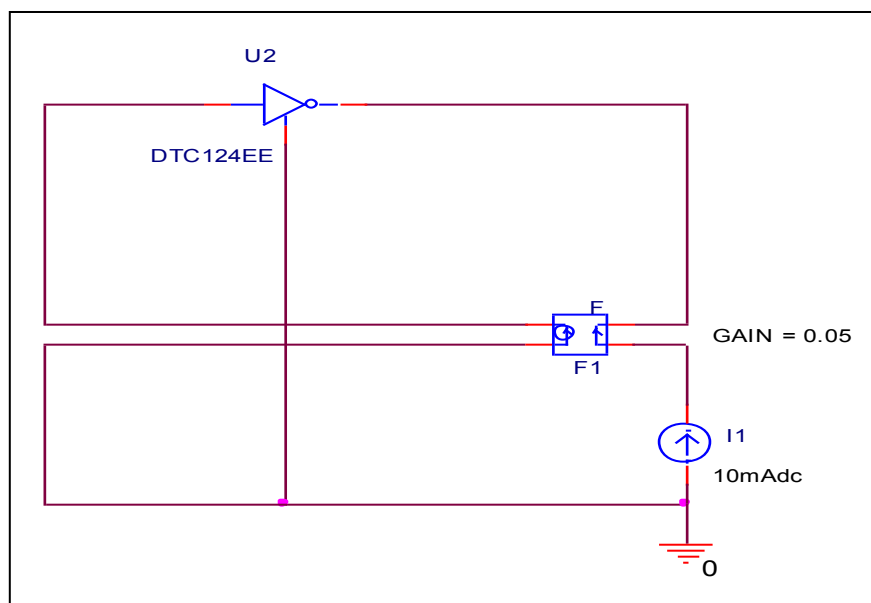

Comparison Graph

Circuit Simulation Result

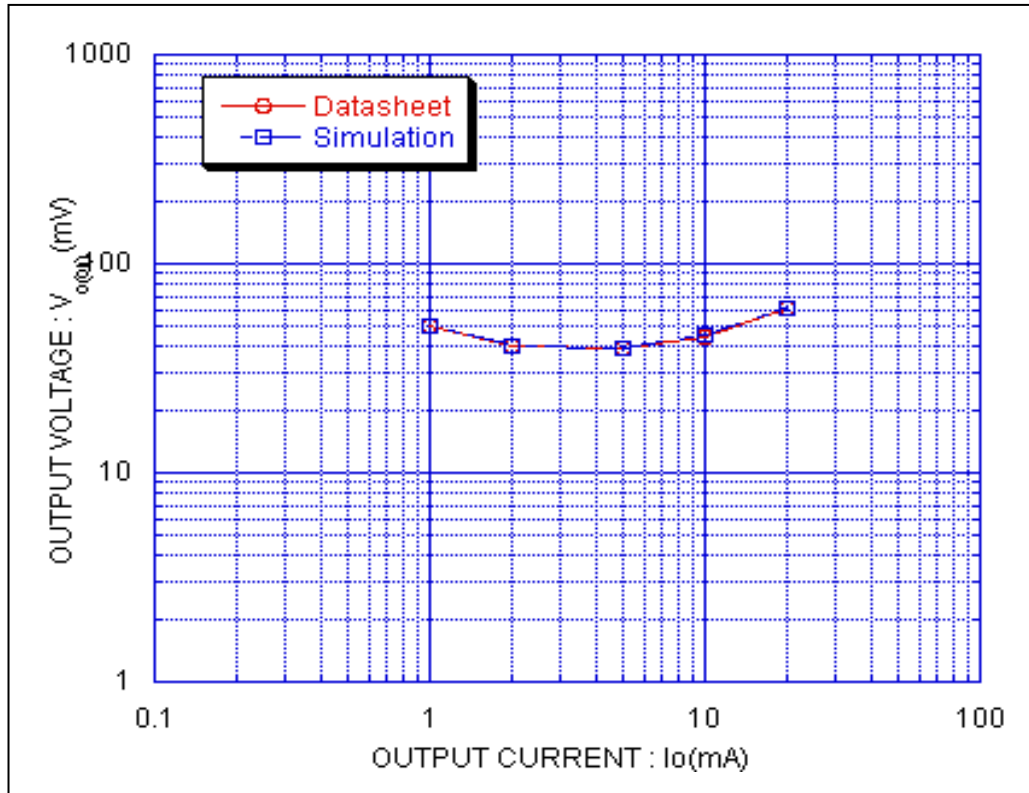

Simulation Result

Condition @ $I_o/I_i = 20$

Io(A)	V _{I(off)} (mV)		Error (%)
	Datasheet	Simulation	
1m	50	51.02	2.04
2m	40	39.98	-0.05
5m	39	39.6	1.538
10m	45	46.1	2.444
20m	61	61.5	0.819