

Device Modeling Report

COMPONENTS: Digital transistors (built-in resistors)
PART NUMBER: DTC124XM
MANUFACTURER: ROHM



Bee Technologies Inc

PSpice model parameter	Model description
IS	Saturation Current
BF	Ideal Maximum Forward Beta
NF	Forward Current Emission Coefficient
VAF	Forward Early Voltage
IKF	Forward Beta Roll-off Knee Current
ISE	Non-ideal Base-Emitter Diode Saturation Current
NE	Non-ideal Base-Emitter Diode Emission Coefficient
BR	Ideal Maximum Reverse Beta
NR	Reverse Emission Coefficient
VAR	Reverse Early Voltage
IKR	Reverse Beta Roll-off Knee Current
ISC	Non-ideal Base-Collector Diode Saturation Current
NC	Non-ideal Base-Collector Diode Emission Coefficient
NK	Forward Beta Roll-off Slope Exponent
RE	Emitter Resistance
RB	Base Resistance
RC	Series Collector Resistance
CJE	Zero-bias Emitter-Base Junction Capacitance
VJE	Emitter-Base Junction Potential
MJE	Emitter-Base Junction Grading Coefficient
CJC	Zero-bias Collector-Base Junction Capacitance
VJC	Collector-base Junction Potential
MJC	Collector-base Junction Grading Coefficient
FC	Coefficient for Onset of Forward-bias Depletion Capacitance
TF	Forward Transit Time
XTF	Coefficient for TF Dependency on Vce
VTF	Voltage for TF Dependency on Vce
ITF	Current for TF Dependency on Ic
PTF	Excess Phase at $f=1/2\pi*TF$
TR	Reverse Transit Time
EG	Activation Energy
XTB	Forward Beta Temperature Coefficient
XTI	Temperature Coefficient for IS

Input voltage vs. output current (ON characteristics)

Circuit simulation result

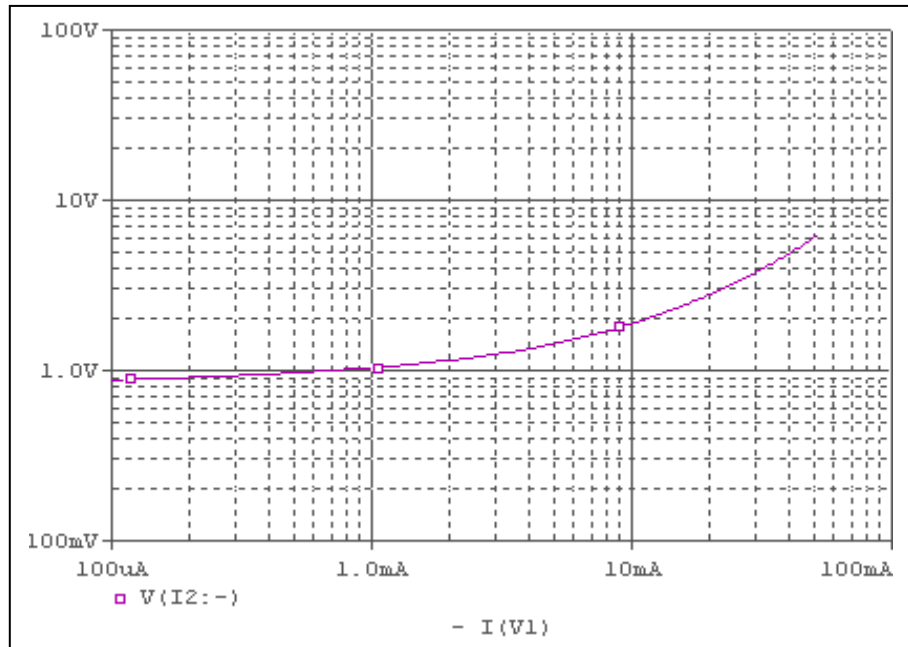

Evaluation circuit

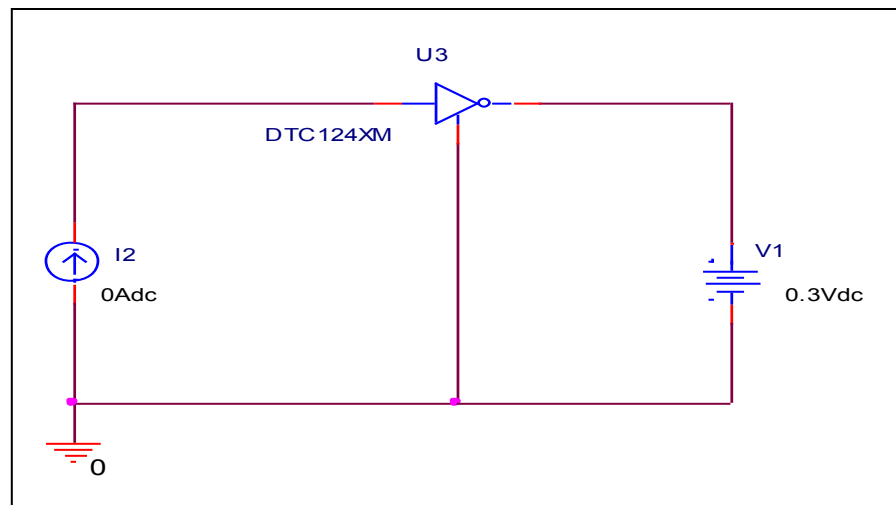

Comparison Graph

Circuit Simulation Result

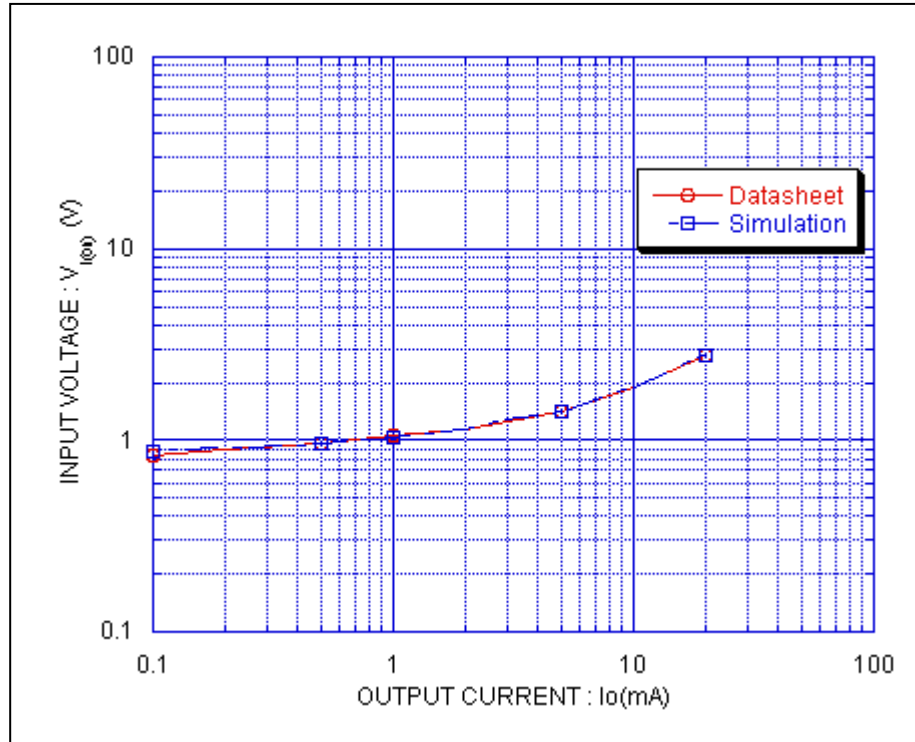

Simulation Result

Condition @ $V_o = 0.3$ V

I_o (A)	$V_{I(ON)}$ (V)		Error (%)
	Datasheet	Simulation	
100u	0.84	0.872	3.809
200u	0.89	0.907	1.91
500u	0.96	0.969	0.937
1m	1.05	1.03	-1.904
2m	1.15	1.14	-0.869
5m	1.4	1.43	2.142
10m	1.9	1.88	-1.052
20m	2.8	2.8	0

Output current vs. input voltage (OFF characteristics)

Circuit simulation result

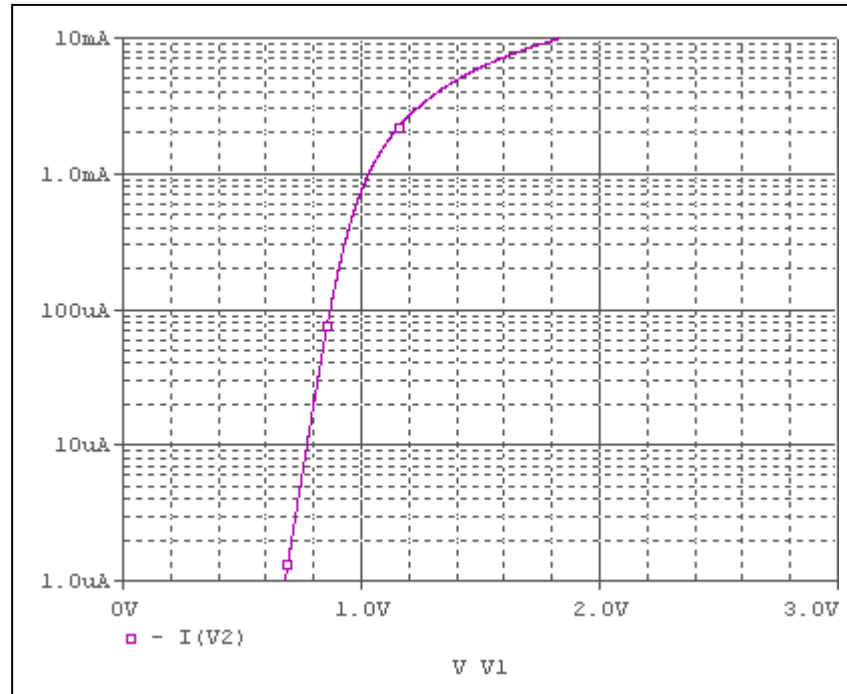

Evaluation circuit

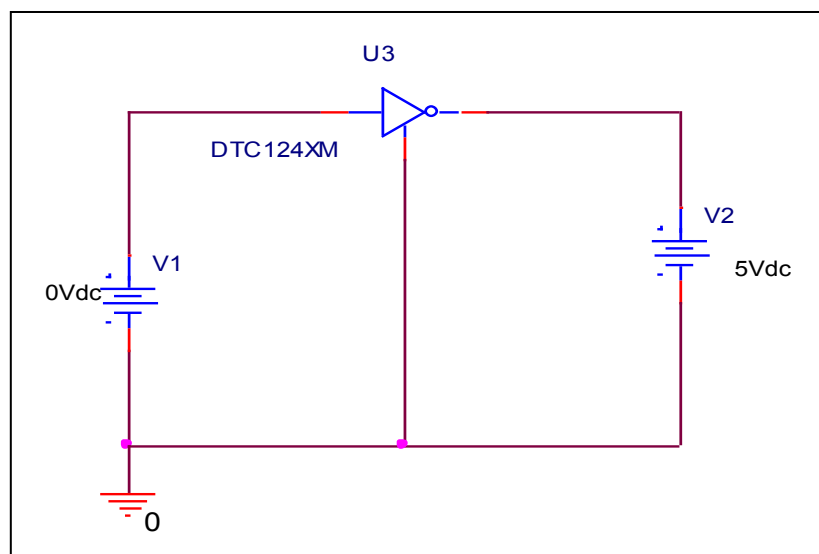

Comparison Graph

Circuit Simulation Result

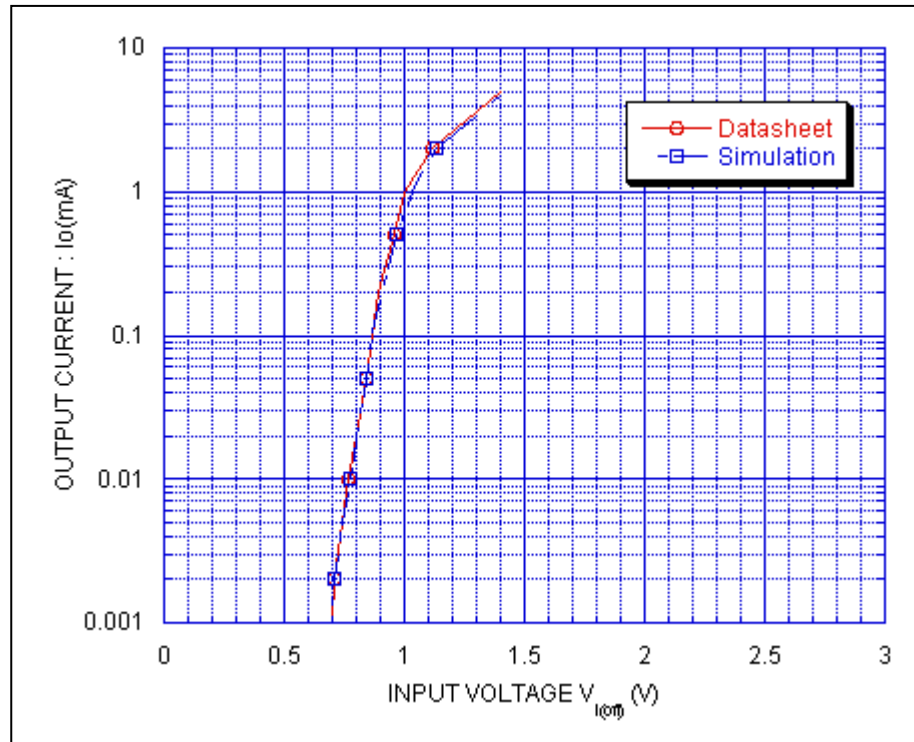

Simulation Result

Condition @ $V_{CC} = 5\text{ V}$

I_o (A)	$V_{I(off)}$ (V)		Error (%)
	Datasheet	Simulation	
1u	0.69	0.68	-1.449
2u	0.71	0.707	-0.422
5u	0.74	0.743	0.405
10u	0.77	0.772	0.259
20u	0.8	0.8	0
50u	0.84	0.839	-0.119
100u	0.87	0.869	-0.114
200u	0.89	0.907	1.91
500u	0.96	0.964	0.416
1m	1	1.03	3
2m	1.12	1.13	0.892
5m	1.4	1.414	1

DC current gain vs. output current

Circuit simulation result

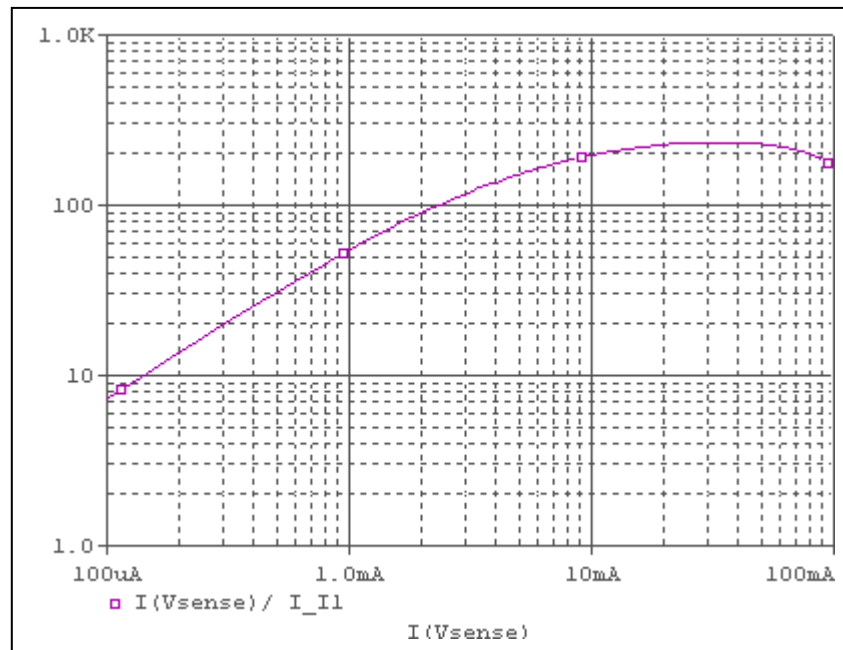

Evaluation circuit

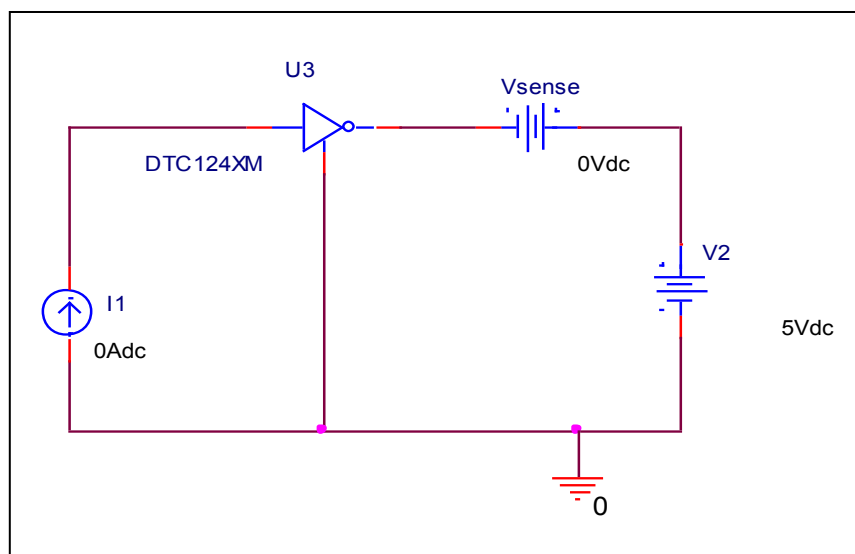

Comparison Graph

Circuit Simulation Result

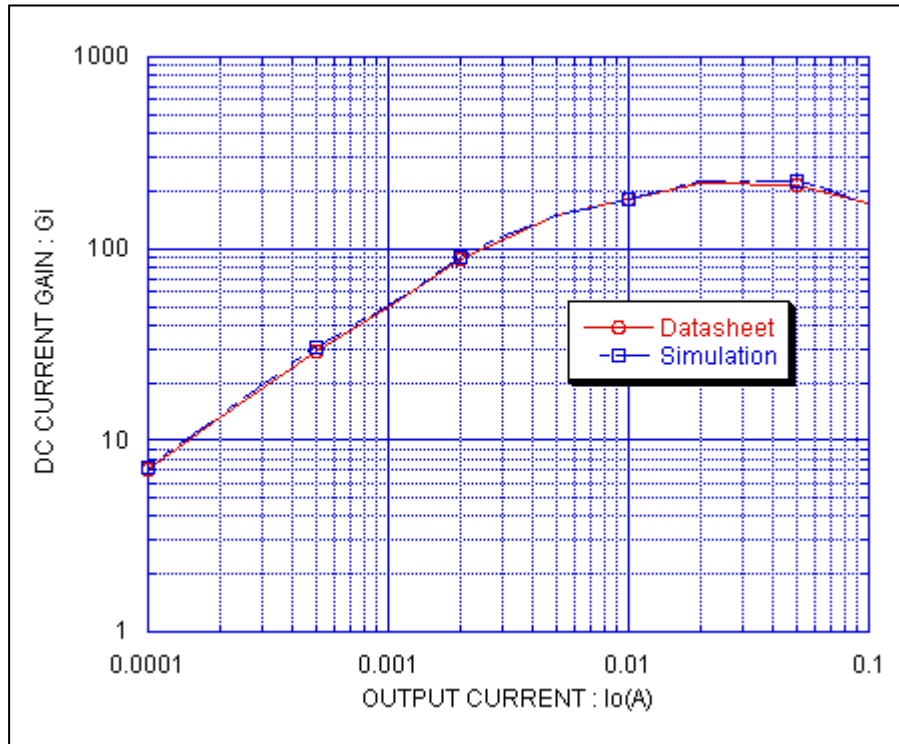

Simulation Result

Condition @ $V_{CC} = 5V$

Io(A)	$V_{I(Off)}$ (V)		Error (%)
	Datasheet	Simulation	
100u	7	7.25	3.571
200u	13	13.41	3.153
500u	29	30.22	4.206
1m	49	50.61	3.285
2m	87	90.51	4.034
5m	150	151.12	0.746
10m	170	169.19	-0.476
20m	220	226.88	3.127
50m	215	223.48	3.944
100m	170	167.43	-1.511

Output voltage VS. output current

Circuit simulation result

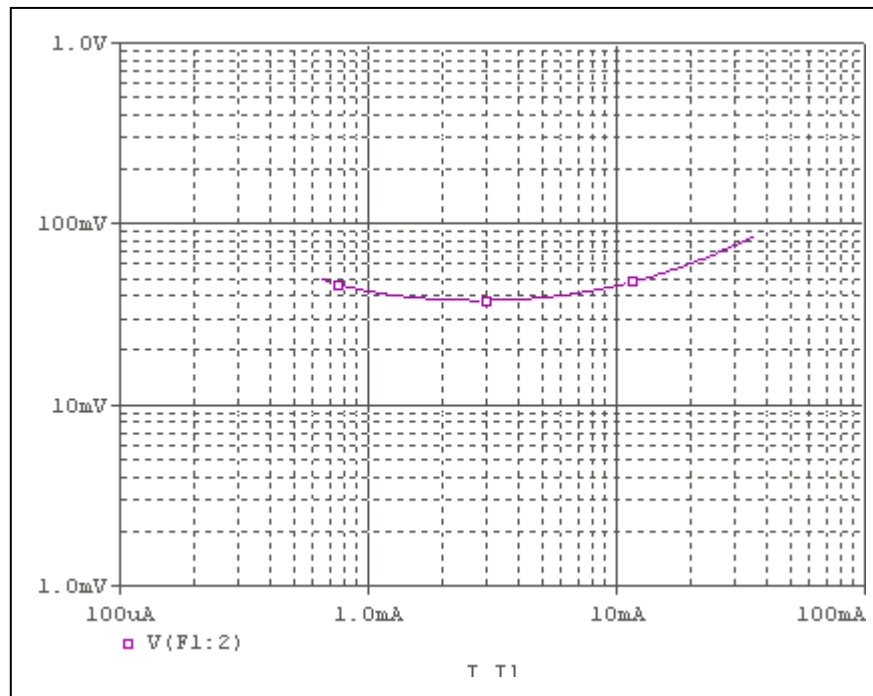

Evaluation circuit

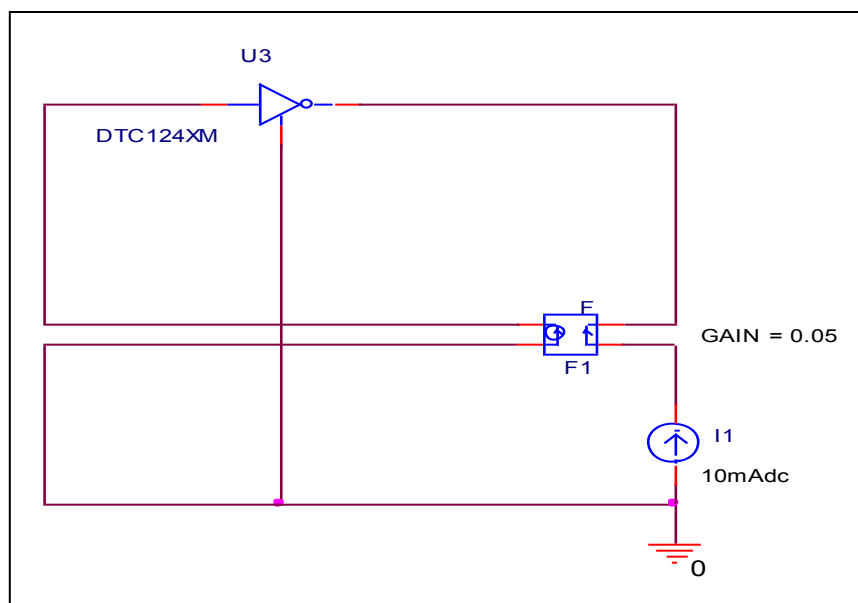

Comparison Graph

Circuit Simulation Result

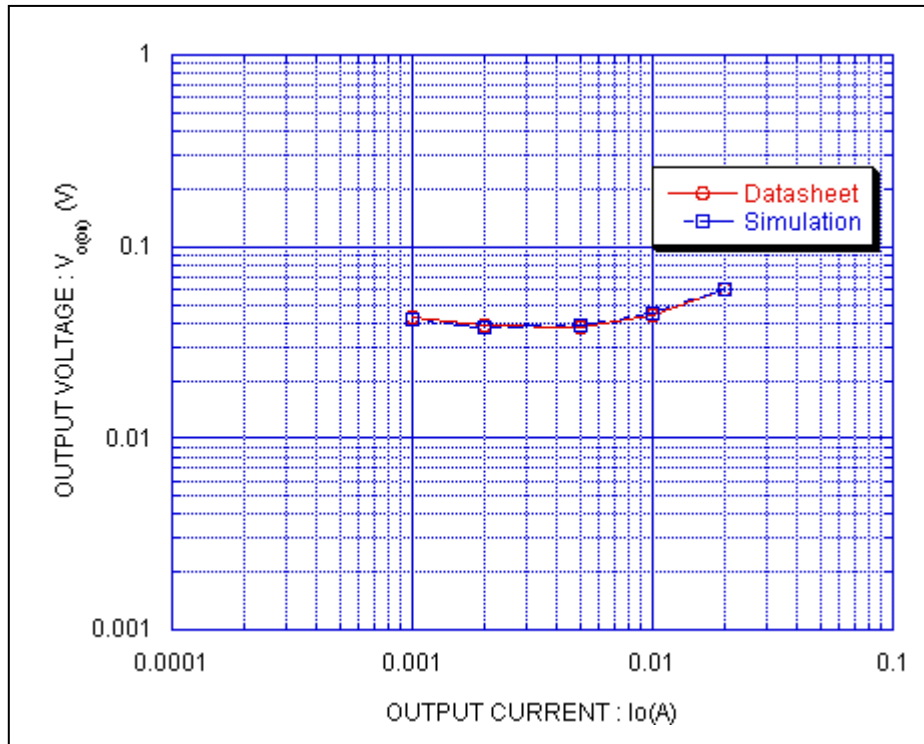

Simulation Result

Condition @ $I_o/I_i = 20$

I_o (A)	$V_{I(off)}$ (mV)		Error (%)
	Datasheet	Simulation	
1m	0.043	0.042	-2.325
2m	0.039	0.038	-2.564
5m	0.038	0.039	2.631
10m	0.044	0.045	2.272
20m	0.06	0.06	0