

Device Modeling Report

COMPONENTS: Lead-Acid Battery
PART NUMBER: MSE-150
MANUFACTURER: GS YUASA



Bee Technologies Inc.

Circuit Configuration

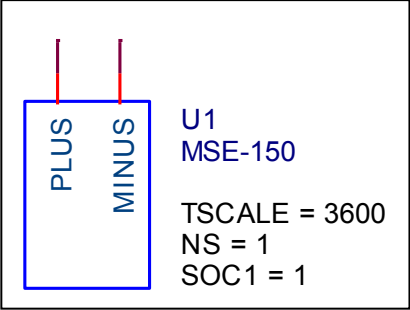

Discharge Characteristics

Circuit Simulation Result

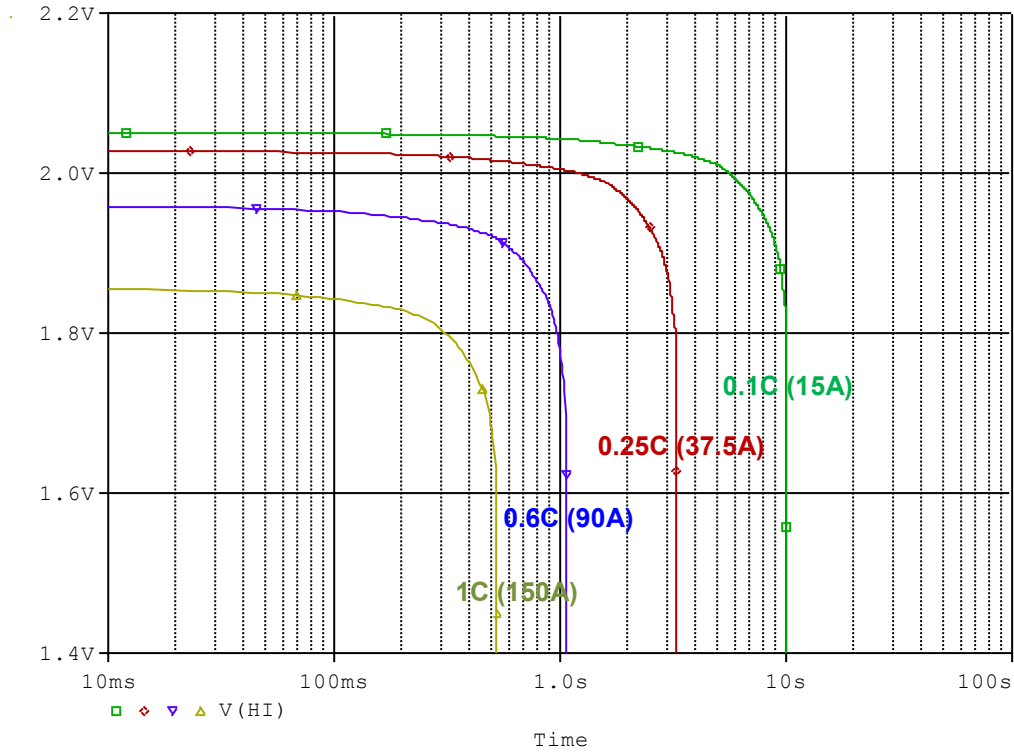

Simulation Circuit

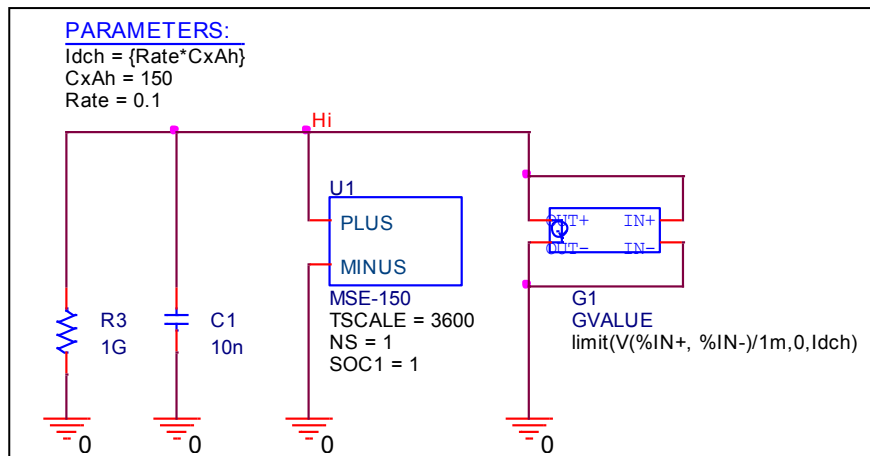

※ To discharge from 100% of battery capacity, SOC1=1

Charge Characteristics

Circuit Simulation Result

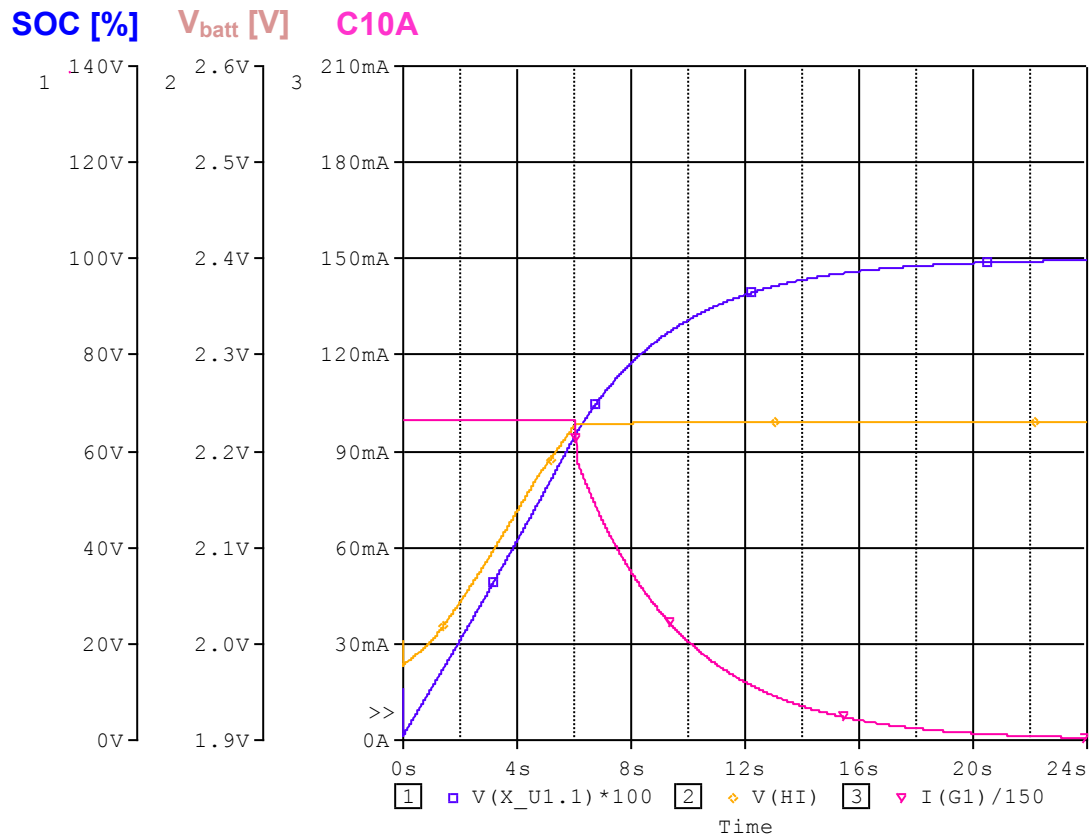

Simulation Circuit

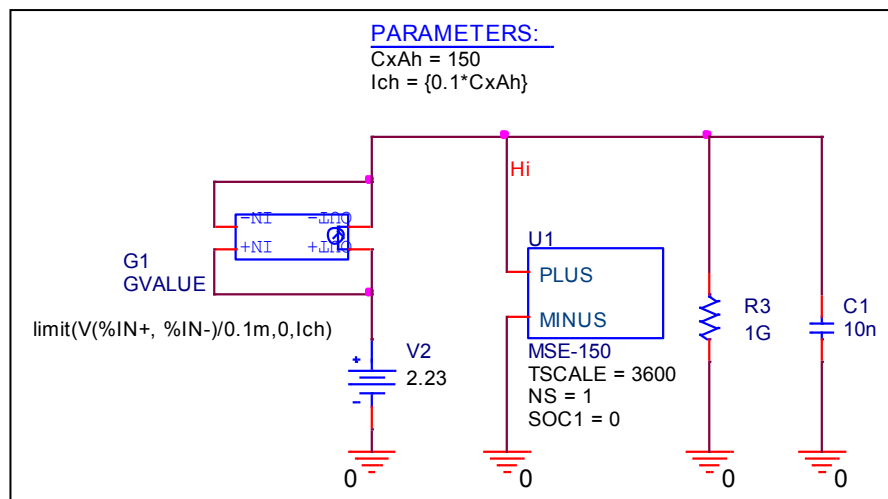

✗ To charge from 0% of battery capacity, SOC1=0

Data Information

No. MSE-150	
Nominal voltage	2.0 [Vdc]
Capacity	150[Ah]@C ₁₀ , 97.5[Ah]@C ₁
Rated charge	0.1C ₁₀ A
Input voltage	2.23 [Vdc]
Charging time	24 [hours] @0.1C ₁₀ A