

# Device Modeling Report

COMPONENTS : CMOS DIGITAL INTEGRATED CIRCUIT  
PART NUMBER : TC74ACT244F  
MANUFACTURER : TOSHIBA



**Bee Technologies Inc.**

# Truth Table

## Circuit simulation result

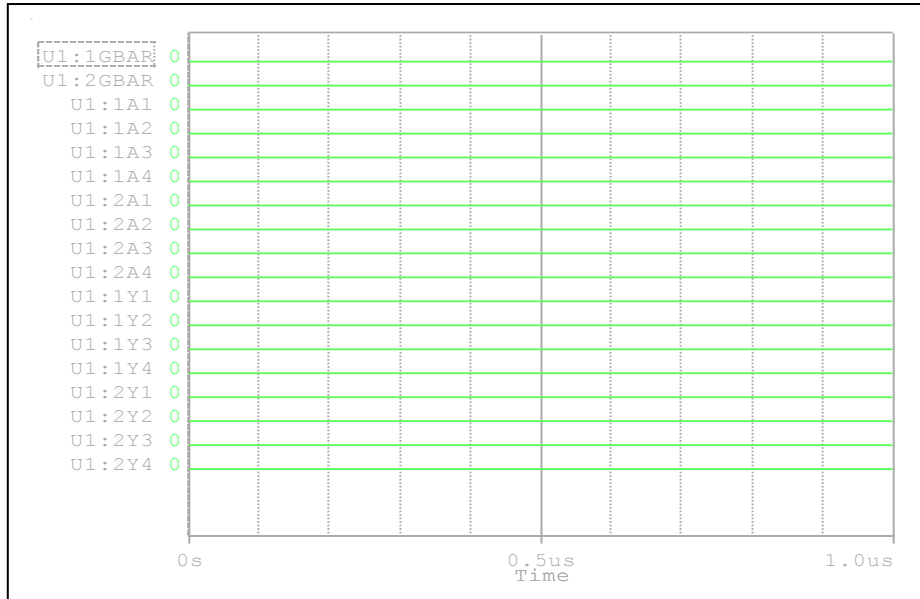

## Evaluation circuit

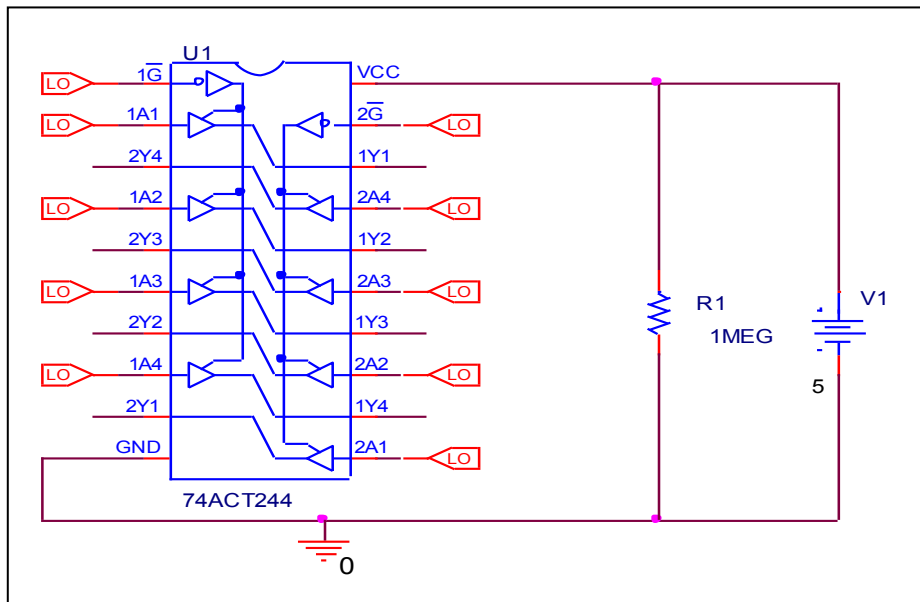

## Comparison table

Input		Output		%Error
$\overline{G}$	$A_n$	$Y_n$ (Measurement)	$Y_n$ (Simulation)	
L	L	L	L	0

# Truth Table

## Circuit simulation result

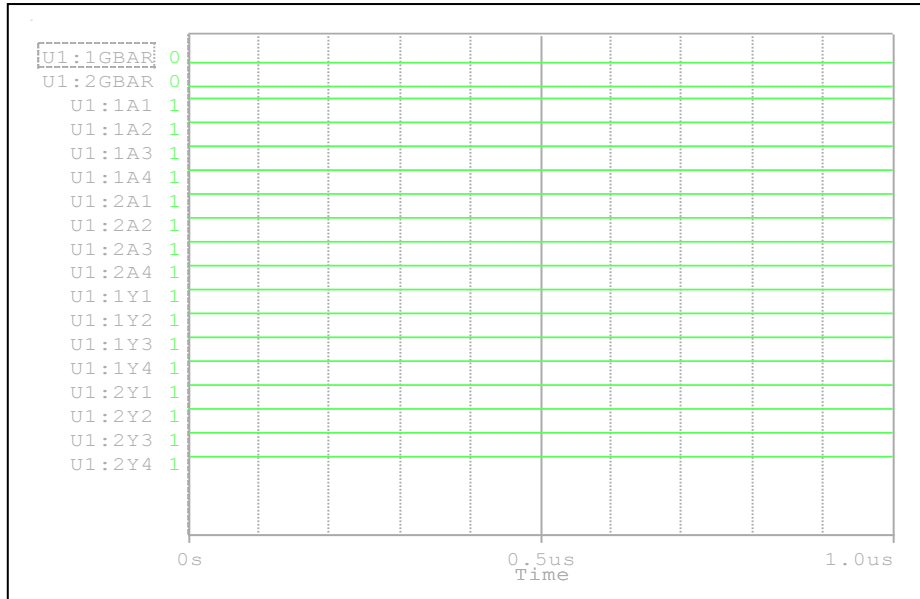

## Evaluation circuit

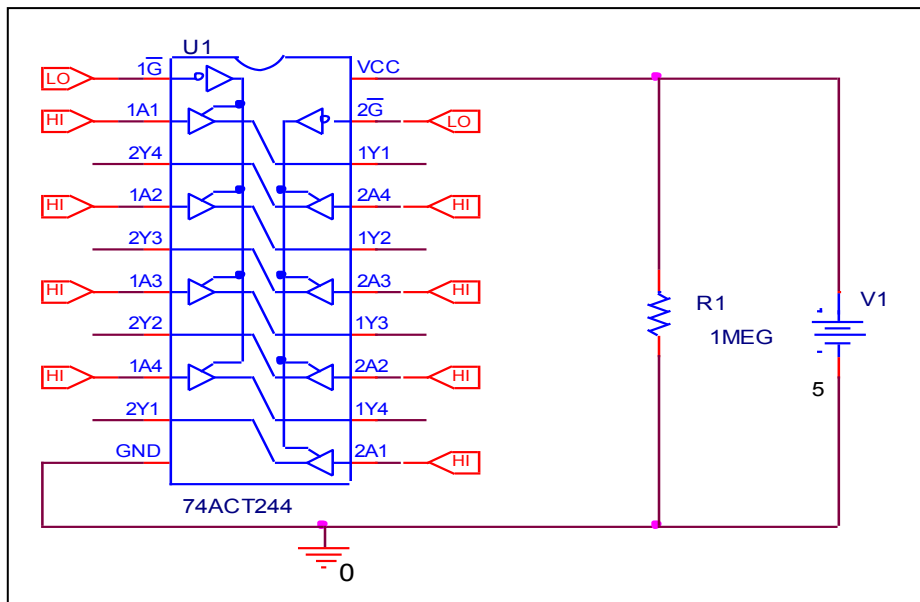

## Comparison table

Input		Output		%Error
$\bar{G}$	$A_n$	$Y_n$ (Measurement)	$Y_n$ (Simulation)	
L	H	H	H	0

# Truth Table

## Circuit simulation result

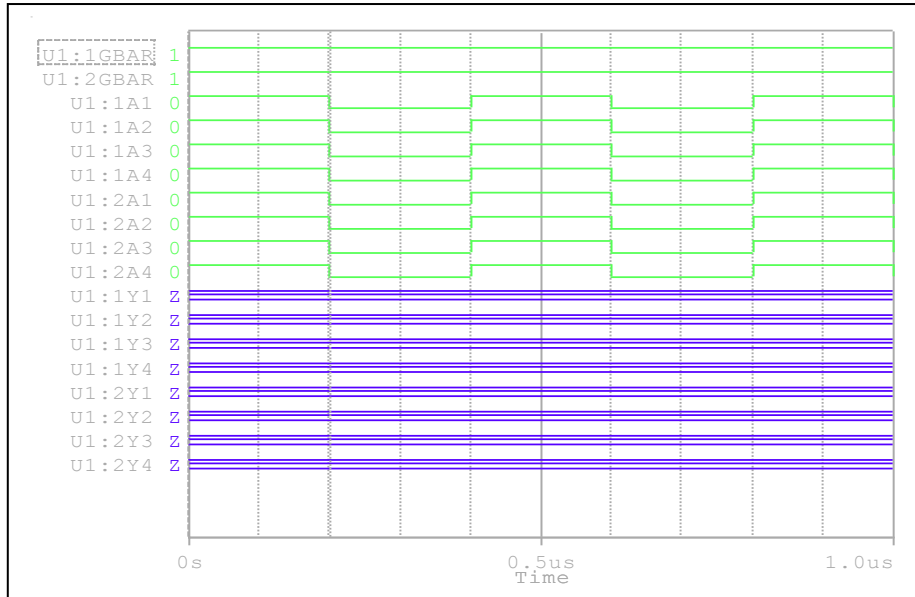

## Evaluation circuit

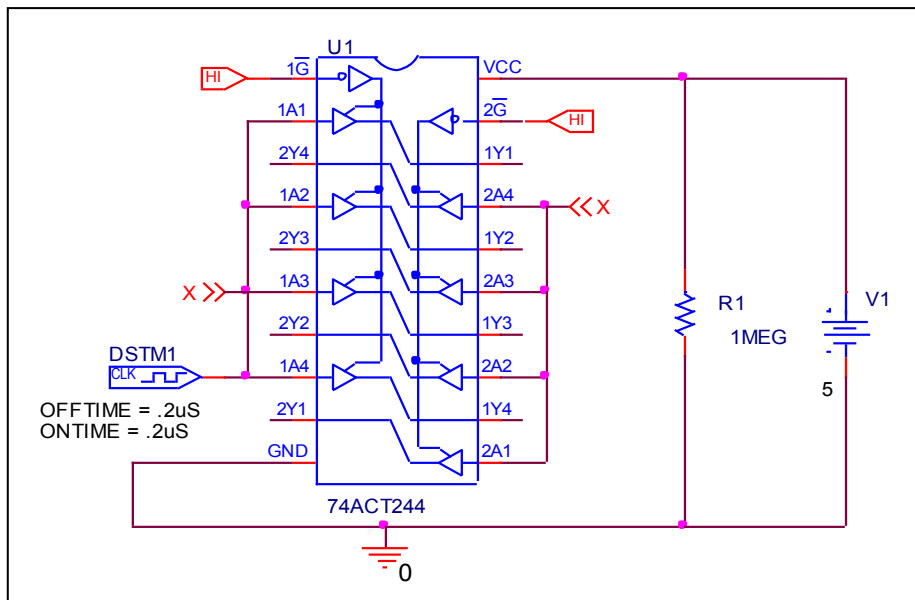

## Comparison table

Input		Output		%Error
$\bar{G}$	$A_n$	$Y_n$ (Measurement)	$Y_n$ (Simulation)	
H	X	Z	Z	0

# High Level and Low Level Input Voltage

## Circuit simulation result

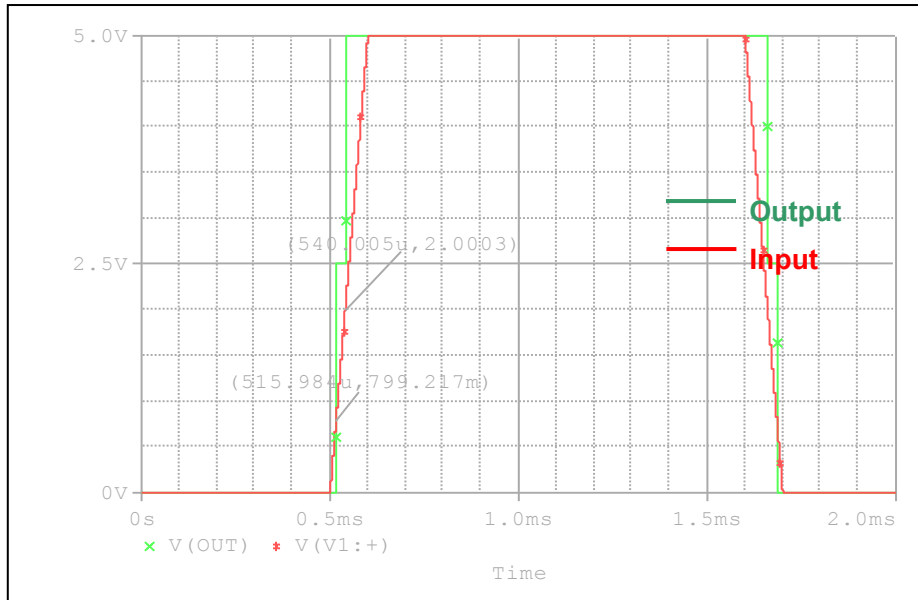

## Evaluation circuit

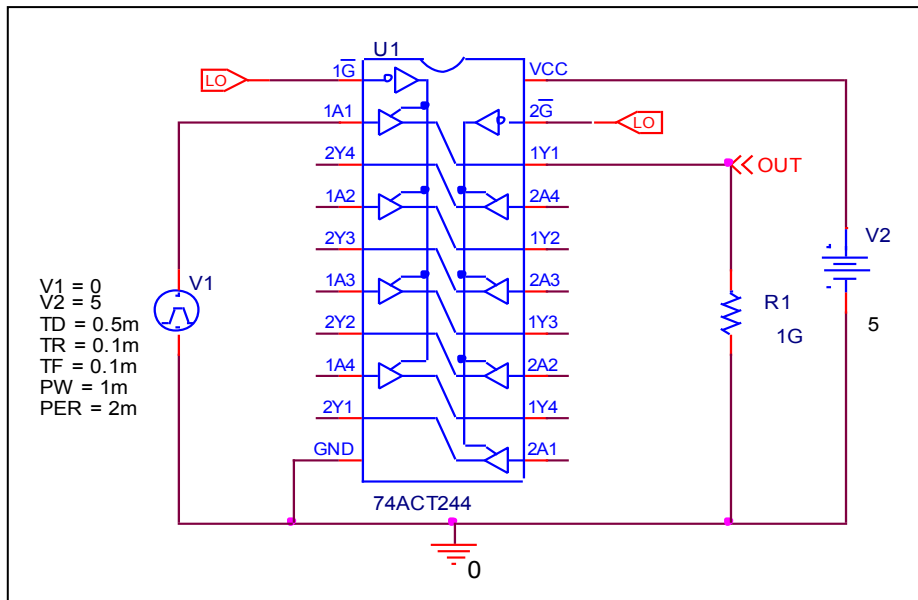

## Comparison table

V <sub>CC</sub> = 5V	Measurement	Simulation	%Error
V <sub>IH</sub> (V)	2	2	0
V <sub>IL</sub> (V)	0.8	0.799217	-0.098

# High Level and Low Level Output Voltage

## Circuit simulation result

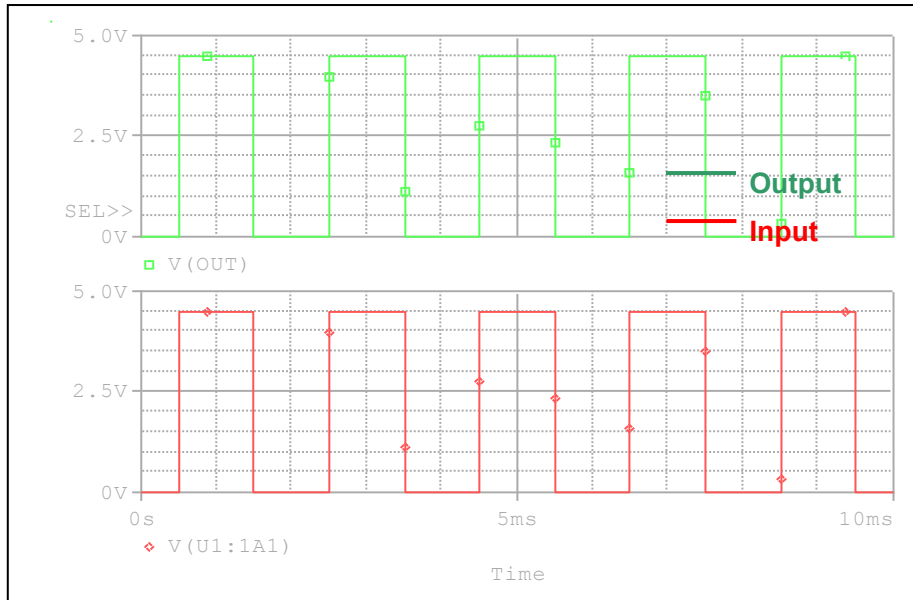

## Evaluation circuit

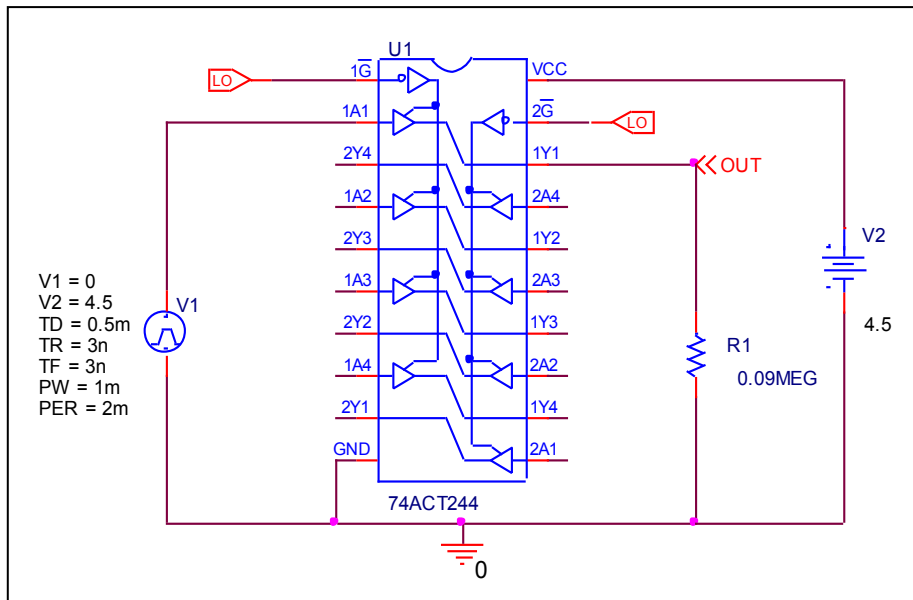

## Comparison table

$V_{CC} = 4.5V$	Measurement	Simulation	%Error
$V_{OH} (V)$	4.5	4.4988	-0.027
$V_{OL} (V)$	0	0	0

# Propagation Delay Time

## Circuit simulation result

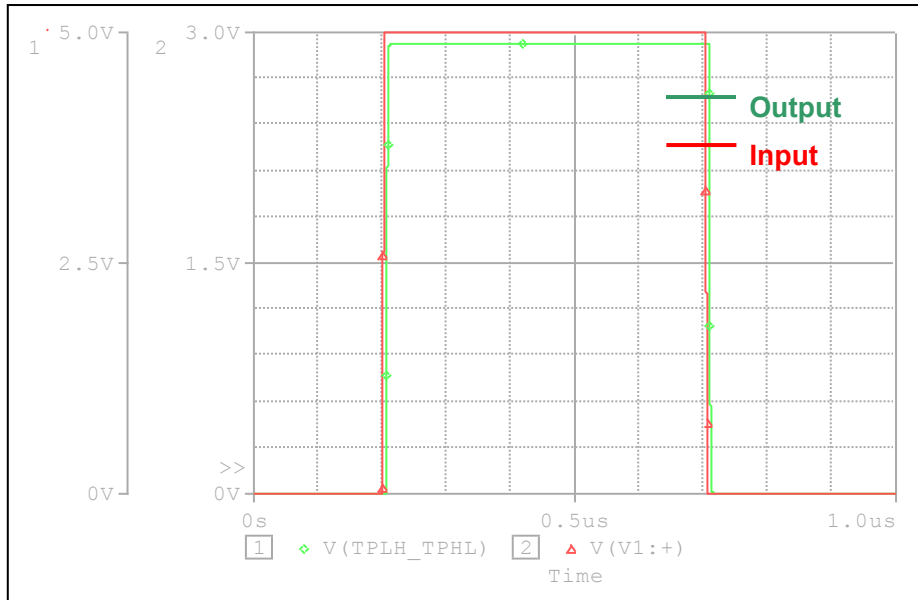

## Evaluation circuit

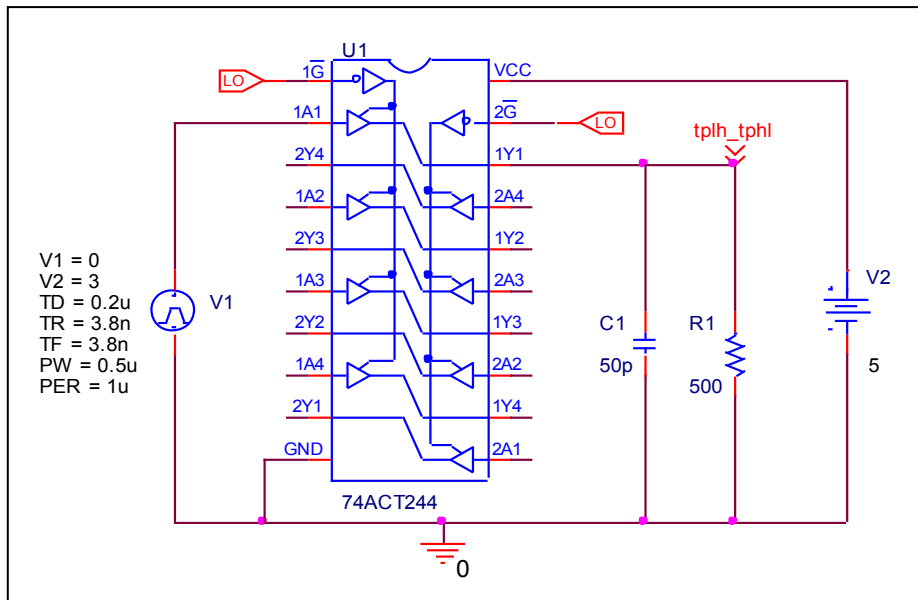

## Comparison table $C_L = 50 \text{ pF}$ , $R_L = 500 \text{ } \Omega$

$t_r = t_f = 3 \text{ ns}$	Measurement	Simulation	%Error
$t_{PLH} \text{ (ns)}$	5.7	5.8228	2.154
$t_{PHL} \text{ (ns)}$	5.7	5.7411	0.721

**Output enable time, high impedance (off) to high output ( $t_{PZH}$ )**  
**Output disable time, high to high impedance (off) output ( $t_{PHZ}$ )**

**Circuit simulation result**

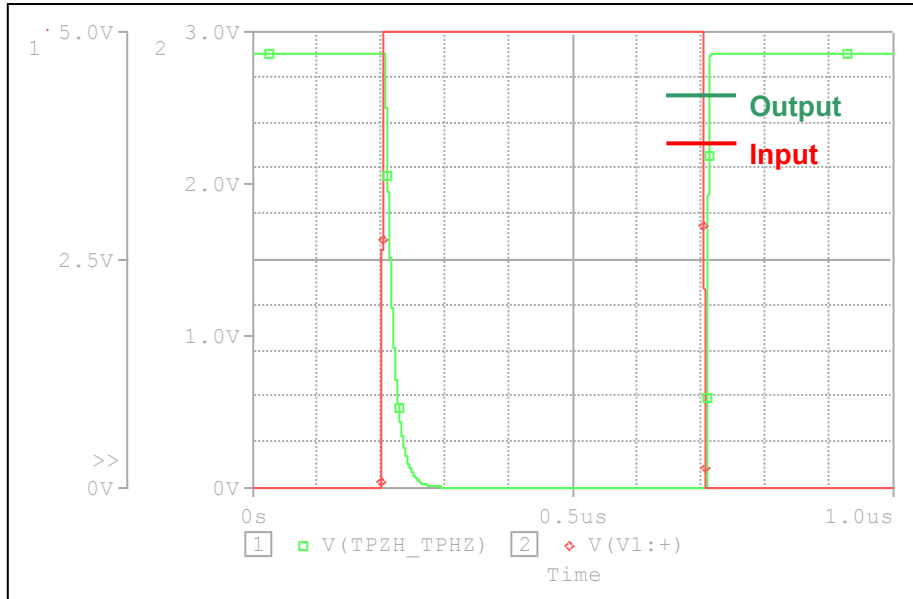

**Evaluation circuit**

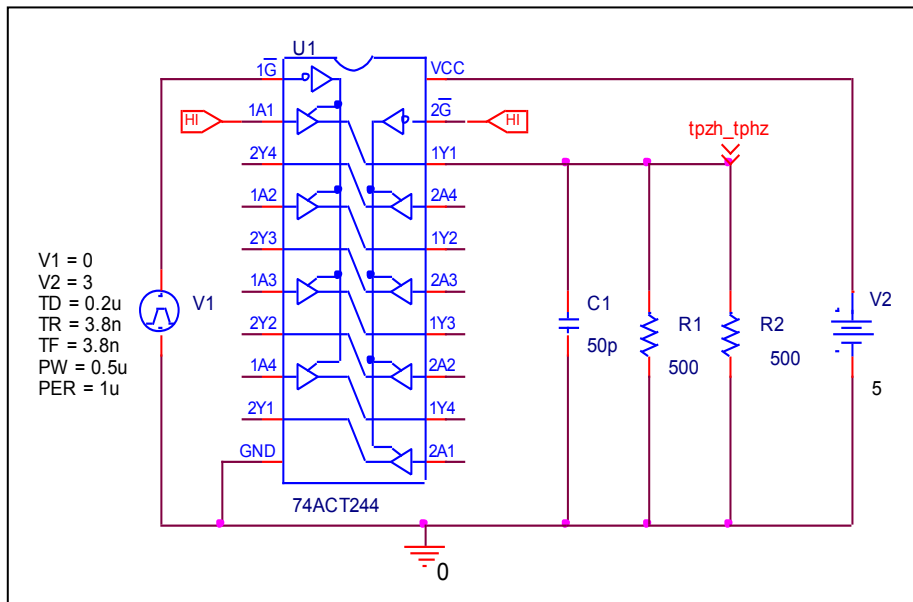

**Comparison table**  $C_L = 50 \text{ pF}$ ,  $R_L = 500 \Omega$

$t_r = t_f = 3 \text{ ns}$	Measurement	Simulation	%Error
$t_{PZH} \text{ (ns)}$	6	6.0132	0.220
$t_{PHZ} \text{ (ns)}$	5.9	5.9843	1.429

**Output enable time, high impedance (off) to low output ( $t_{PZL}$ )**  
**Output disable time, low to high impedance (off) output ( $t_{PLZ}$ )**

**Circuit simulation result**

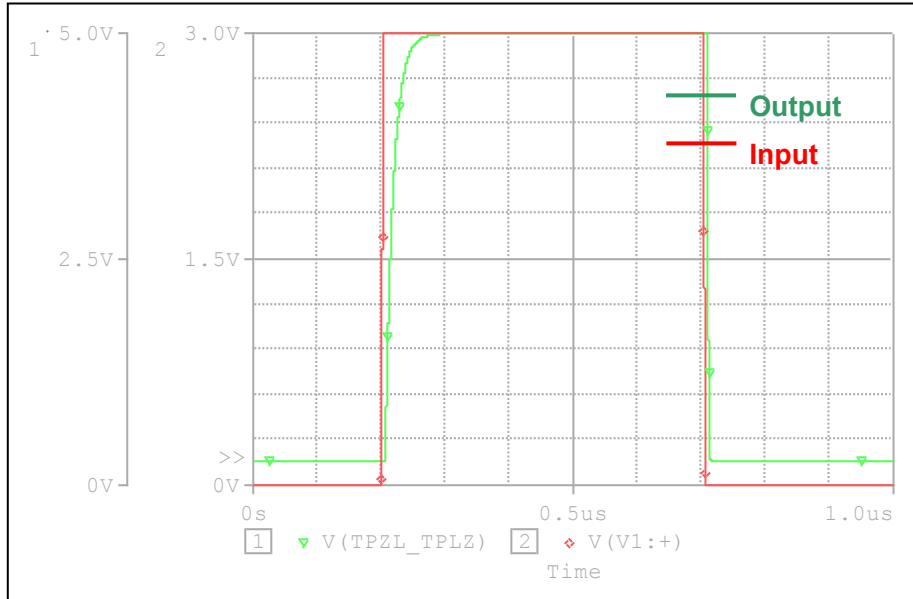

**Evaluation circuit**

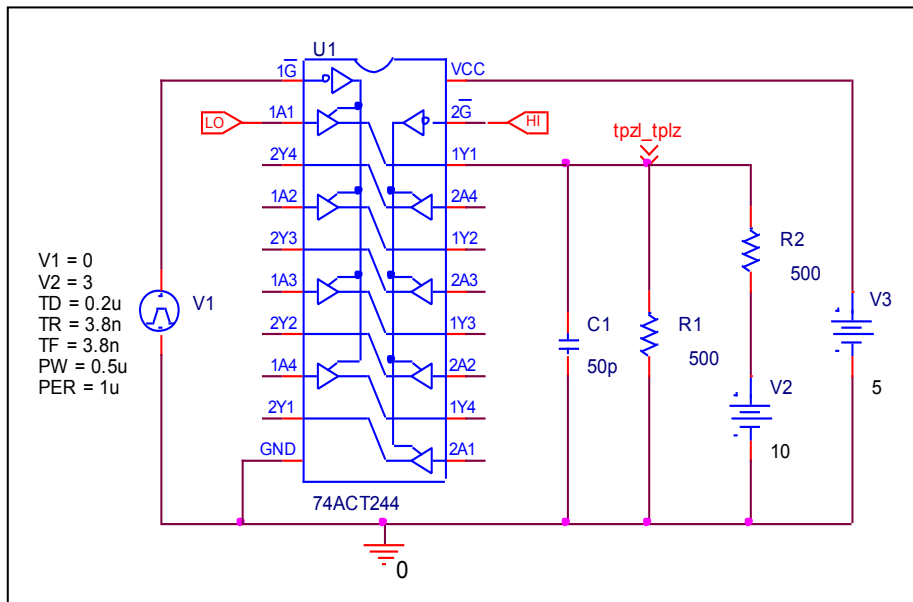

**Comparison table**  $C_L = 50 \text{ pF}$ ,  $R_L = 500 \Omega$

$t_r = t_f = 3 \text{ ns}$	Measurement	Simulation	%Error
$t_{PZL} \text{ (ns)}$	6	5.9928	-0.120
$t_{PLZ} \text{ (ns)}$	5.9	5.9245	0.415