

# Device Modeling Report

COMPONENTS: TRANSISTOR  
PART NUMBER: 2SC4331-AZ(K)  
MANUFACTURER: NEC



**Bee Technologies Inc.**

## TRANSISTOR MODEL

PSpice model parameter	Model description
IS	Saturation Current
BF	Ideal Maximum Forward Beta
NF	Forward Current Emission Coefficient
VAF	Forward Early Voltage
IKF	Forward Beta Roll-off Knee Current
ISE	Non-ideal Base-Emitter Diode Saturation Current
NE	Non-ideal Base-Emitter Diode Emission Coefficient
BR	Ideal Maximum Reverse Beta
NR	Reverse Emission Coefficient
VAR	Reverse Early Voltage
IKR	Reverse Beta Roll-off Knee Current
ISC	Non-ideal Base-Collector Diode Saturation Current
NC	Non-ideal Base-Collector Diode Emission Coefficient
NK	Forward Beta Roll-off Slope Exponent
RE	Emitter Resistance
RB	Base Resistance
RC	Series Collector Resistance
CJE	Zero-bias Emitter-Base Junction Capacitance
VJE	Emitter-Base Junction Potential
MJE	Emitter-Base Junction Grading Coefficient
CJC	Zero-bias Collector-Base Junction Capacitance
VJC	Collector-base Junction Potential
MJC	Collector-base Junction Grading Coefficient
FC	Coefficient for Onset of Forward-bias Depletion Capacitance
TF	Forward Transit Time
XTF	Coefficient for TF Dependency on Vce
VTF	Voltage for TF Dependency on Vce
ITF	Current for TF Dependency on Ic
PTF	Excess Phase at $f=1/2\pi*TF$
TR	Reverse Transit Time
EG	Activation Energy
XTB	Forward Beta Temperature Coefficient
XTI	Temperature Coefficient for IS

Reverse

### Reverse Early Voltage Characteristic

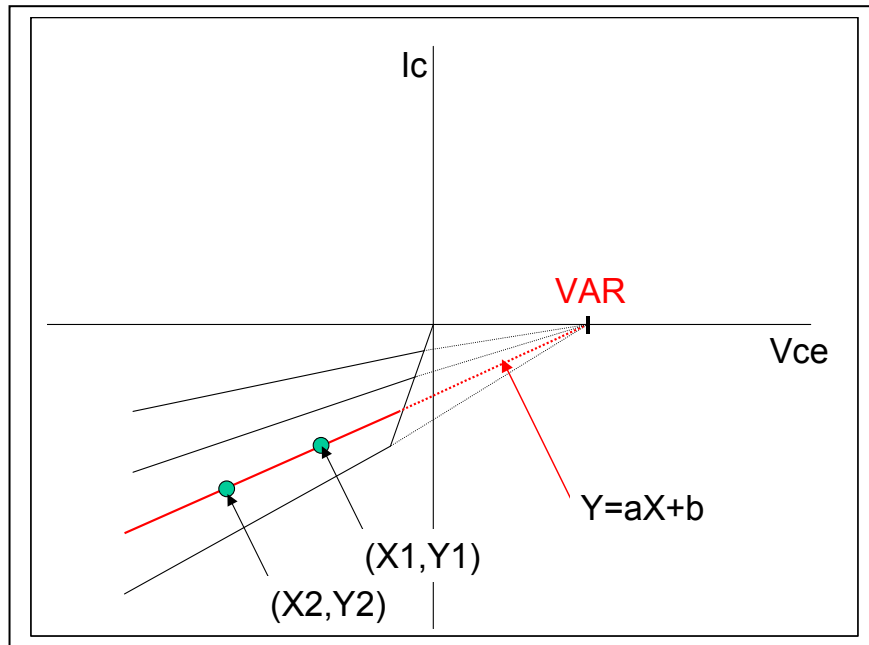
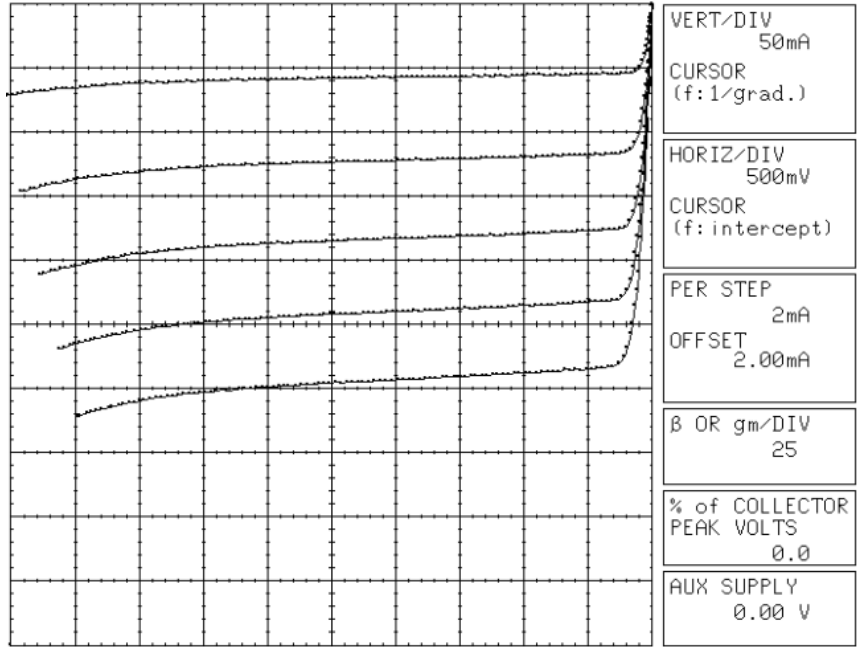

## Reverse DC Beta Characteristic (I<sub>e</sub> vs. h<sub>FE</sub>)

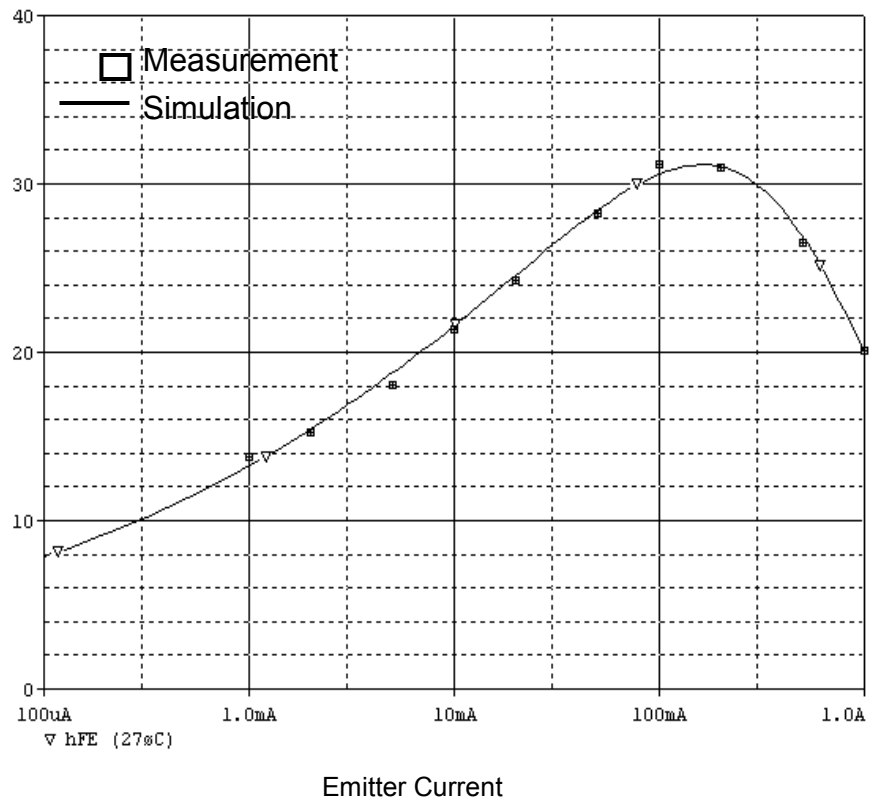

Forward

### Forward Early Voltage Characteristic

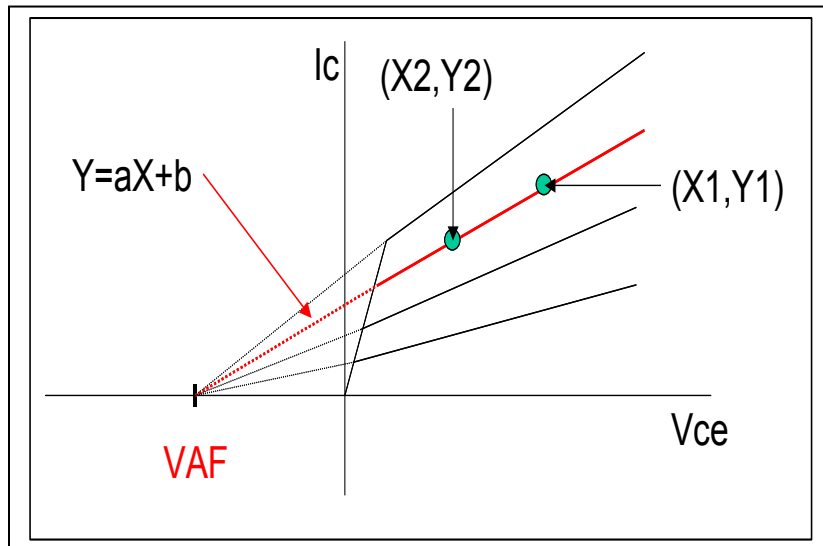
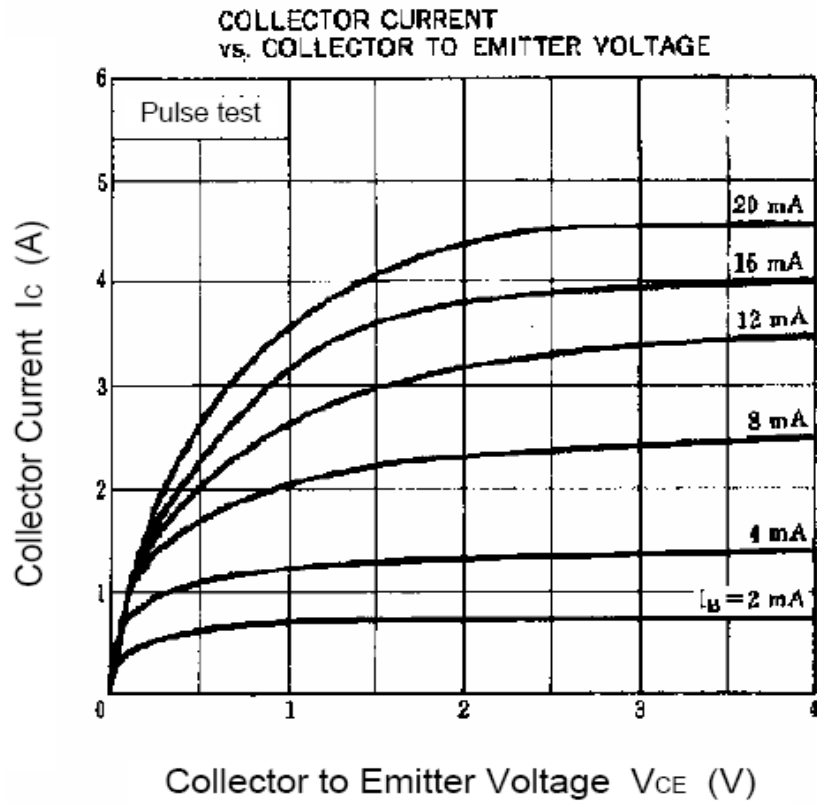

## C-B Capacitance Characteristics

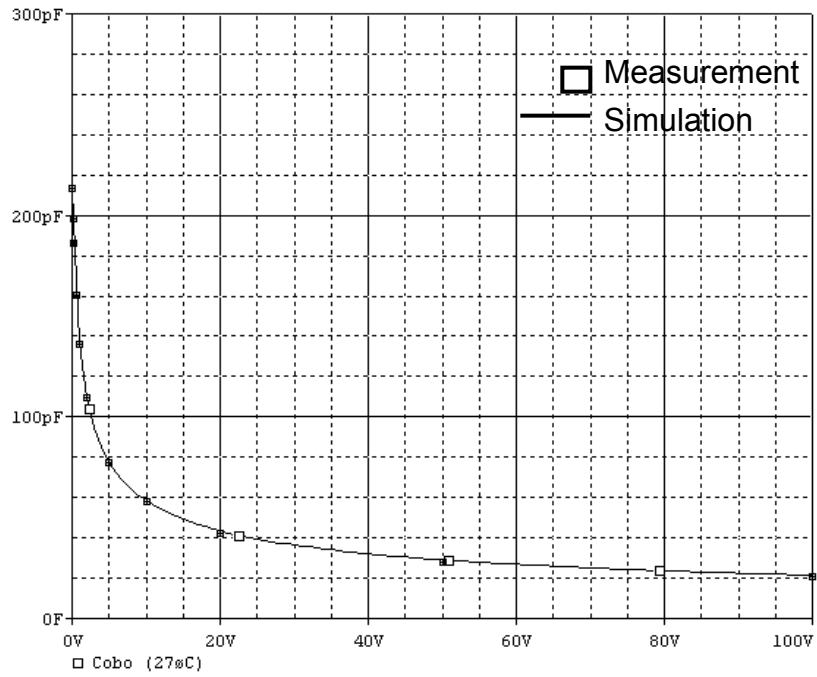

## E-B Capacitance Characteristics

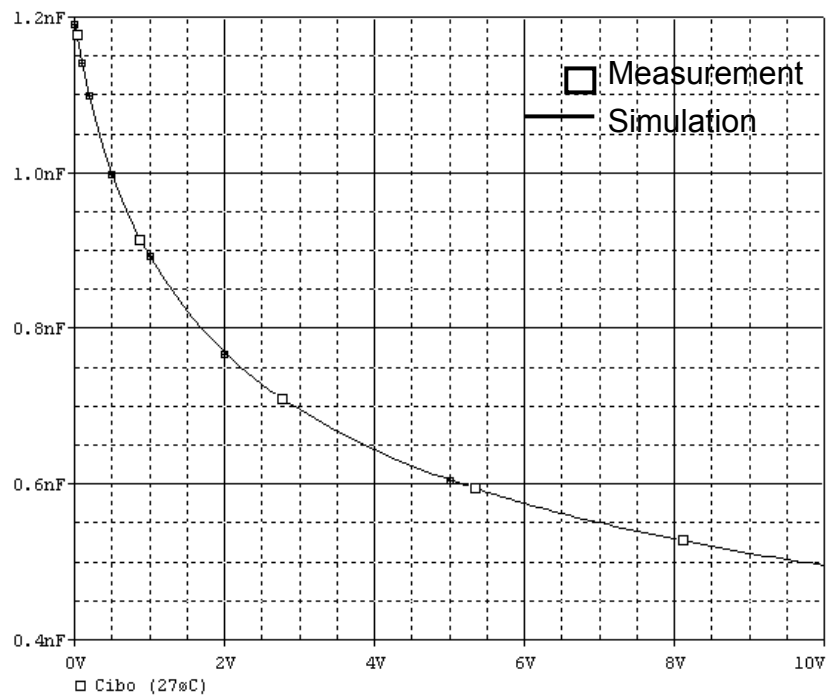

# Transistor $h_{FE}$ - $I_C$ Characteristics

## Circuit Simulation Result

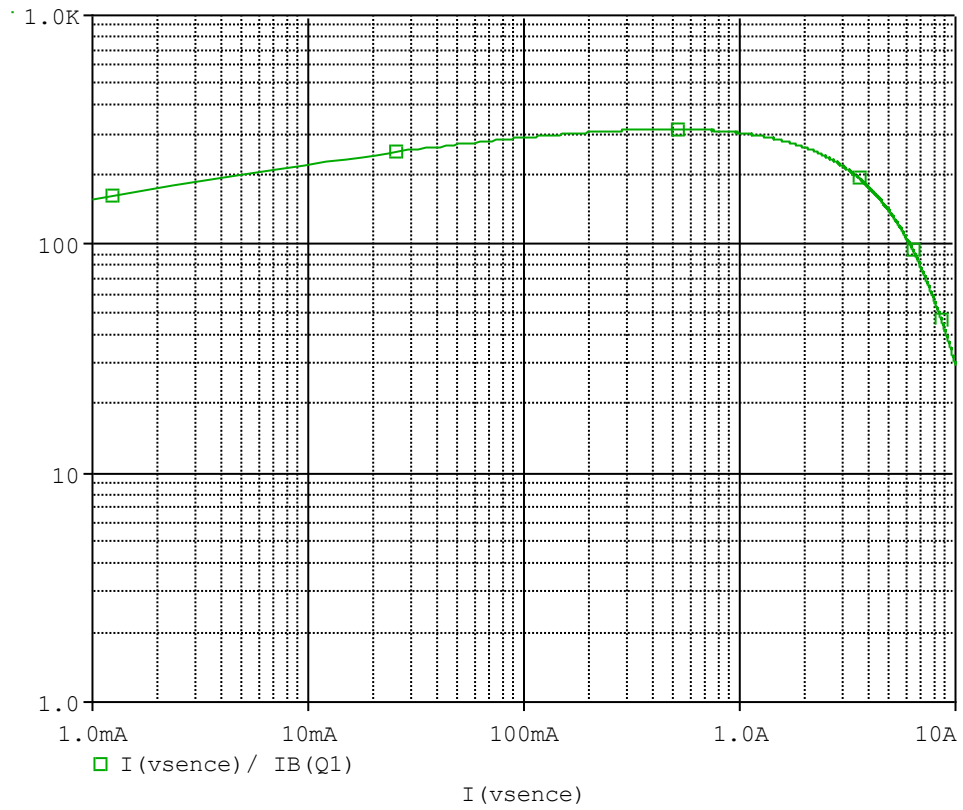

## Evaluation Circuit

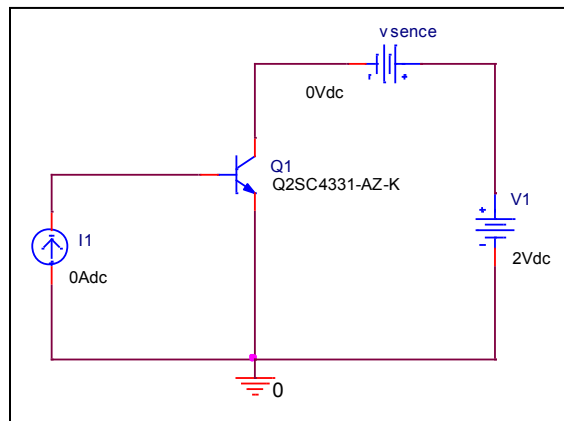

## Comparison Graph

### Circuit Simulation Result

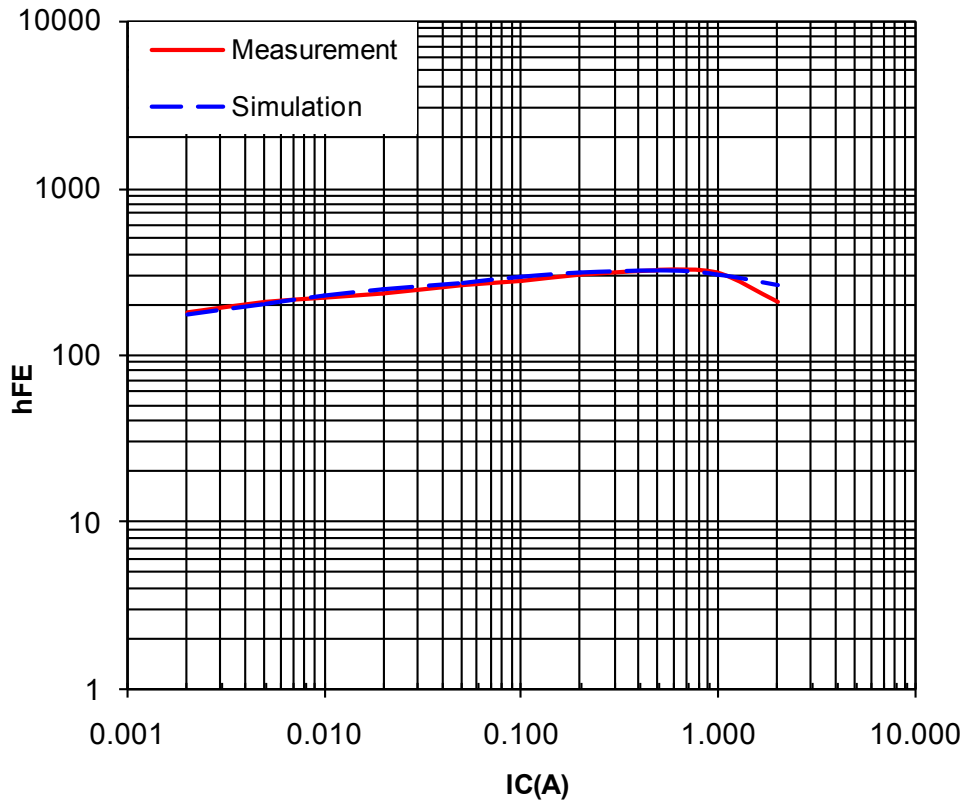

### Simulation Result

IC(A)	hFE		Error(%)
	Measurement	Simulation	
0.002	180.000	172.493	-4.171
0.005	205.000	202.727	-1.109
0.010	220.000	224.053	1.842
0.020	235.000	245.438	4.442
0.050	260.000	273.195	5.075
0.100	280.000	292.444	4.444
0.200	300.000	308.444	2.815
0.500	325.000	317.521	-2.301
1.000	310.000	306.763	-1.044



# $V_{CE(Sat)}$ - $I_C$ Characteristics

## Circuit Simulation Result

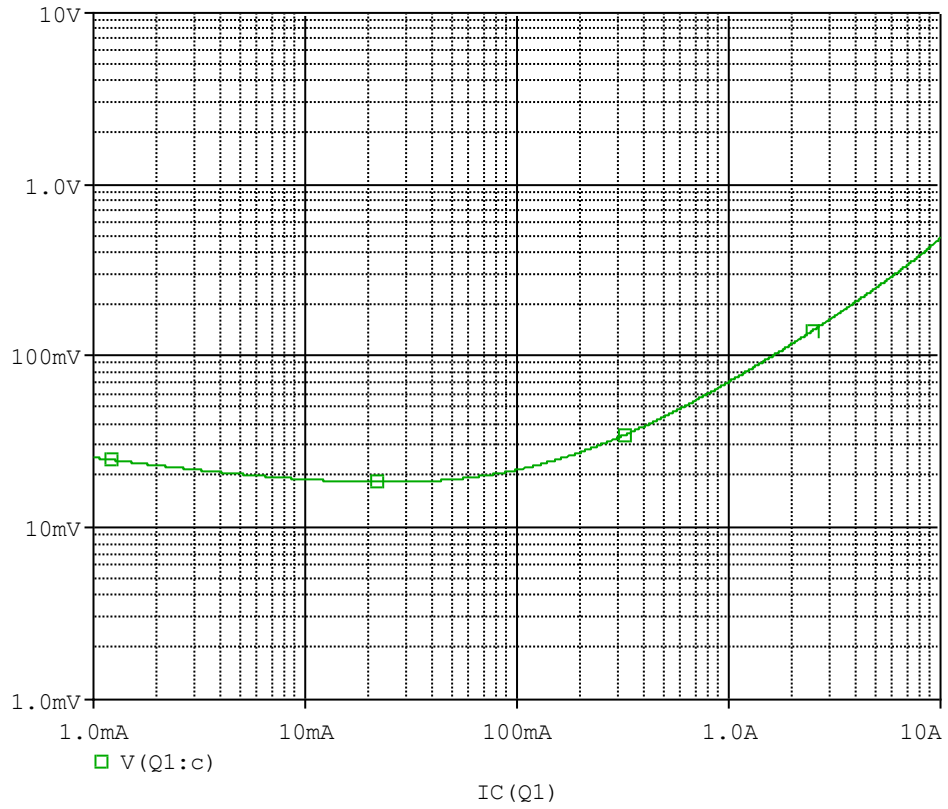

## Evaluation Circuit

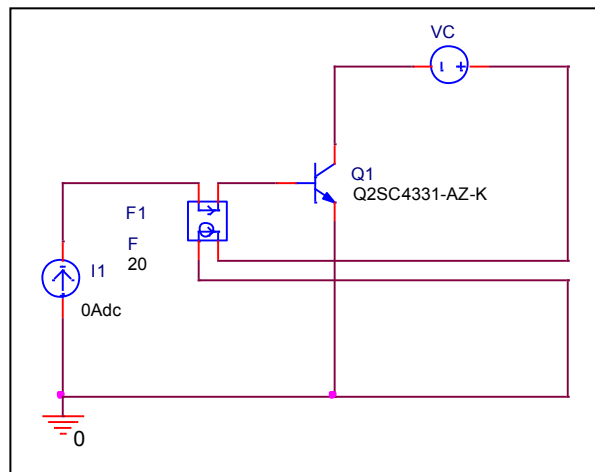

## Comparison Graph

Circuit Simulation Result

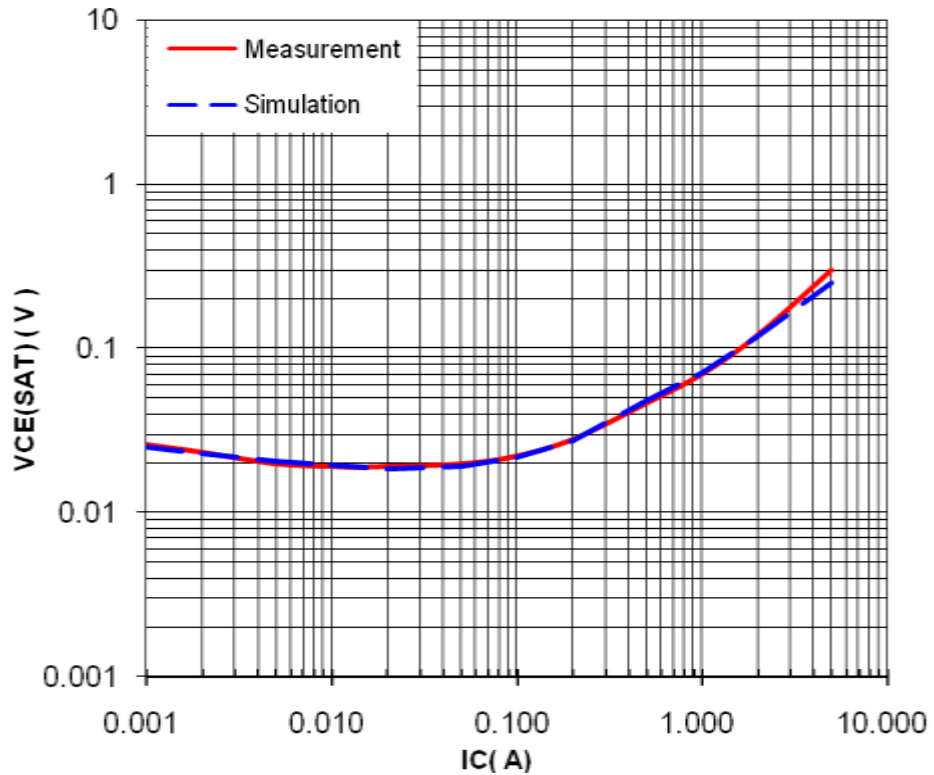

Simulation Result

IC(A)	VCE(sat)(V)		Error(%)
	Measurement	Simulation	
0.001	0.026	0.025	-3.85
0.002	0.024	0.023	-1.70
0.005	0.020	0.021	2.50
0.010	0.019	0.019	1.58
0.020	0.019	0.019	-2.63
0.050	0.020	0.019	-2.69
0.100	0.022	0.022	-1.36
0.200	0.028	0.028	-1.43
0.500	0.046	0.048	3.70
1.000	0.070	0.071	1.14
2.000	0.120	0.118	-1.67

# $V_{BE(Sat)}$ - $I_C$ Characteristics

## Circuit Simulation Result

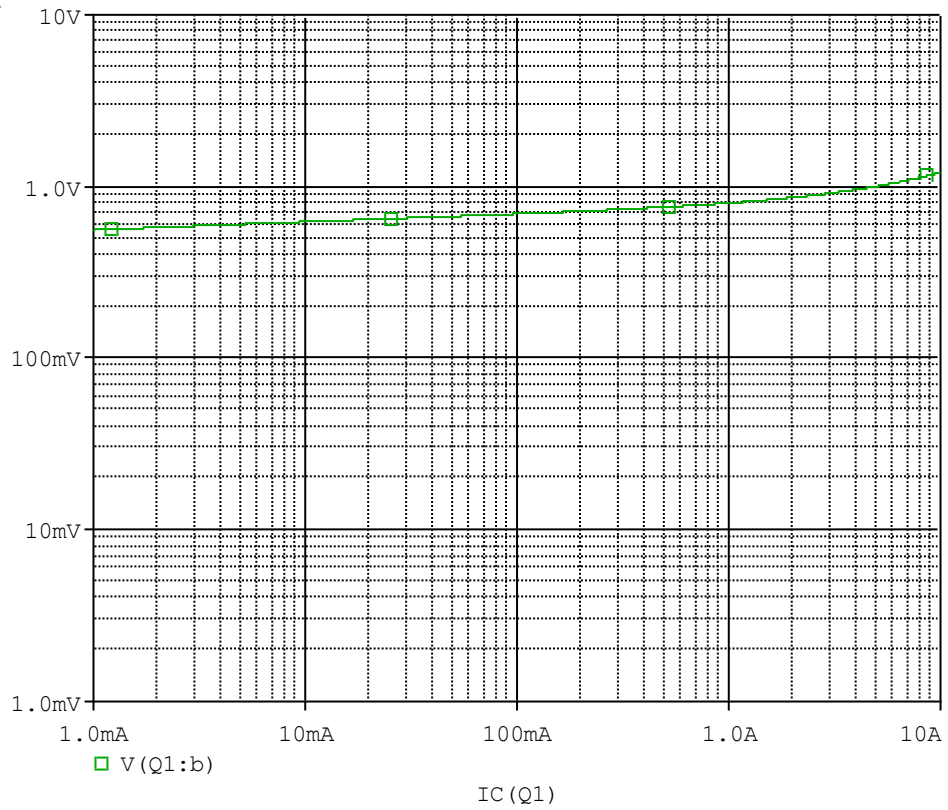

## Evaluation Circuit

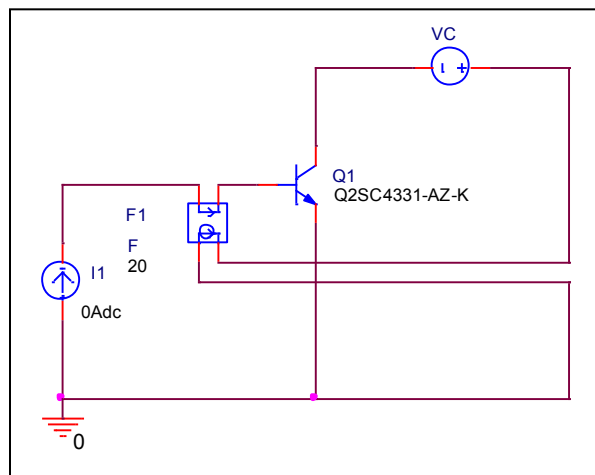

## Comparison Graph

Circuit Simulation Result

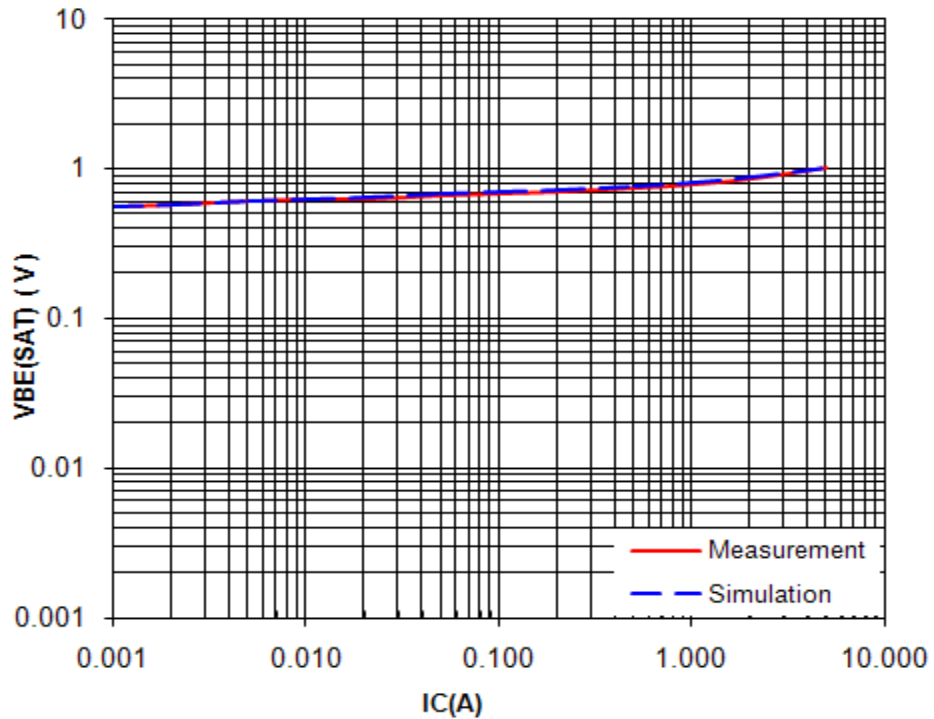

Simulation Result

IC(A)	VBE(sat)(V)		Error(%)
	Measurement	Simulation	
0.001	0.550	0.555	0.91
0.002	0.570	0.576	1.05
0.005	0.600	0.602	0.33
0.010	0.620	0.623	0.48
0.020	0.630	0.644	2.22
0.050	0.655	0.673	2.75
0.100	0.680	0.696	2.35
0.200	0.705	0.722	2.41
0.500	0.745	0.764	2.55
1.000	0.785	0.807	2.80
2.000	0.850	0.868	2.12
5.000	1.000	1.007	0.70

# Switching Characteristics

## Circuit simulation result

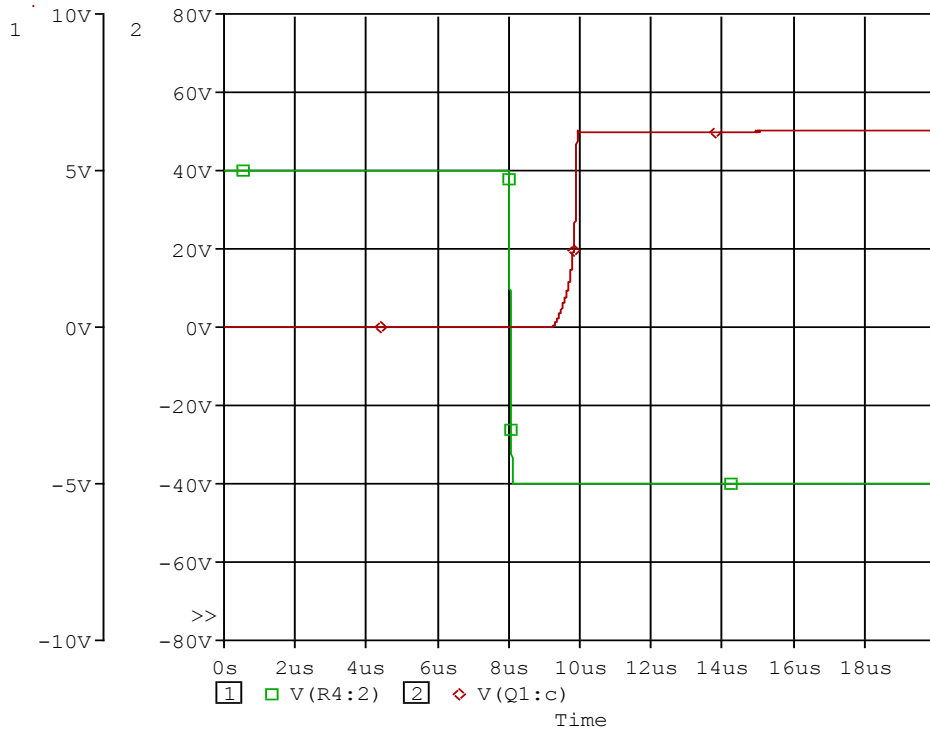

## Evaluation circuit

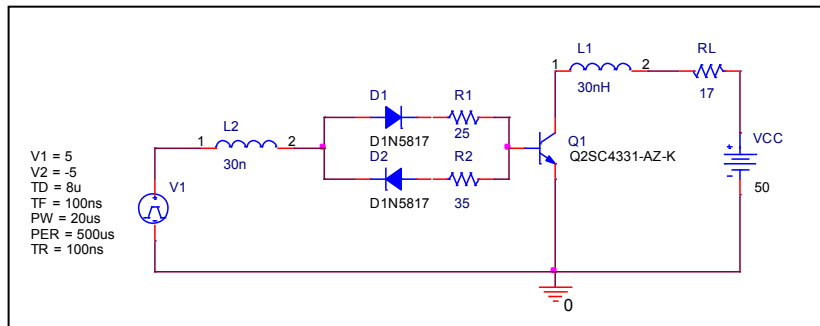

## Simulation result

	Measurement	Simulation	%Error
<b><math>t_f</math> (ns)</b>	<b>400.000</b>	<b>405.969</b>	<b>1.492</b>
<b><math>t_{stg}</math> (ns)</b>	<b>150.000</b>	<b>1504.000</b>	<b>0.267</b>

# Output Characteristics

## Circuit Simulation Result

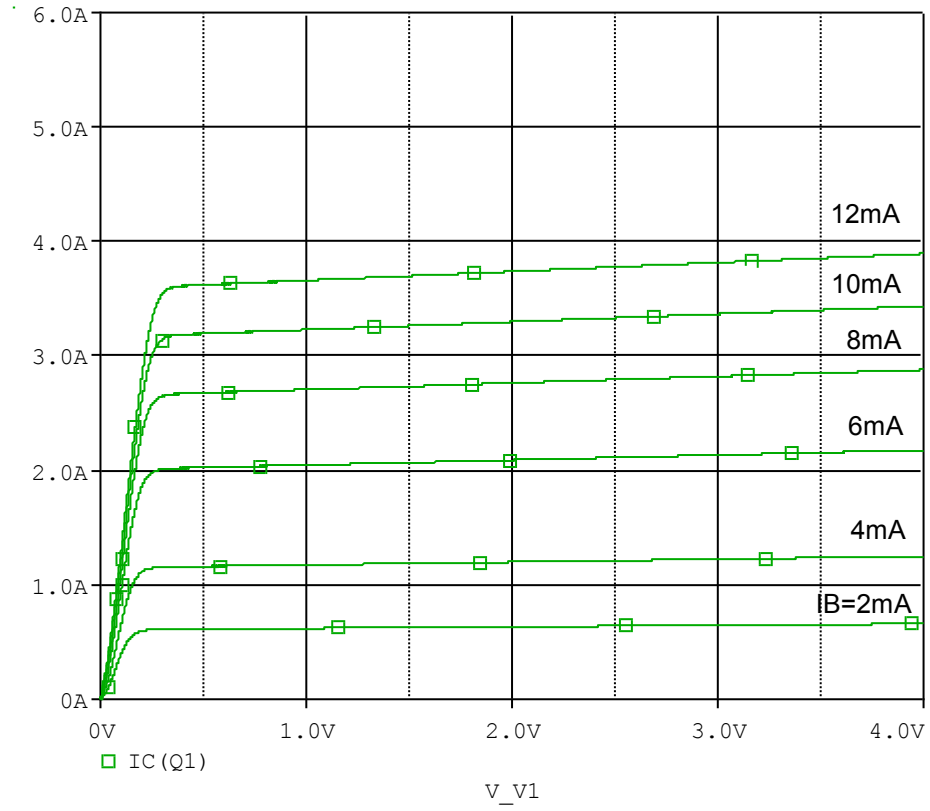

## Evaluation Circuit

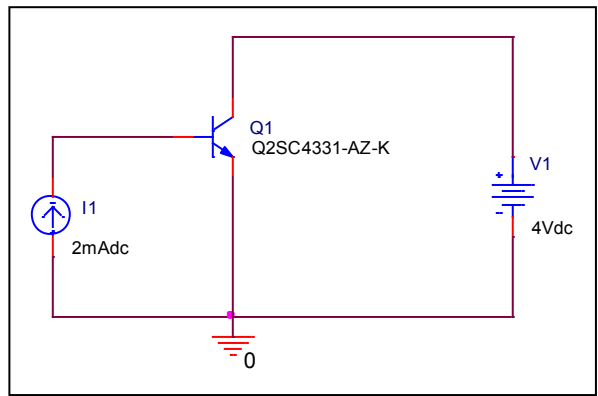

# Output Characteristics

# Reference

