

Device Modeling Report

COMPONENTS: RESISTOR
PART NUMBER: ERF10AKR33
THERMAL:TA=120(degree)
MANUFACTURER: MATSUSHITA



Bee Technologies Inc.

Equivalent circuit

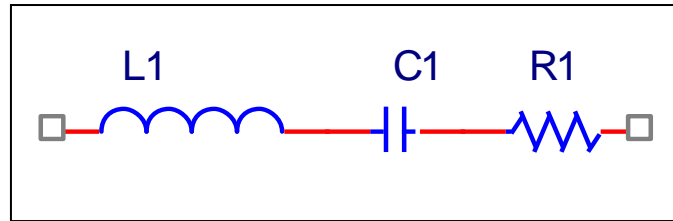

Frequency vs. |Z| Characteristic

Circuit simulation result

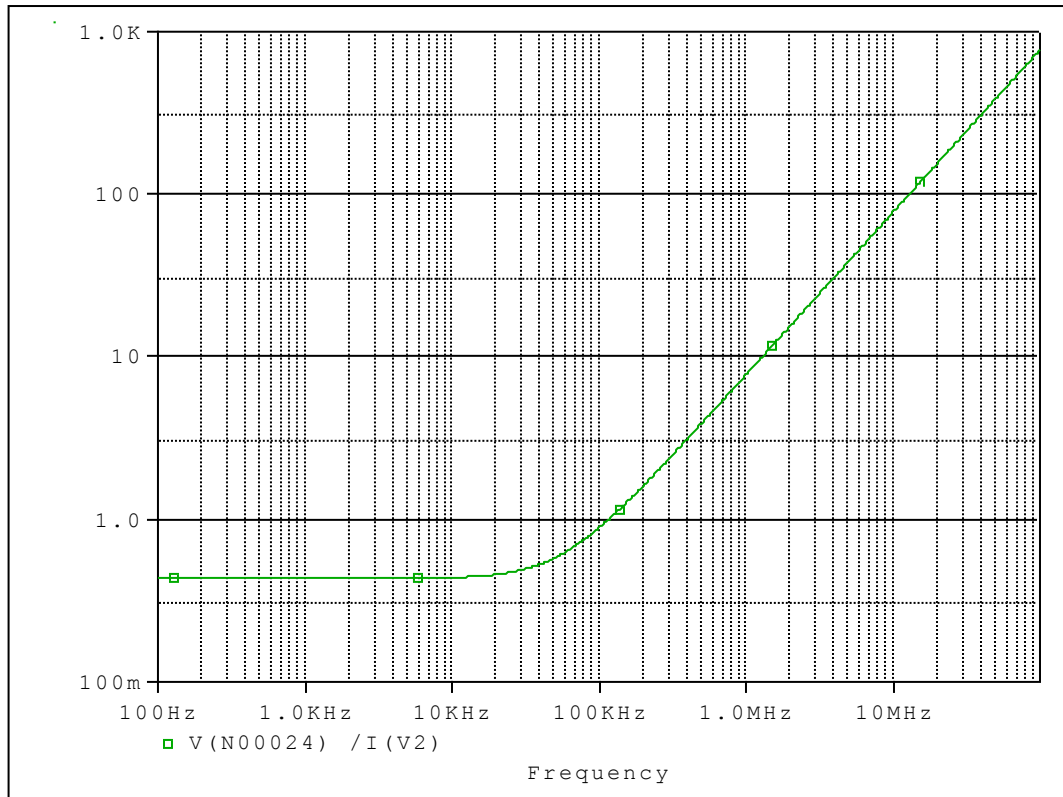

Evaluation Circuit

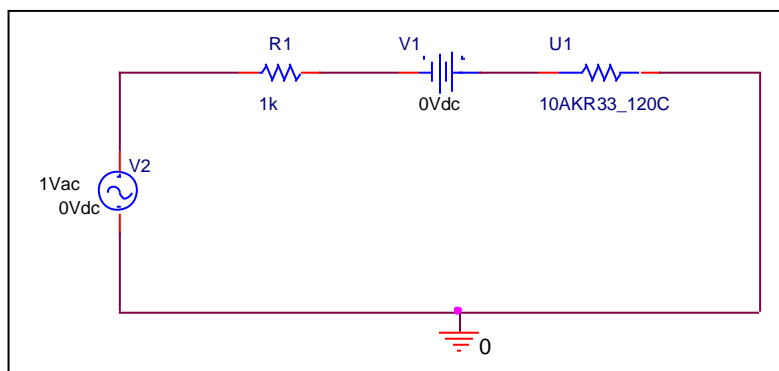

Simulation Result

Frequency(HZ)	 Z (ohm) Measurement	 Z (ohm) Circuit Simulation	%Error
100	432.910	431.386	0.352
1K	434.247	431.455	0.643
10K	441.005	438.281	0.618
100K	892.020	886.439	0.626
1M	7.933	7.755	2.248
10M	74.263	77.440	4.278