

Device Modeling Report

COMPONENTS: Light-Emitting Diode (LED) Professional
PART NUMBER: SLP-WB89A-51
MANUFACTURER: SANYO
REMARK: TA=0 degree C



Bee Technologies Inc.

PSpice model parameter	Model description
IS	Saturation Current
N	Emission Coefficient
RS	Series Resistance
IKF	High-injection Knee Current
CJO	Zero-bias Junction Capacitance
M	Junction Grading Coefficient
VJ	Junction Potential
ISR	Recombination Current Saturation Value
BV	Reverse Breakdown Voltage(a positive value)
IBV	Reverse Breakdown Current(a positive value)
TT	Transit Time
EG	Energy-band Gap

Forward Current Characteristic

Circuit Simulation Result

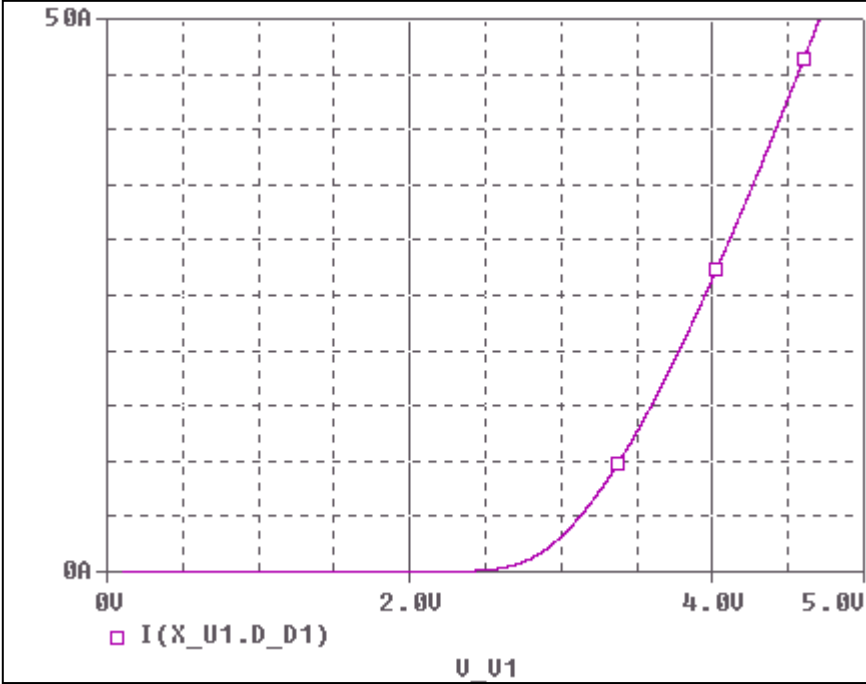

Evaluation Circuit

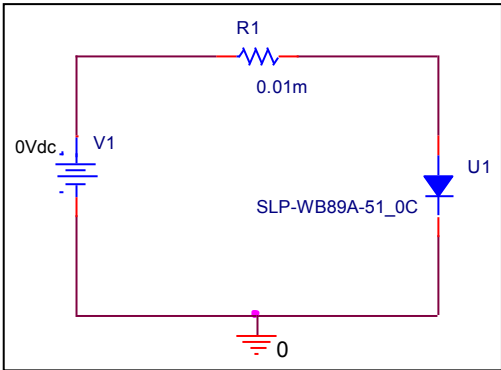

Forward Current Characteristic

Reference

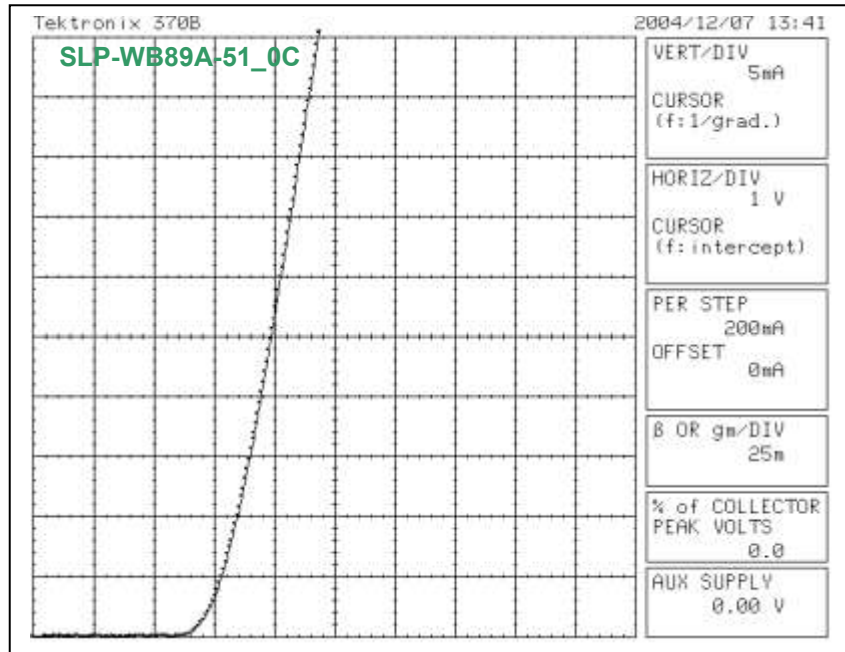

Comparison Graph

Circuit Simulation Result

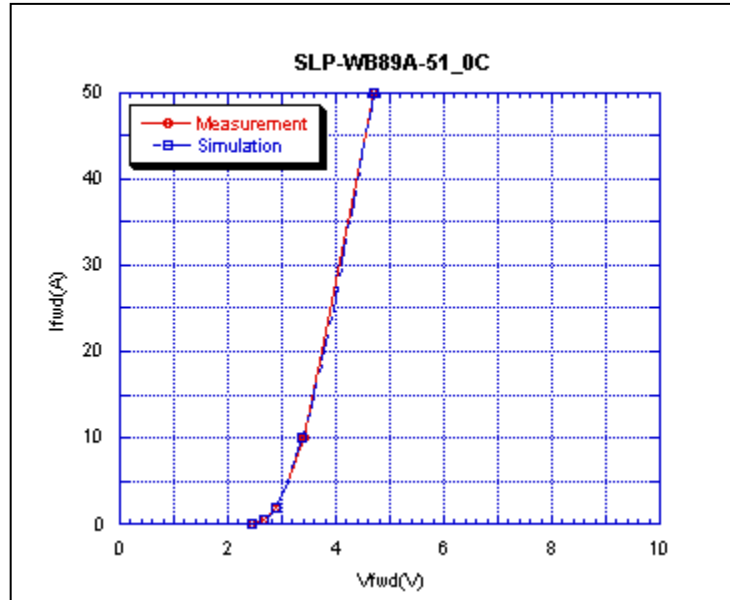

Simulation Result

Ifwd(A)	Vfwd(V) Measurement	Vfwd(V) Simulation	%Error
0.1	2.43	2.4508	0.85596
0.2	2.57	2.5408	1.13618
0.5	2.67	2.666	0.14981
1	2.75	2.7715	0.78181
2	2.9	2.8968	0.11034
5	3.13	3.1242	0.18530
10	3.4	3.3839	0.47352
20	3.76	3.7795	0.51861
50	4.71	4.705	0.10615

Capacitance Characteristic

Circuit Simulation Result

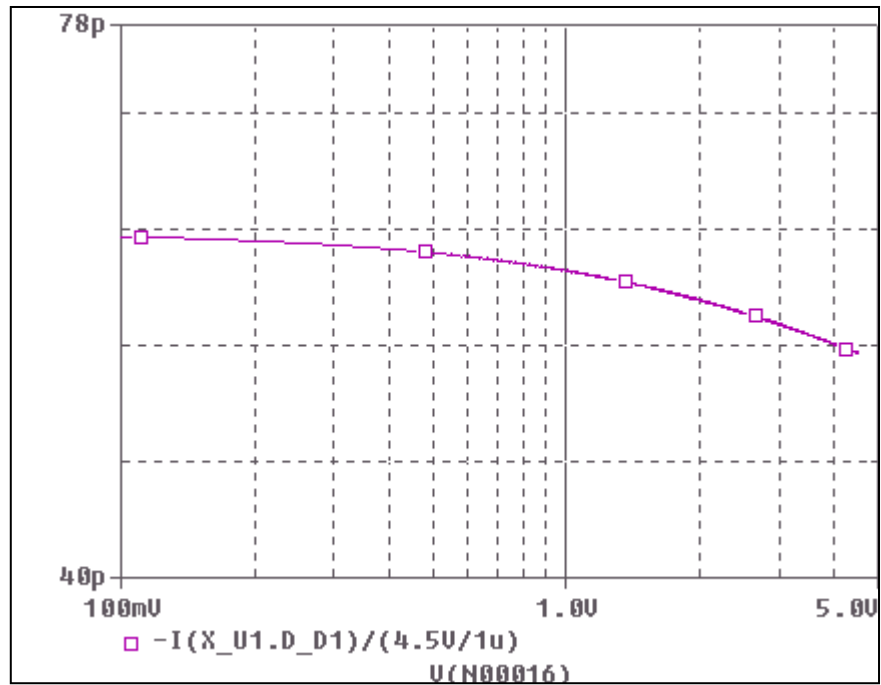

Evaluation Circuit

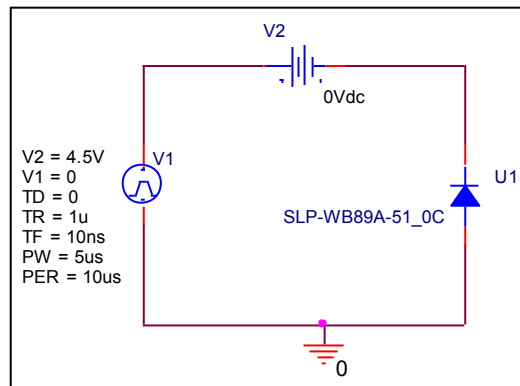

Comparison Graph

Circuit Simulation Result

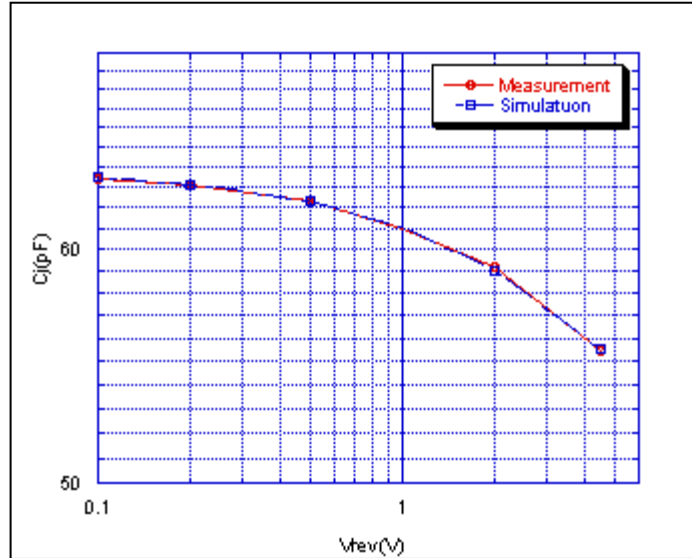

Simulation Result

Vrev(V)	Cj(pF) Measurement	Cj(pF) Simulation	%Error
0	63.8	63.8	0
0.1	63.45	63.462	0.0189
0.2	63.15	63.11	0.0633
0.5	62.3	62.364	0.1027
1	61	61.079	0.1295
2	59.2	59.045	0.2618
4.5	55.42	55.52	0.1804

Reverse Recovery Characteristic

Circuit Simulation Result

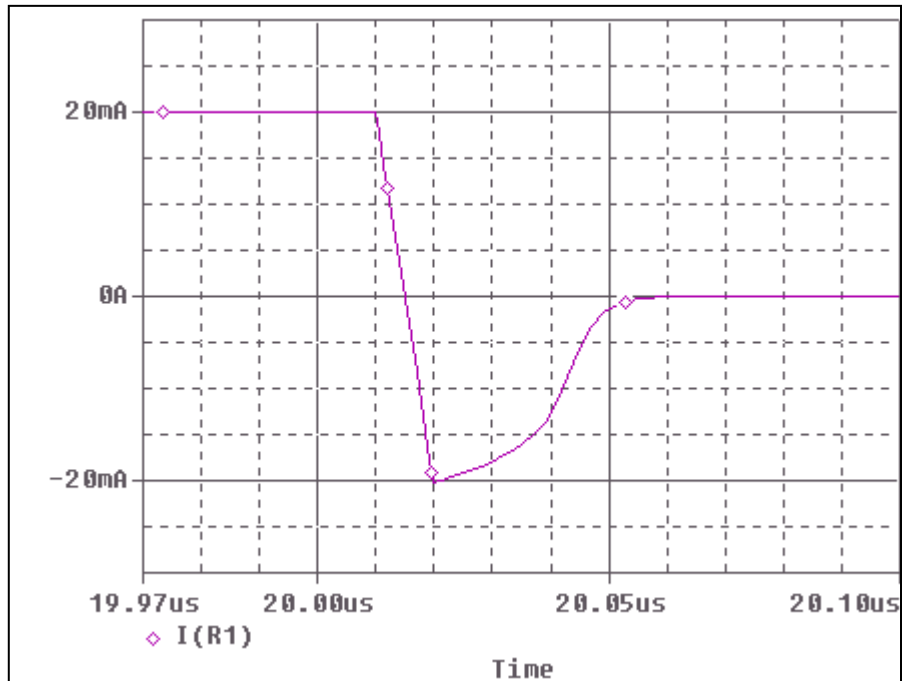

Evaluation Circuit

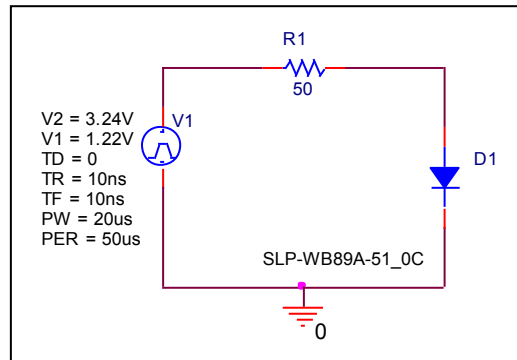

Compare Measurement vs. Simulation

Symbol	Measurement	Unit	Simulation	Unit	%Error
trj	7.2	ns	7.19	ns	- 0.1388
trb	26.4	ns	26.18	ns	- 0.8333

Reverse Recovery Characteristic

Reference

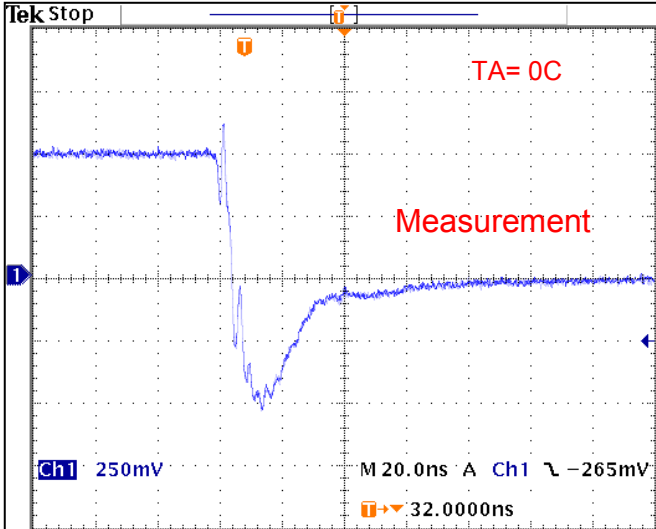

Trj =7.2(ns)
Trb=26.4(ns)
Conditions: Ifwd=Irev=0.02(A), RI=50

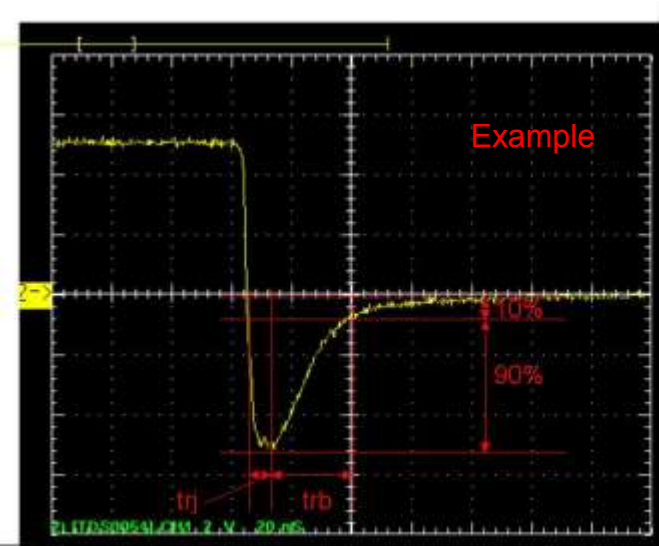

Relation between trj and trb