

Device Modeling Report

COMPONENTS: MOSFET (Professional Model)
PART NUMBER: 2SK2414
MANUFACTURER: NEC Corporation
REMARK: Body Diode (Professional Model) /
ESD Protection Diode



Bee Technologies Inc.

MOSFET MODEL PARAMETERS

PSpice model parameter	Model description
LEVEL	
L	Channel Length
W	Channel Width
KP	Transconductance
RS	Source Ohmic Resistance
RD	Ohmic Drain Resistance
VTO	Zero-bias Threshold Voltage
RDS	Drain-Source Shunt Resistance
TOX	Gate Oxide Thickness
CGSO	Zero-bias Gate-Source Capacitance
CGDO	Zero-bias Gate-Drain Capacitance
CBD	Zero-bias Bulk-Drain Junction Capacitance
MJ	Bulk Junction Grading Coefficient
PB	Bulk Junction Potential
FC	Bulk Junction Forward-bias Capacitance Coefficient
RG	Gate Ohmic Resistance
IS	Bulk Junction Saturation Current
N	Bulk Junction Emission Coefficient
RB	Bulk Series Resistance
PHI	Surface Inversion Potential
GAMMA	Body-effect Parameter
DELTA	Width effect on Threshold Voltage
ETA	Static Feedback on Threshold Voltage
THETA	Mobility Modulation
KAPPA	Saturation Field Factor
VMAX	Maximum Drift Velocity of Carriers
XJ	Metallurgical Junction Depth
UO	Surface Mobility

Transconductance Characteristics

Circuit Simulation Result

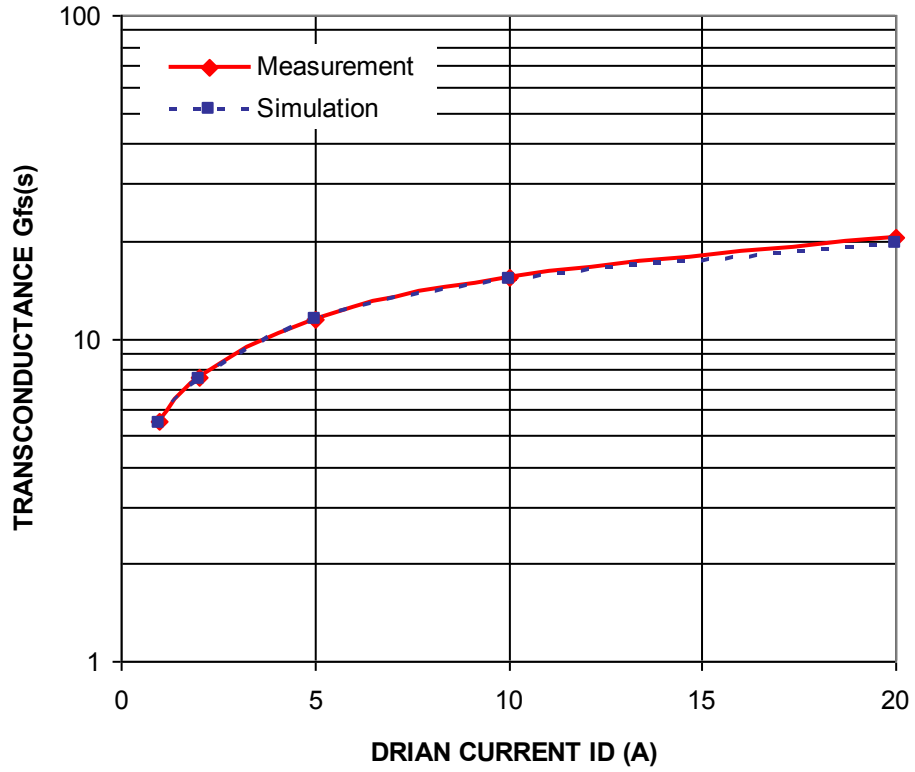

Comparison table

Id(A)	gfs(s)		Error(%)
	Measurement	Simulation	
1	5.535	5.435	-1.807
2	7.591	7.491	-1.317
5	11.390	11.499	0.961
10	15.385	15.212	-1.120
20	20.665	19.802	-4.176

Vgs-Id Characteristics

Circuit Simulation Result

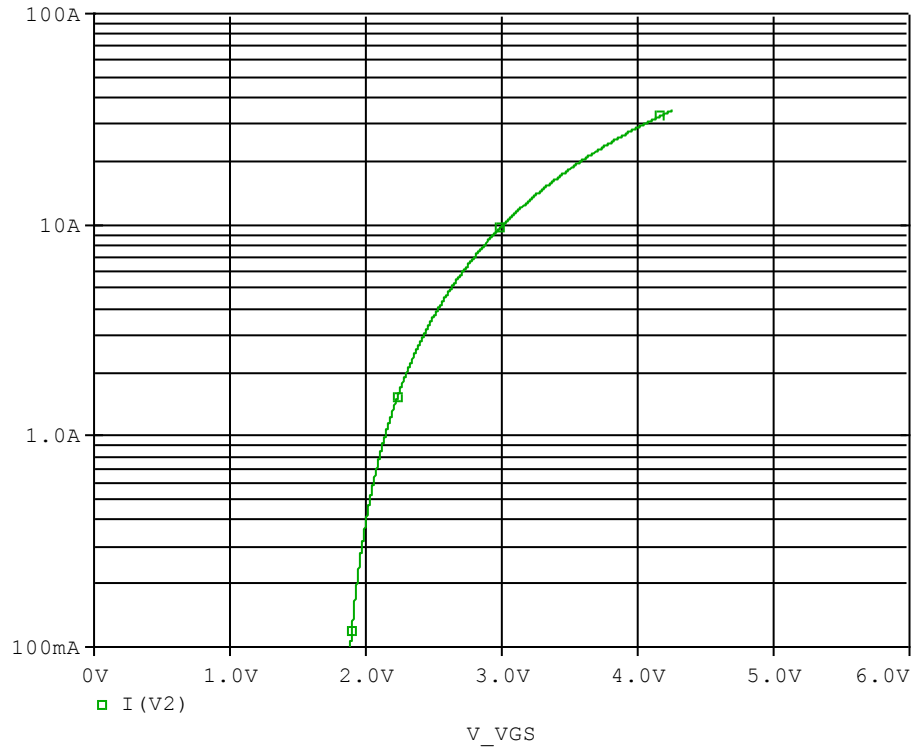

Evaluation circuit

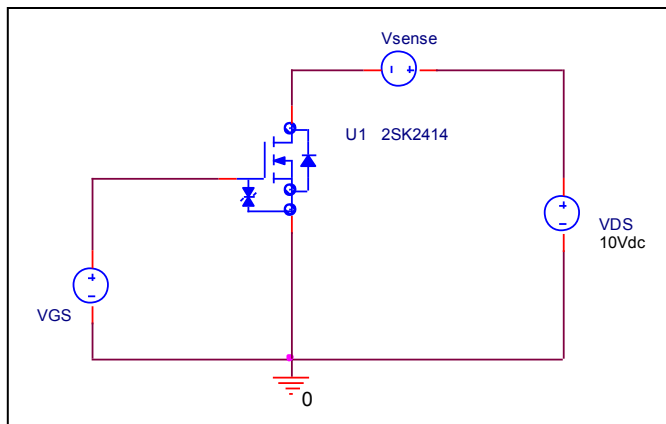

Comparison Graph

Circuit Simulation Result

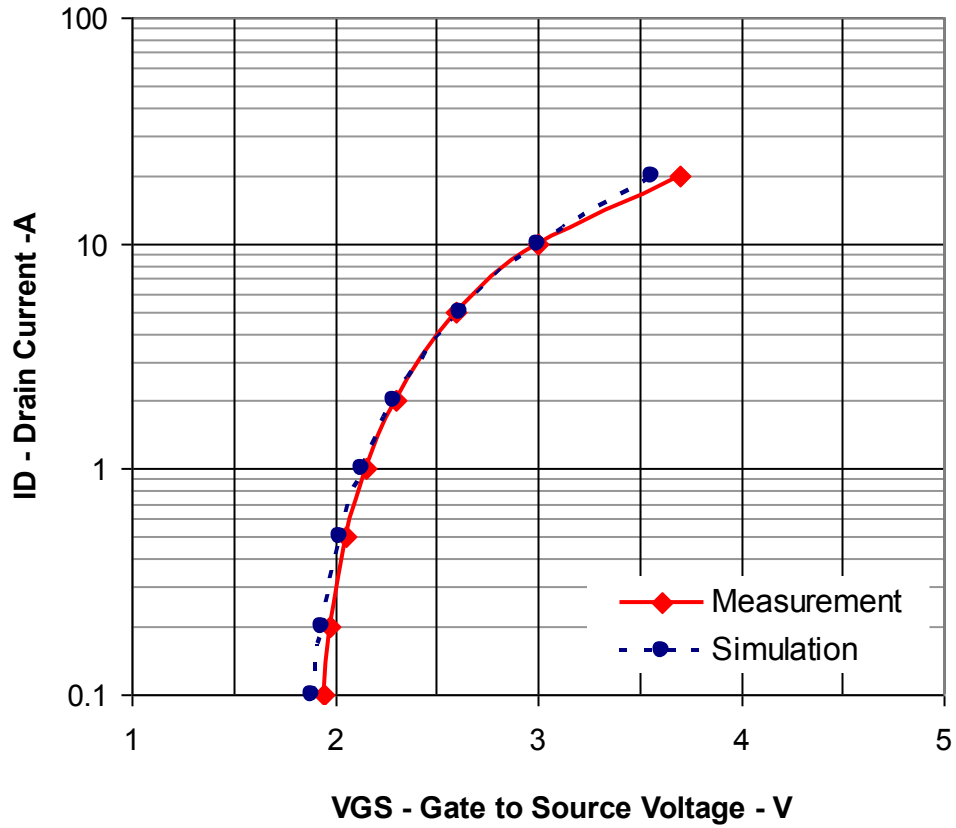

Comparison table

I_D (A)	V_{GS} (V)		Error (%)
	Measurement	Simulation	
0.1	1.950	1.884	-3.369
0.2	1.980	1.932	-2.424
0.5	2.050	2.028	-1.088
1	2.150	2.137	-0.595
2	2.300	2.295	-0.222
5	2.600	2.618	0.696
10	3.000	2.999	-0.050
20	3.700	3.563	-3.716

*Rds(on) Characteristic

Circuit Simulation result

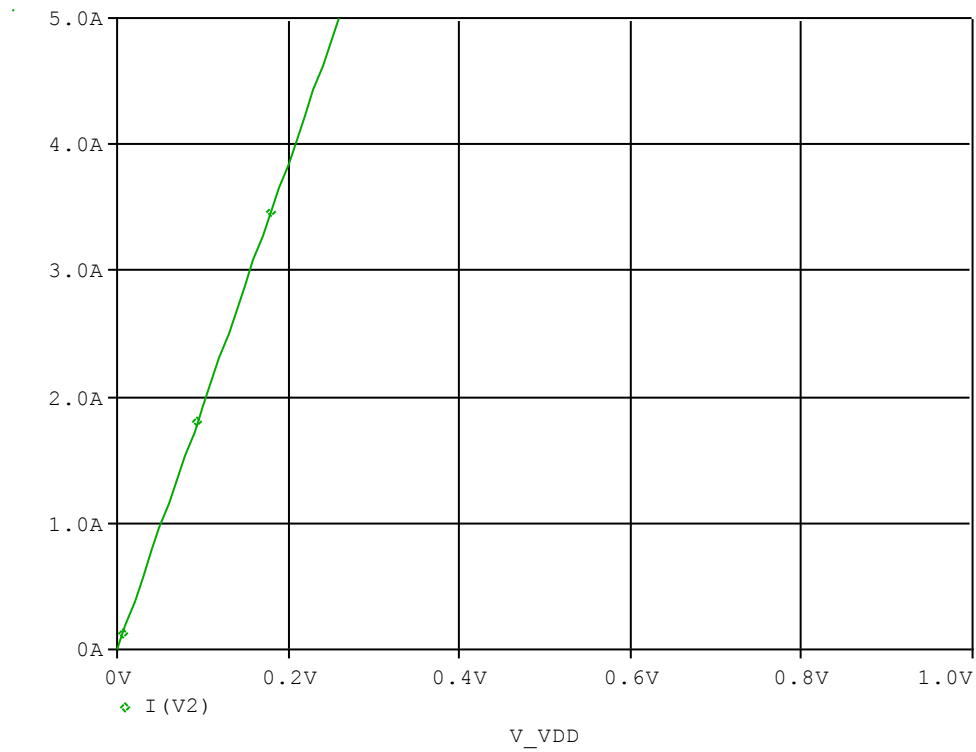

Evaluation circuit

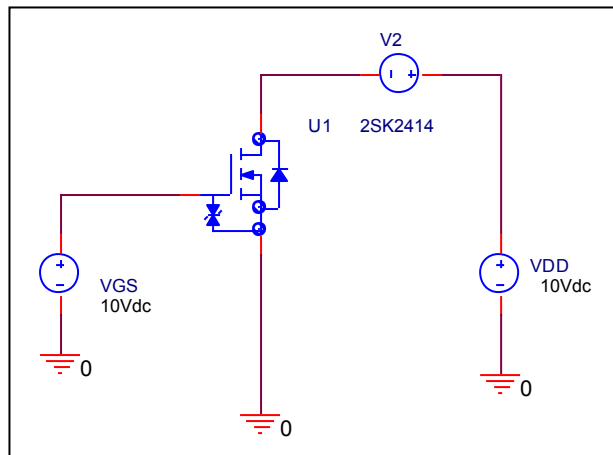

Simulation Result

$I_D=5.0A, V_{GS}=10V$	Measurement		Simulation		Error (%)
$R_{DS} (on)$	52.00	mΩ	52.00	mΩ	0.00

Gate Charge Characteristic

Circuit Simulation result

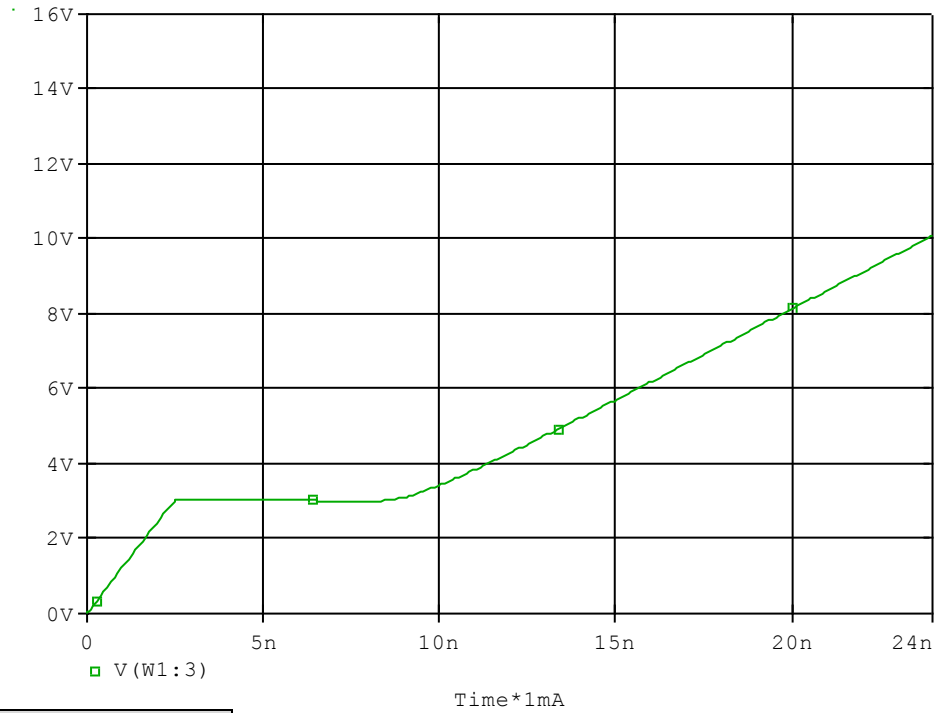

Evaluation circuit

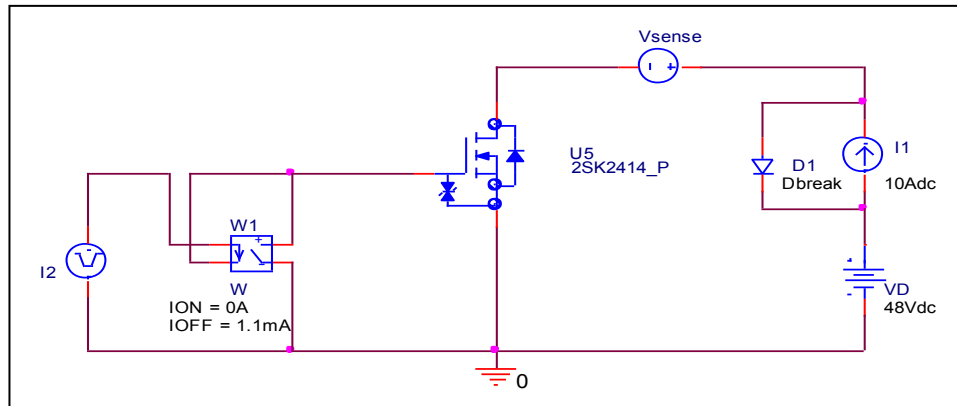

Simulation Result

$V_{DD}=48V, I_D=10A,$ $V_{GS}=10V$		Measurement	Simulation	Error (%)
QGS	nC	2.600	2.605	0.192
QGD	nC	6.000	6.073	1.217
QG	nC	24.000	24.000	0.000

Capacitance Characteristic

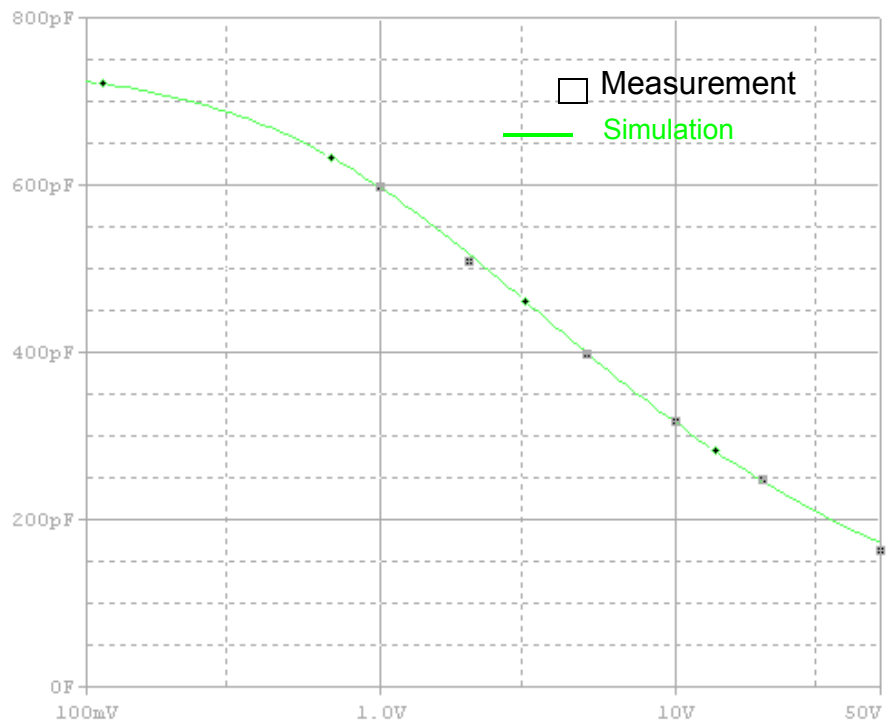

Simulation Result

V _{DS} (V)	Cbd (pF)		Error(%)
	Measurement	Simulation	
1	600.00	600.00	0.00
2	510.00	508.00	-0.39
5	400.00	388.00	-3.00
10	320.00	309.00	-3.44
20	250.00	248.00	-0.80
50	165.00	160.00	-3.03

Switching Time Characteristic

Circuit Simulation result

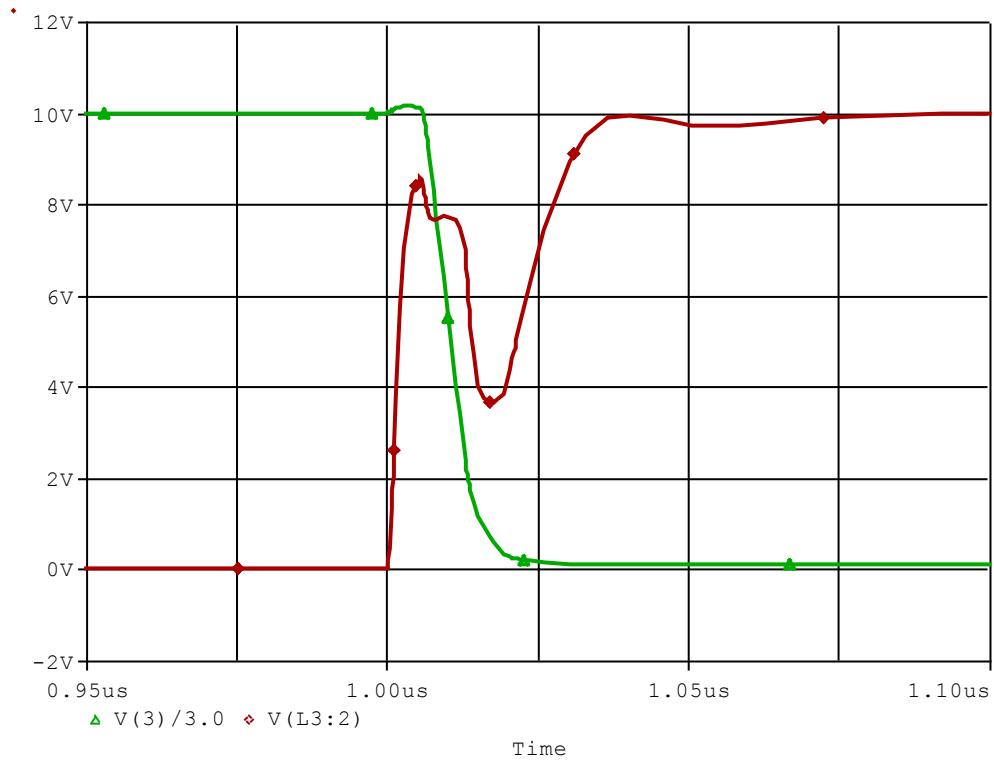

Evaluation circuit

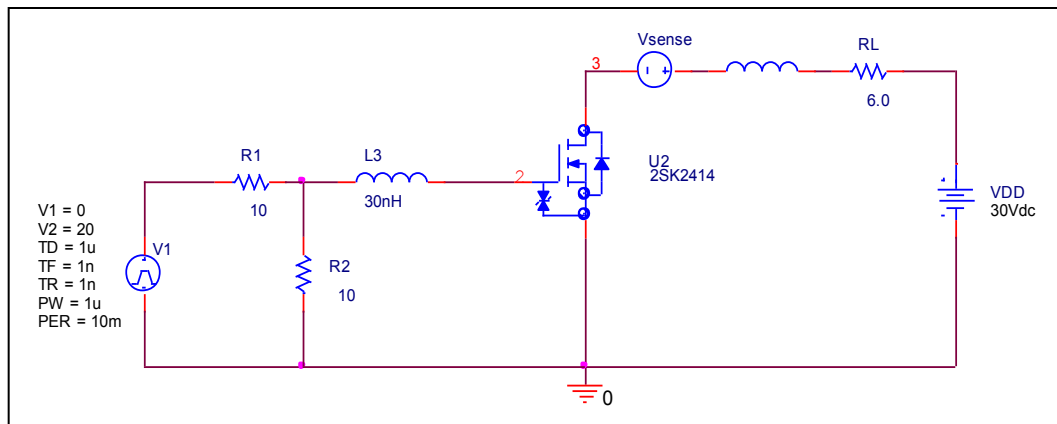

Simulation Result

$I_D=5.0A, V_{DD}=30V$ $V_{GS}=0/10V$		Measurement	Simulation	Error(%)
td(on)	ns	15.00	15.01	0.067

Output Characteristic

Circuit Simulation result

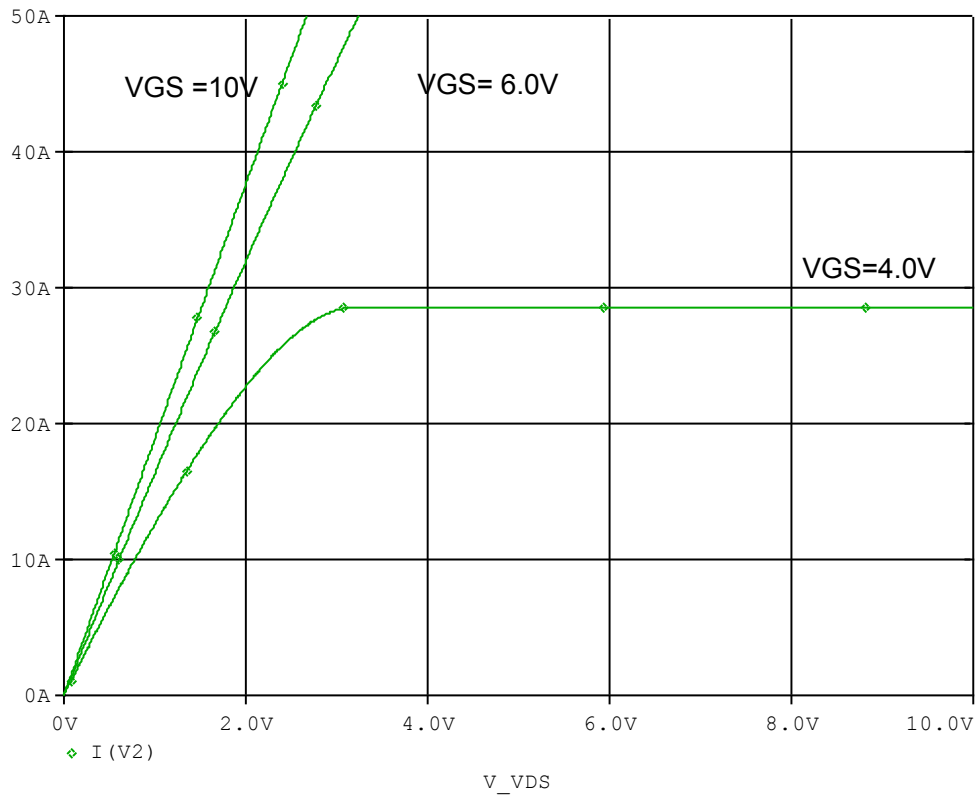

Evaluation circuit

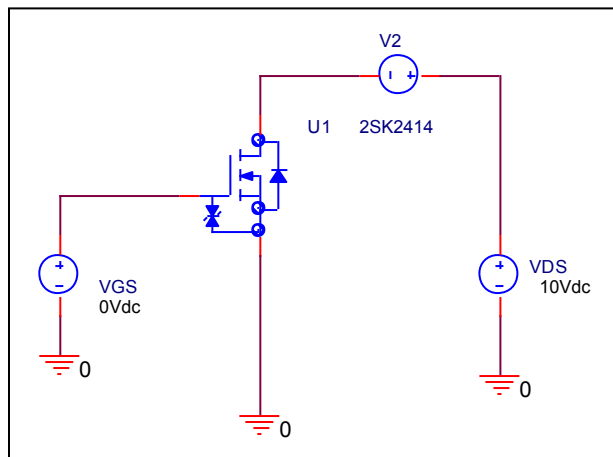

BODY DIODE SPICE MODEL Forward Current Characteristic

Circuit Simulation Result

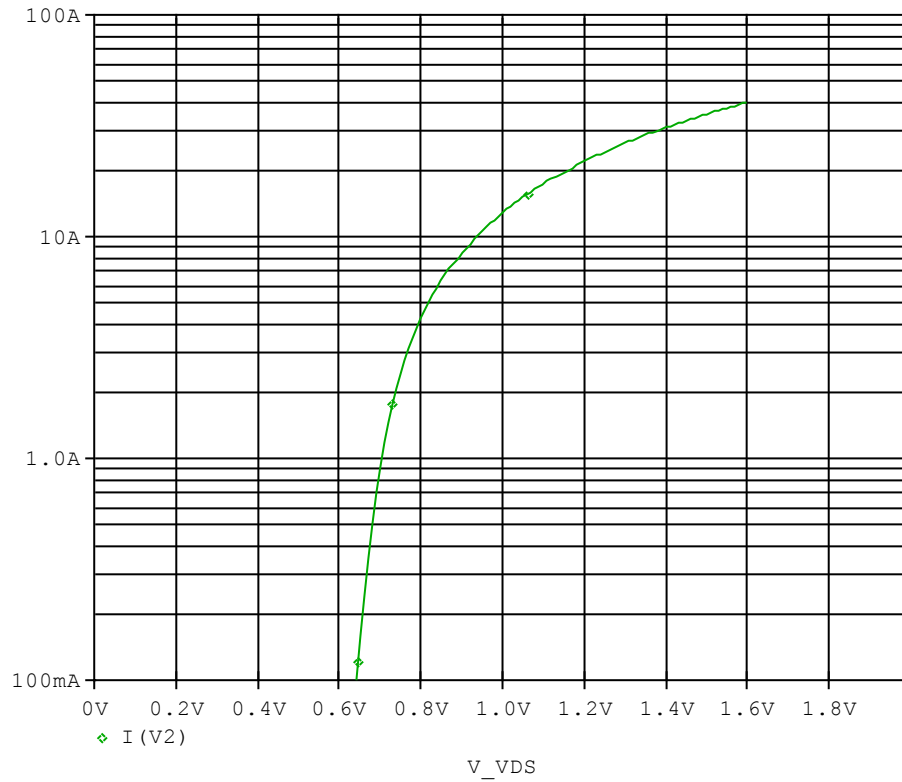

Evaluation Circuit

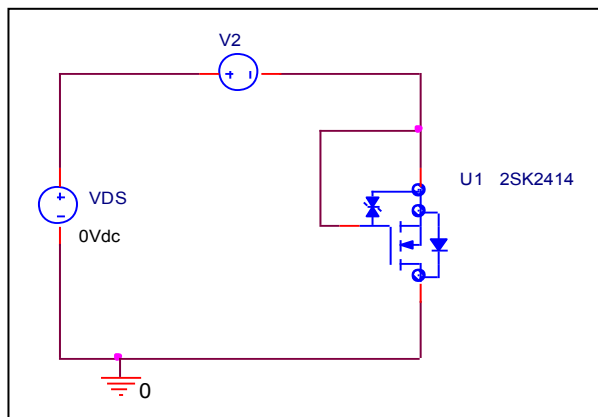

Comparison Graph

Circuit Simulation Result

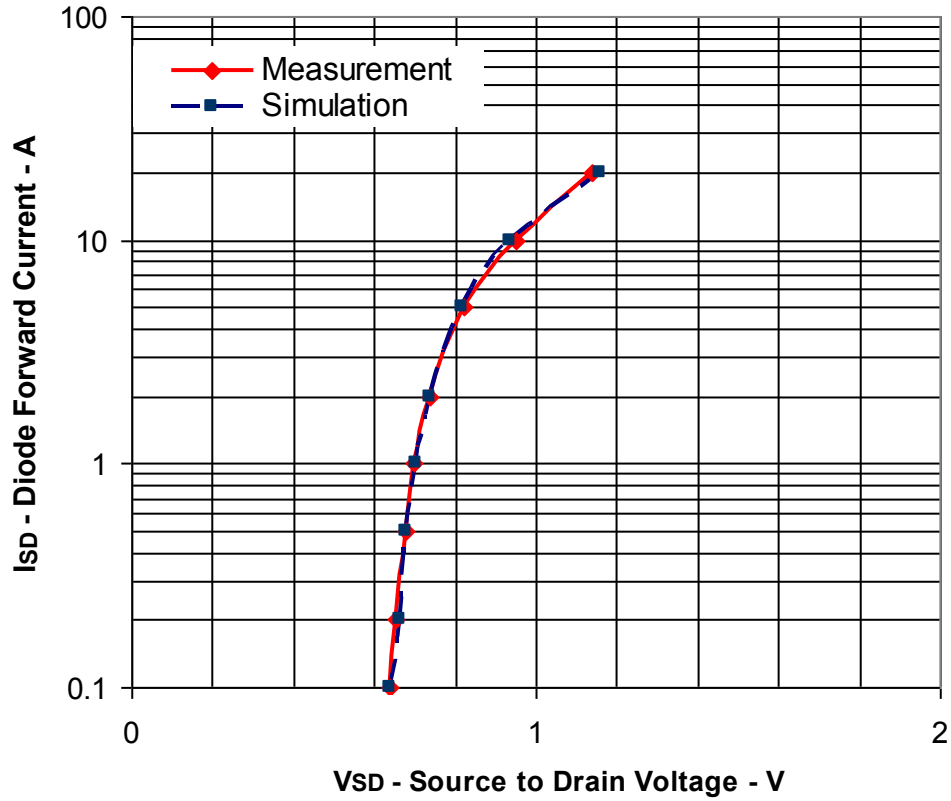

Simulation Result

ISD(A)	VDS(V)		%Error
	Measurement	Simulation	
0.1	0.6400	0.6401	0.0156
0.2	0.6550	0.6652	1.5573
0.5	0.6800	0.6794	-0.0882
1	0.7000	0.7032	0.4571
2	0.7400	0.7376	-0.3243
5	0.8200	0.8182	-0.2195
10	0.9500	0.9365	-1.4211
20	1.1400	1.1601	1.7632

Reverse Recovery Characteristic

Circuit Simulation Result

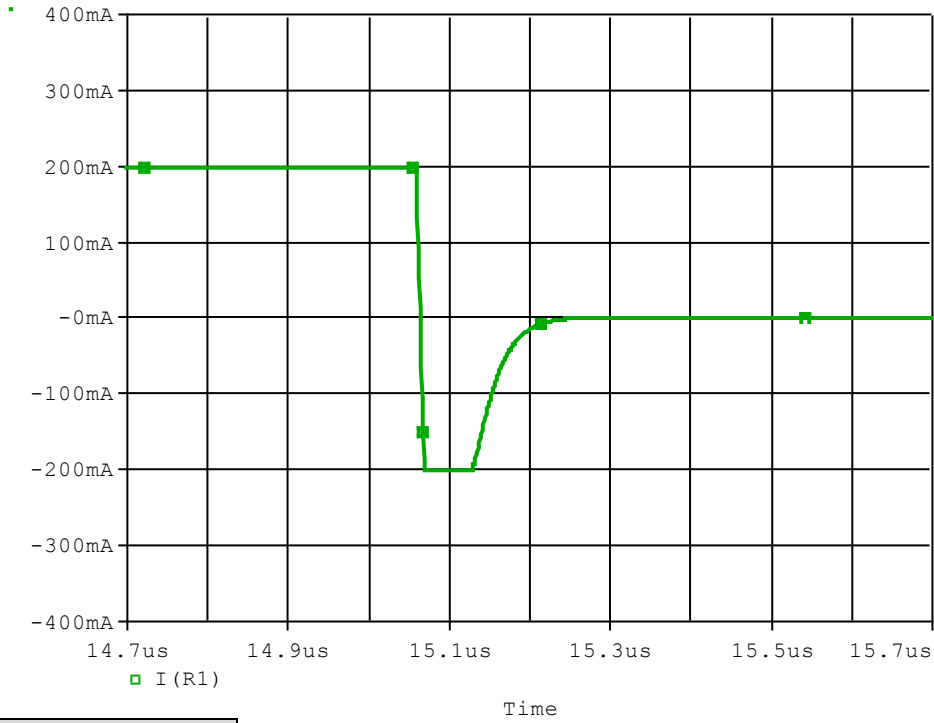

Evaluation Circuit

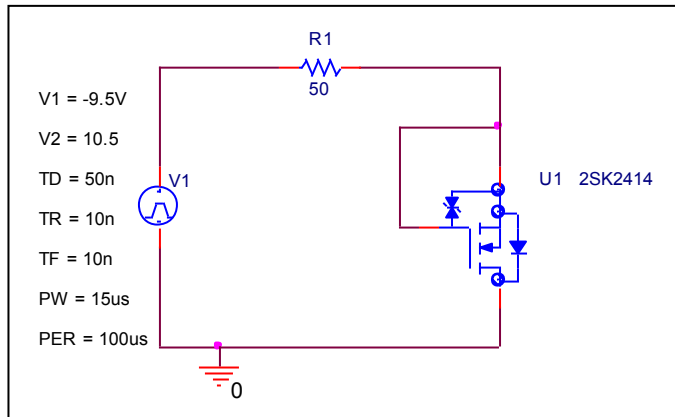

Compare Measurement vs. Simulation

	Measurement	Simulation	Error (%)
trr (ns)	130.00	130.10	0.077

Reverse Recovery Characteristic

Reference

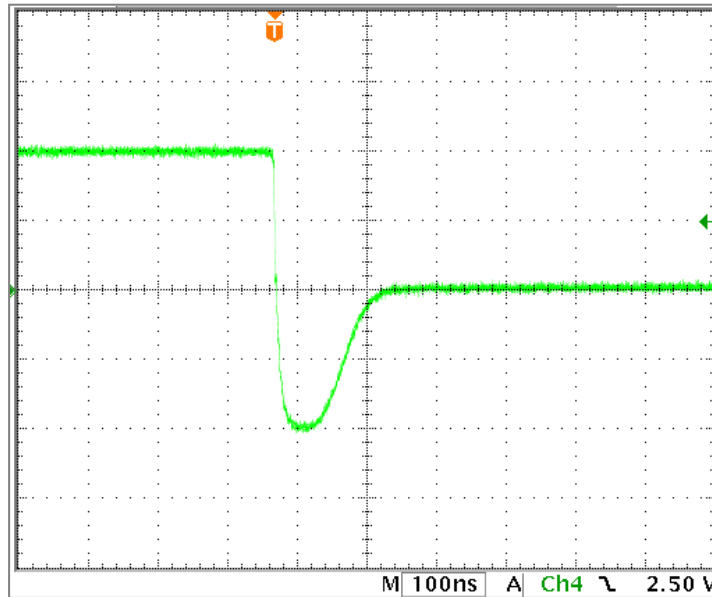

Trj=60.0(ns)
Trb=70.0(ns)
Conditions: Ifwd=Irev=0.2(A), RI=50

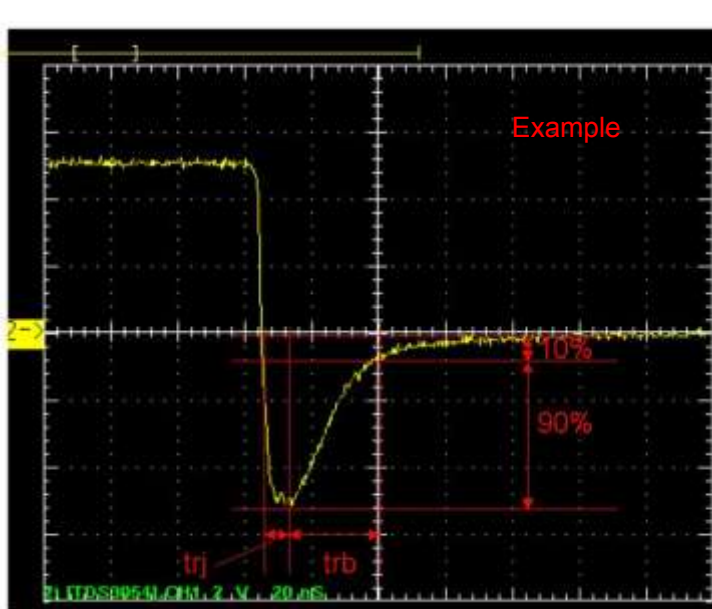

Relation between trj and trb

ESD PROTECTION DIODE SPICE MODEL

Zener Voltage Characteristic

Circuit Simulation Result

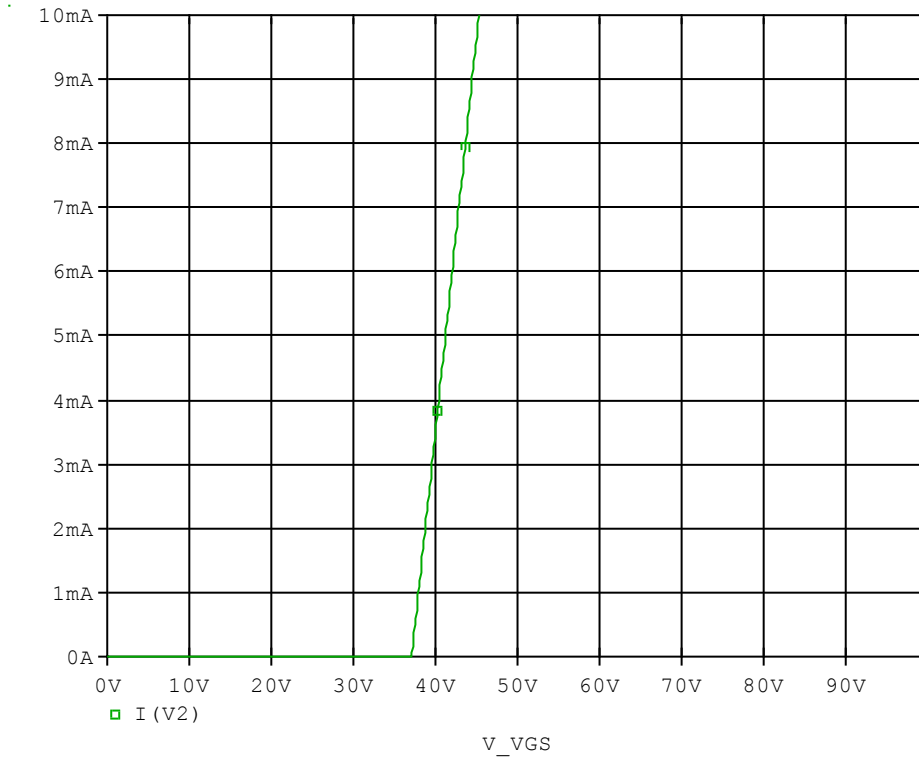

Evaluation Circuit

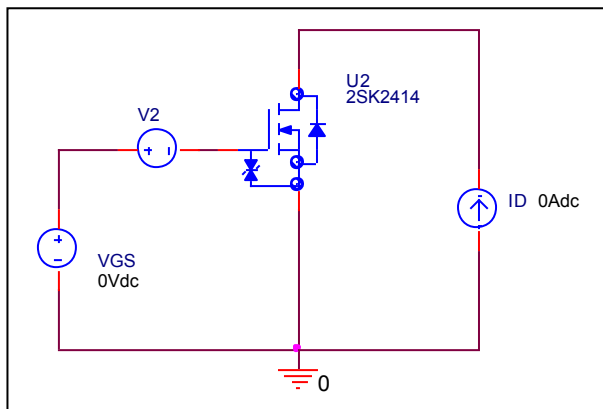

Zener Voltage Characteristic

Reference

