

Device Modeling Report

COMPONENTS: MOSFET (Model Parameters)
PART NUMBER: 2SK1828
MANUFACTURER: TOSHIBA
Body Diode (Standard) / Source-Gate Diode (DSG)



Bee Technologies Inc.

MOSFET MODEL PARAMETERS

PSpice model parameter	Model description
LEVEL	
L	Channel Length
W	Channel Width
KP	Transconductance
RS	Source Ohmic Resistance
RD	Ohmic Drain Resistance
VTO	Zero-bias Threshold Voltage
RDS	Drain-Source Shunt Resistance
TOX	Gate Oxide Thickness
CGSO	Zero-bias Gate-Source Capacitance
CGDO	Zero-bias Gate-Drain Capacitance
CBD	Zero-bias Bulk-Drain Junction Capacitance
MJ	Bulk Junction Grading Coefficient
PB	Bulk Junction Potential
FC	Bulk Junction Forward-bias Capacitance Coefficient
RG	Gate Ohmic Resistance
IS	Bulk Junction Saturation Current
N	Bulk Junction Emission Coefficient
RB	Bulk Series Resistance
PHI	Surface Inversion Potential
GAMMA	Body-effect Parameter
DELTA	Width effect on Threshold Voltage
ETA	Static Feedback on Threshold Voltage
THETA	Mobility Modulation
KAPPA	Saturation Field Factor
VMAX	Maximum Drift Velocity of Carriers
XJ	Metallurgical Junction Depth
UO	Surface Mobility

Transconductance Characteristic

Circuit Simulation Result

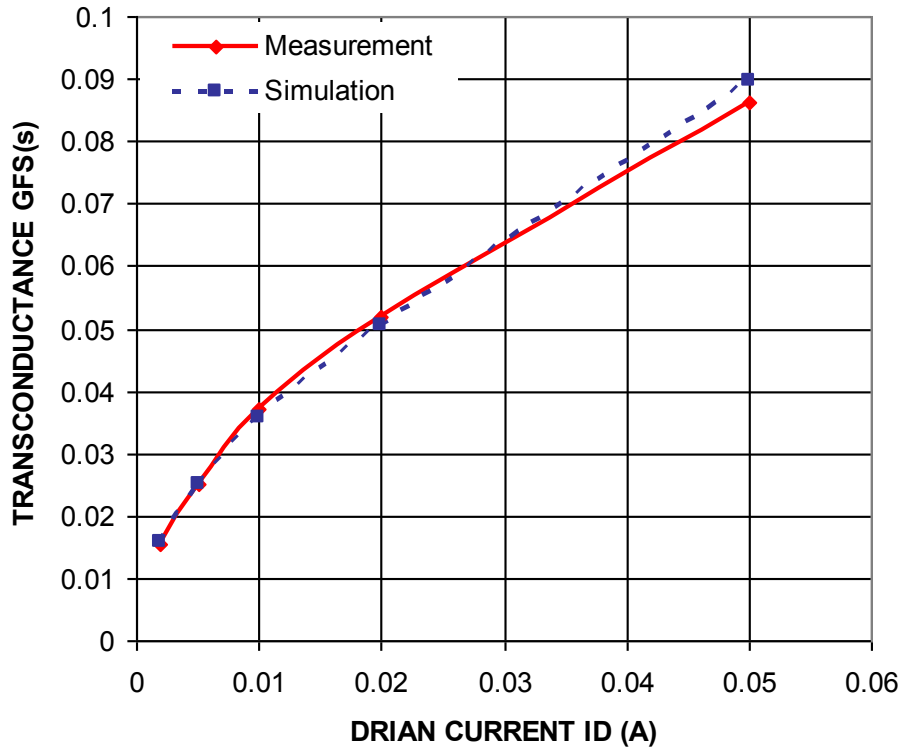

Comparison table

Id(A)	Gfs(S)		Error(%)
	Measurement	Simulation	
0.002	0.0154	0.0159	3.17
0.005	0.0250	0.0253	1.01
0.01	0.0370	0.0357	-3.57
0.02	0.0519	0.0505	-2.78
0.05	0.0862	0.0898	4.13

Vgs-Id Characteristic

Circuit Simulation result

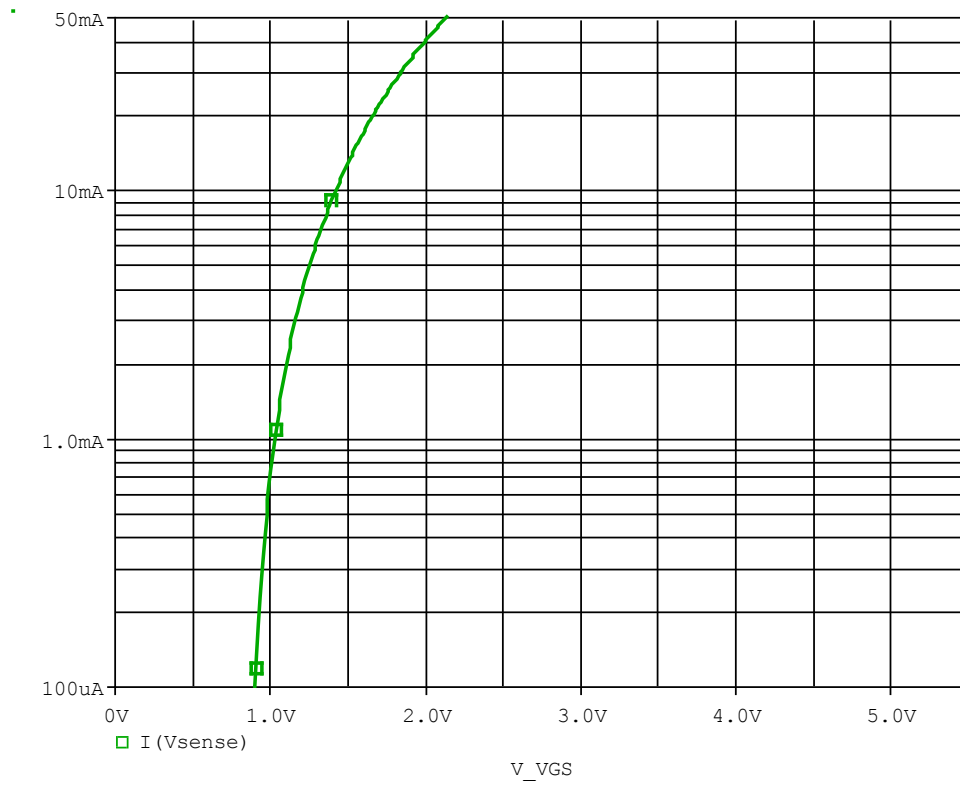

Evaluation circuit

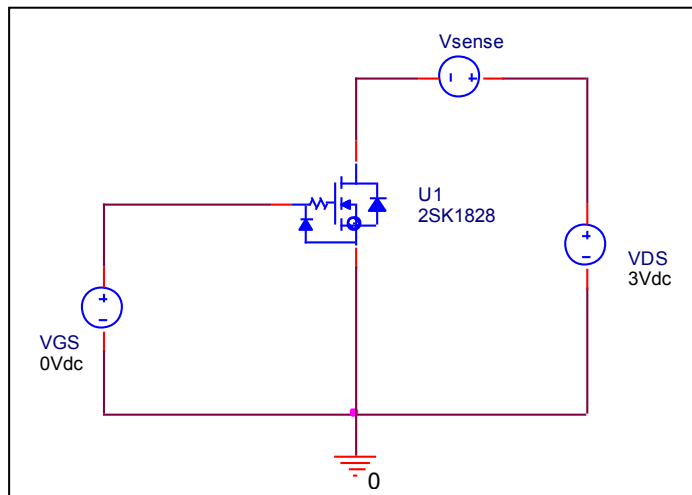

Comparison Graph

Circuit Simulation Result

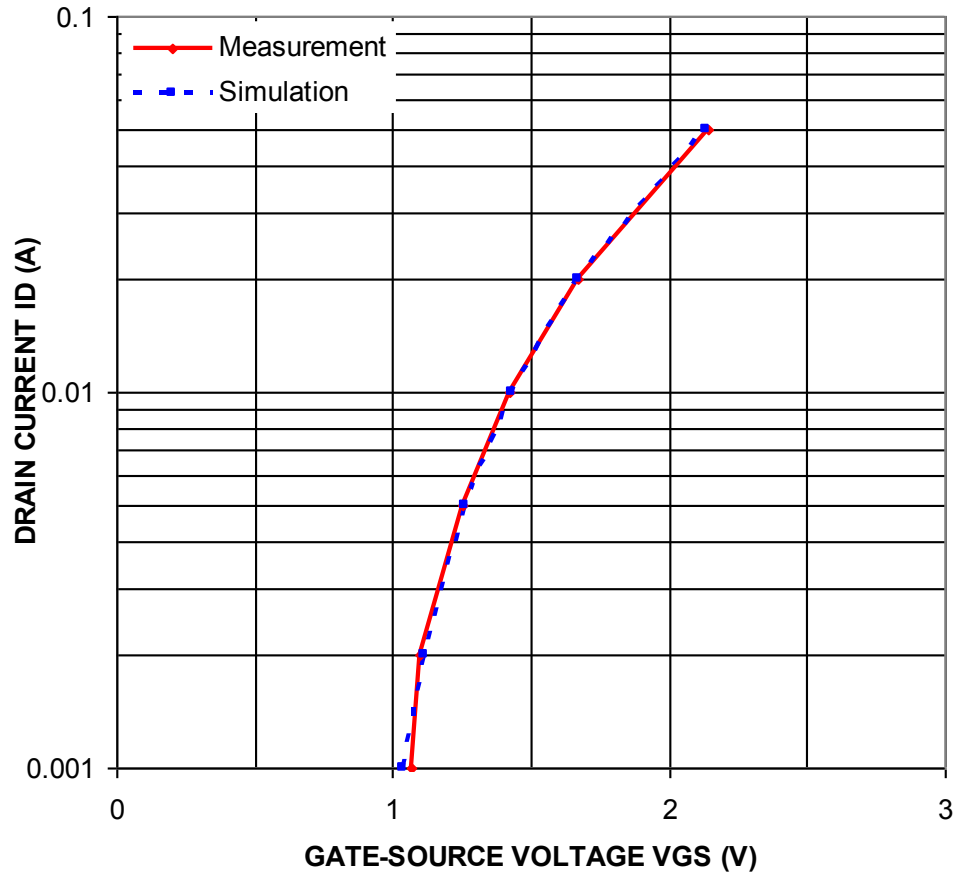

Simulation Result

I _D (A)	V _{GS} (V)		Error (%)
	Measurement	Simulation	
0.001	1.07	1.0348	-3.29
0.002	1.1	1.1101	0.92
0.005	1.25	1.2621	0.97
0.01	1.42	1.432	0.85
0.02	1.67	1.67	0.00
0.05	2.14	2.1359	-0.19

Rds(on) Characteristic

Circuit Simulation result

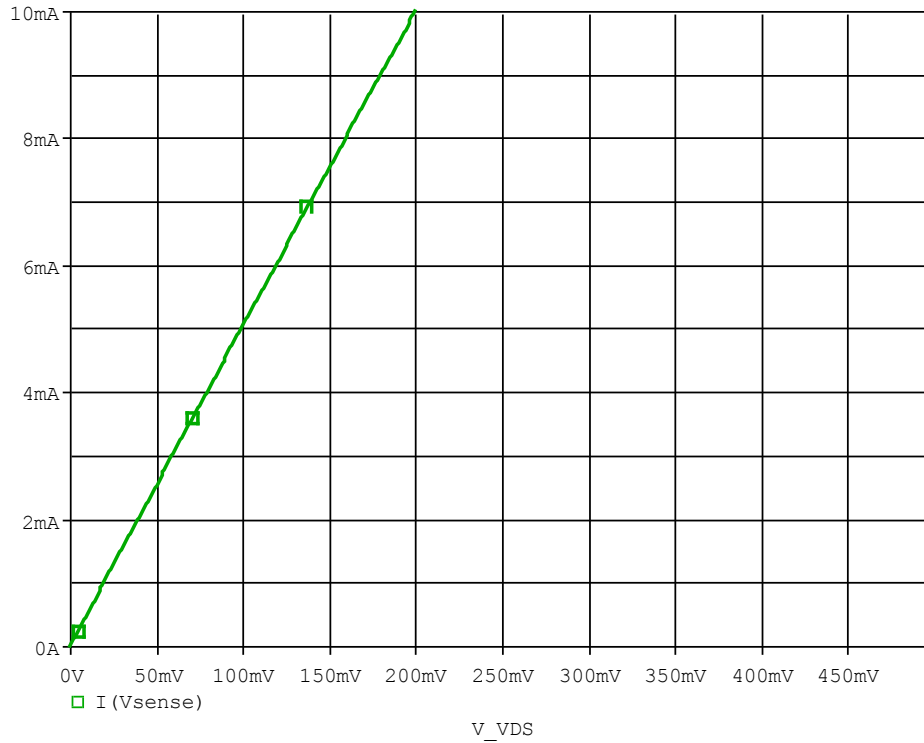

Evaluation circuit

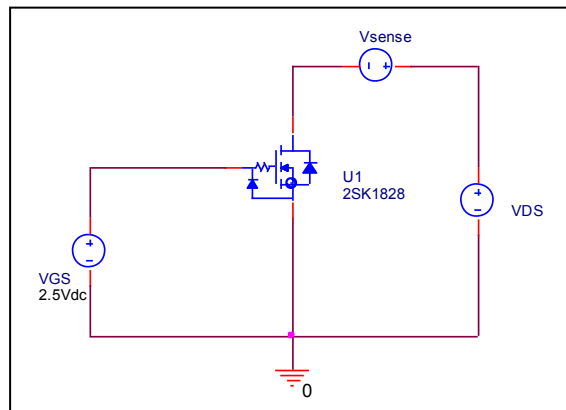

Simulation Result

$I_D=10\text{mA}$, $V_{GS}=2.5\text{V}$	Measurement		Simulation		Error (%)
$R_{DS} \text{ (on)}$	20.000	Ω	19.9982	Ω	- 0.09

Gate Charge Characteristic

Circuit Simulation result

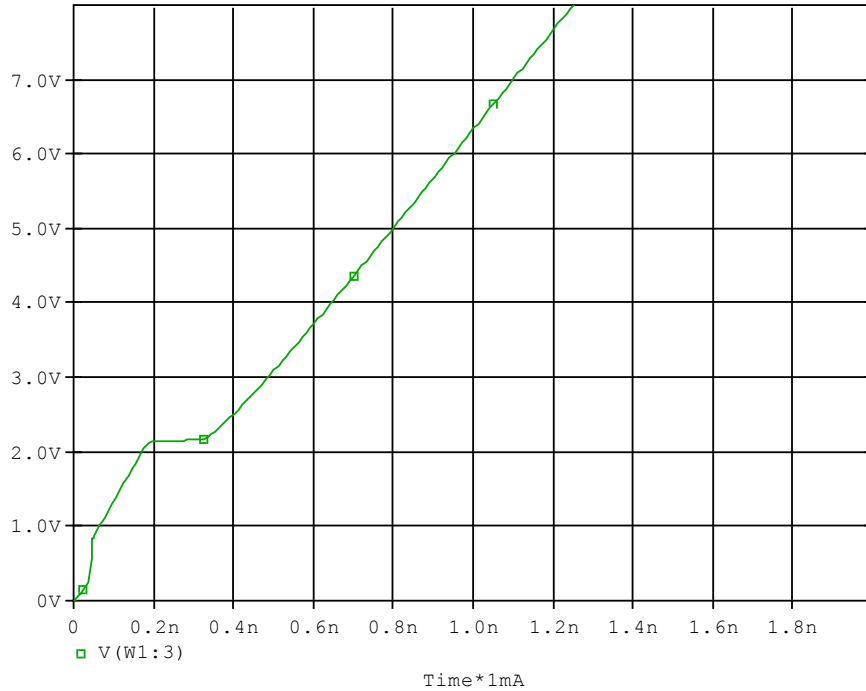

Evaluation circuit

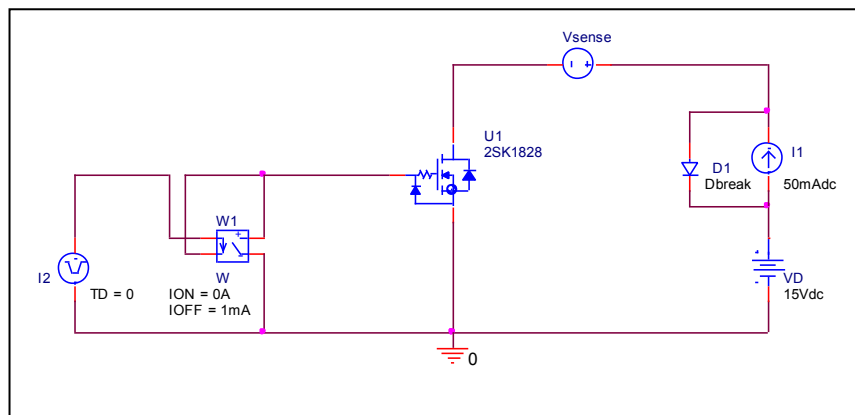

Simulation Result

$V_{DD}=15V,$ $I_D= 50mA$ $,V_{GS}=3V$	Measurement		Simulation		Error (%)
Qgs	0.2000	nC	0.2000	nC	0.0000
Qgd	0.1750	nC	0.1747	nC	- 0.1714

Gate Charge Characteristic

Reference

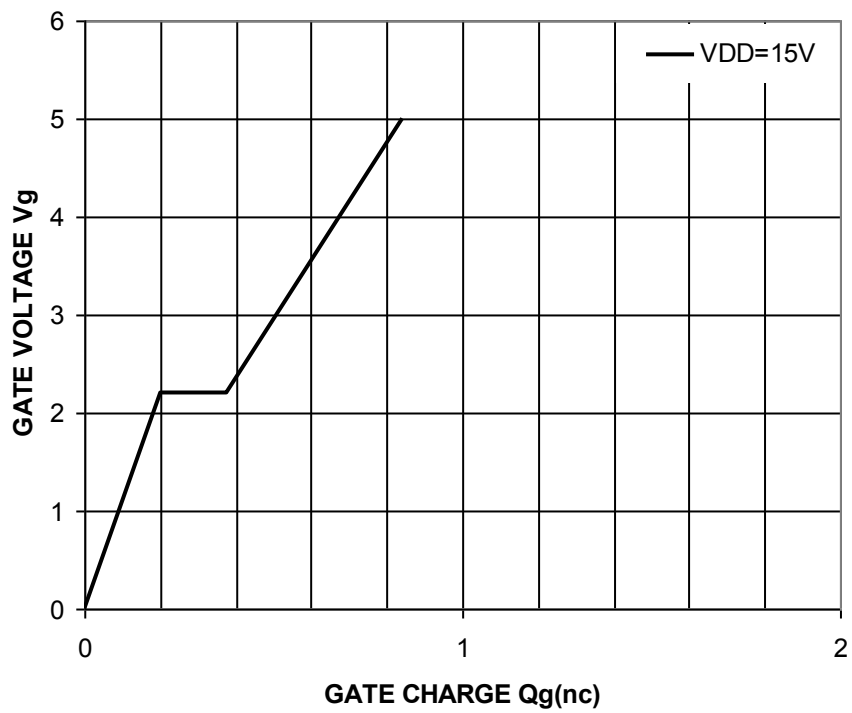

Capacitance Characteristics

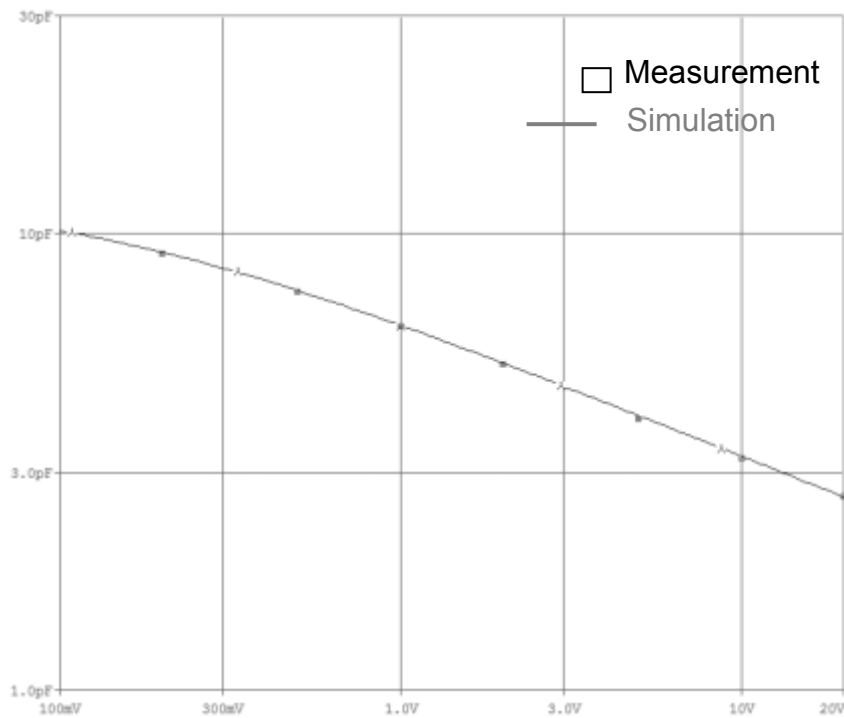

Simulation Result

V _{DS} (V)	Cbd(pF)		Error(%)
	Measurement	Simulation	
0.2	9.1000	9.1410	0.4505
0.5	7.5000	7.4903	- 0.1293
1	6.3000	6.2841	- 0.2524
2	5.2000	5.1938	- 0.1192
5	3.9500	3.9898	1.0076
10	3.2500	3.2574	0.2277
20	2.6800	2.6566	- 0.8731

Switching Time Characteristic

Circuit Simulation result

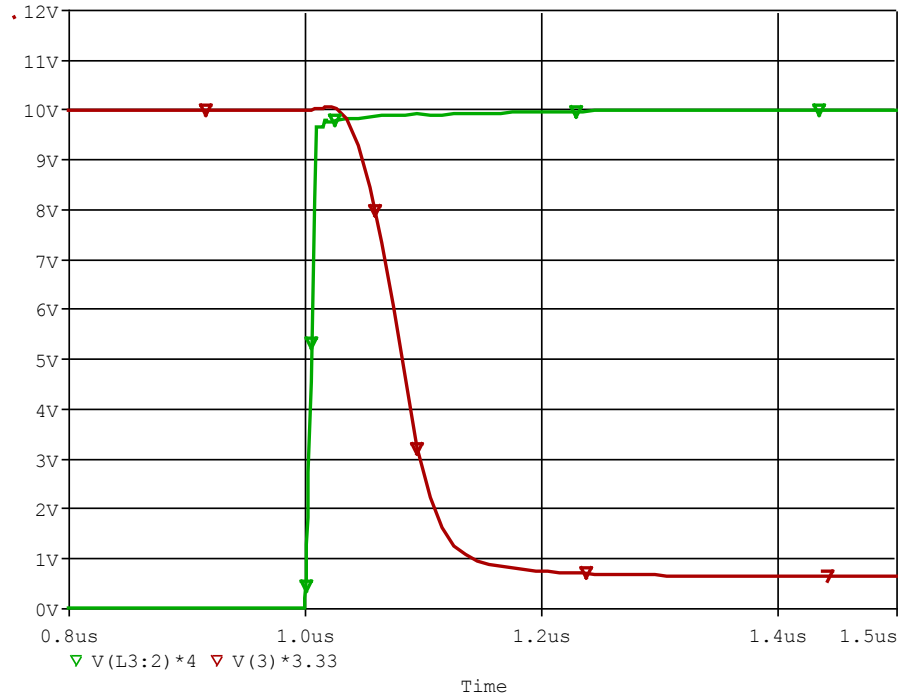

Evaluation circuit

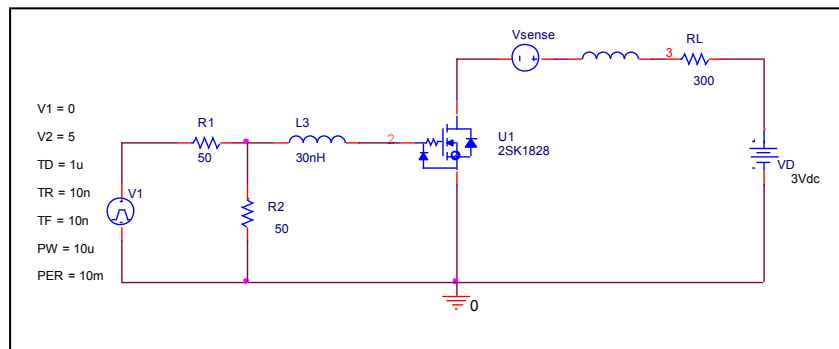

Simulation Result

$I_D=10\text{mA}$, $V_{DD}=3\text{V}$, $V_{GS}=0/0.25\text{V}$	Measurement		Simulation		Error(%)
	Td(on)	0.140 us	0.140249 us	us	
					0.1779

Output Characteristic

Circuit Simulation result

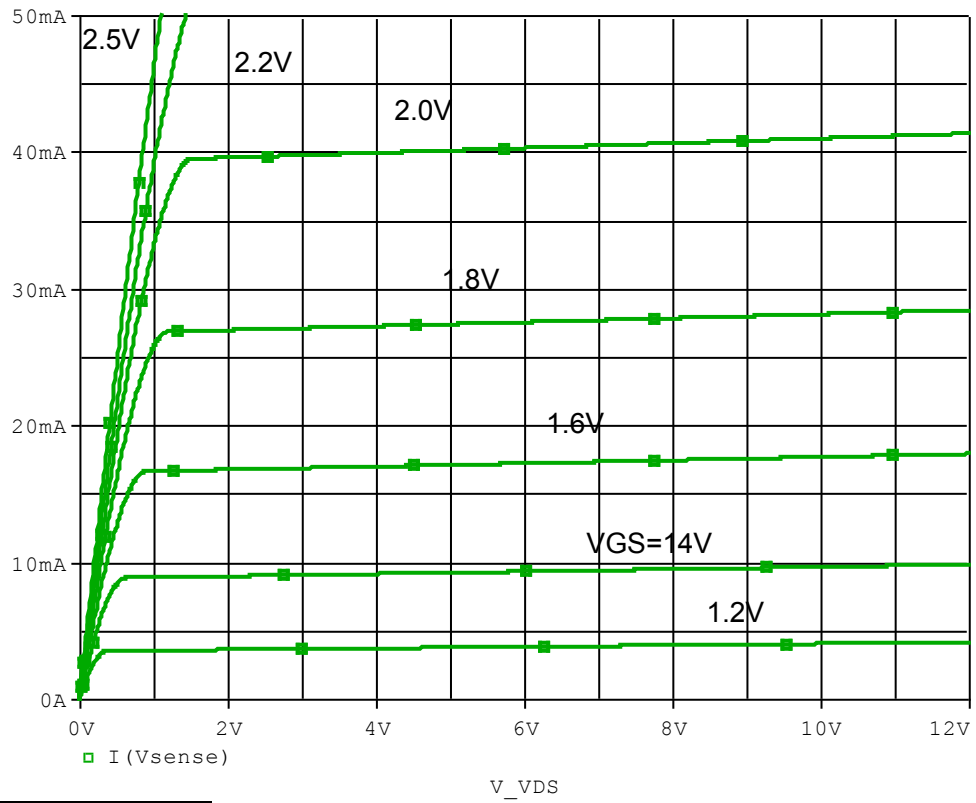

Evaluation circuit

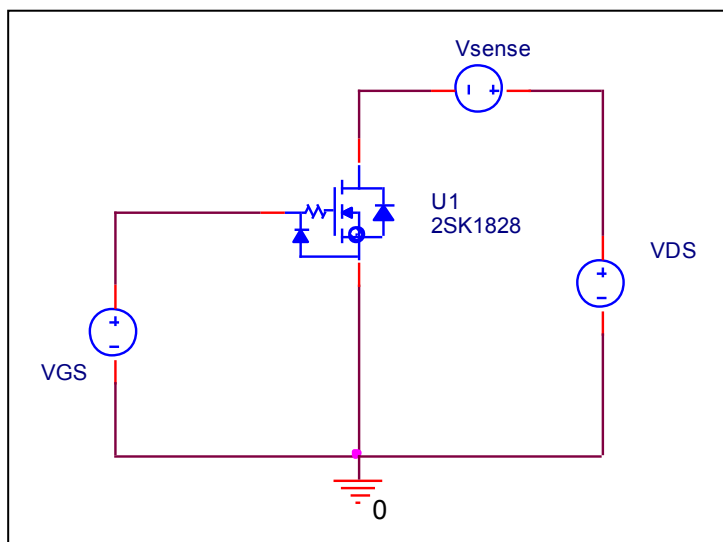

BODY DIODE SPICE MODEL

Forward Current Characteristic

Circuit Simulation Result

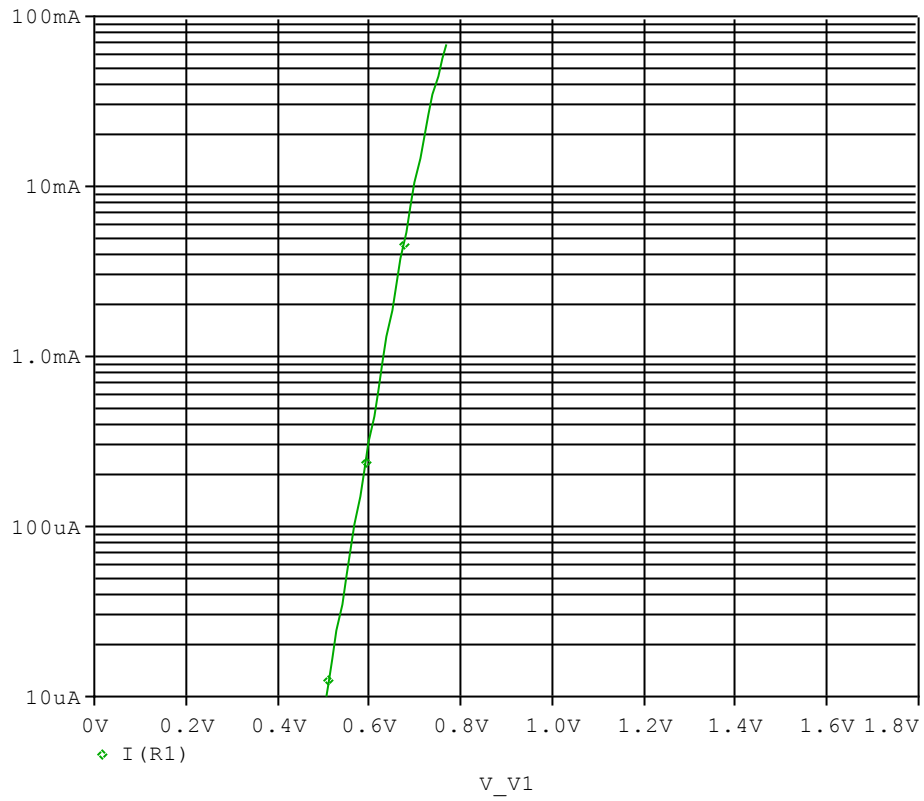

Evaluation Circuit

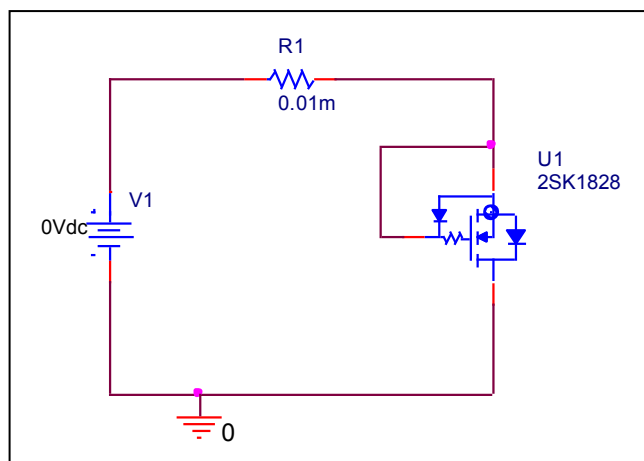

Comparison Graph

Circuit Simulation Result

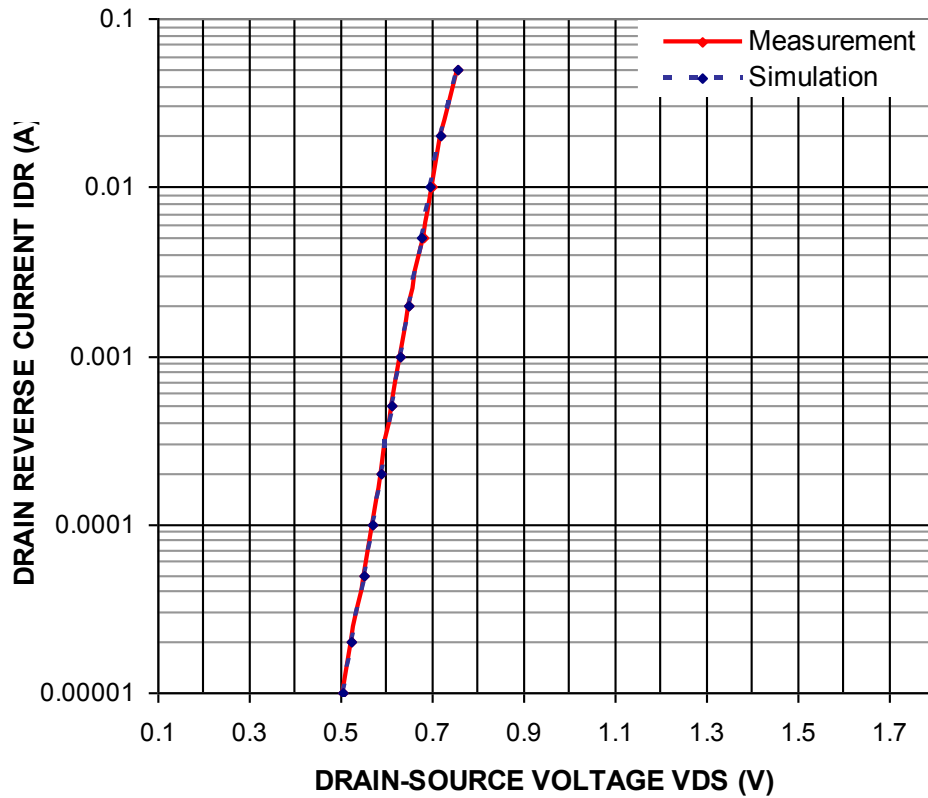

Simulation Result

IDR(A)	VSD(V)		%Error
	Measurement	Simulation	
0.0001	0.5700	0.5687	- 0.2281
0.0002	0.5900	0.5905	0.0847
0.0005	0.6120	0.6128	0.1307
0.001	0.6300	0.6321	0.3333
0.002	0.6500	0.6515	0.2308
0.005	0.6800	0.6776	- 0.3529
0.01	0.7000	0.6983	- 0.2429
0.02	0.7200	0.7205	0.0694
0.05	0.7550	0.7549	- 0.0132

Reverse Recovery Characteristic (Body Diode)

Circuit Simulation Result

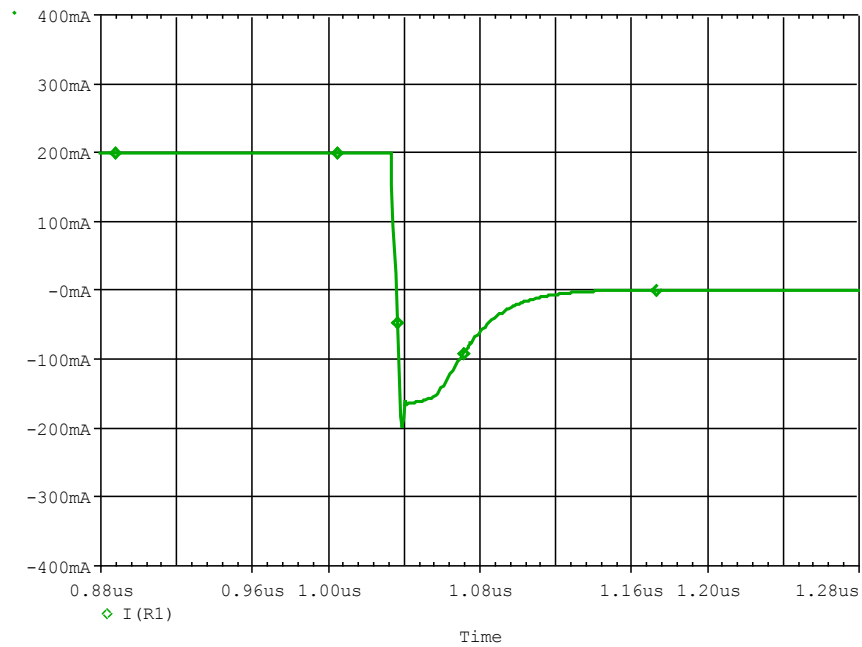

Evaluation Circuit

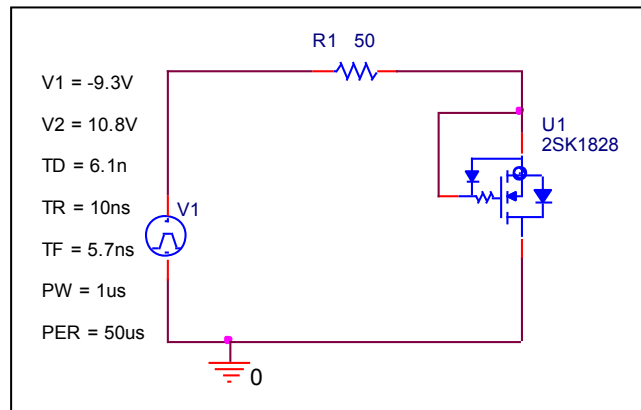

Compare Measurement vs. Simulation

	Measurement		Simulation		Error (%)
trj	84.8	ns	65.565	ns	-22.68

Reverse Recovery Characteristic (Body Diode)

Reference

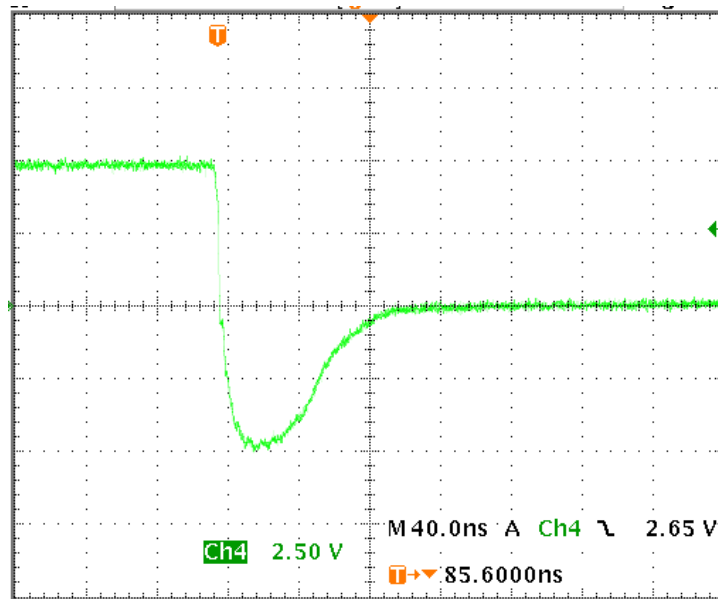

Trj= (26.4ns)
Trb= (58.4ns)
Conditions: Ifwd=Irev=0.2(A), RI=50

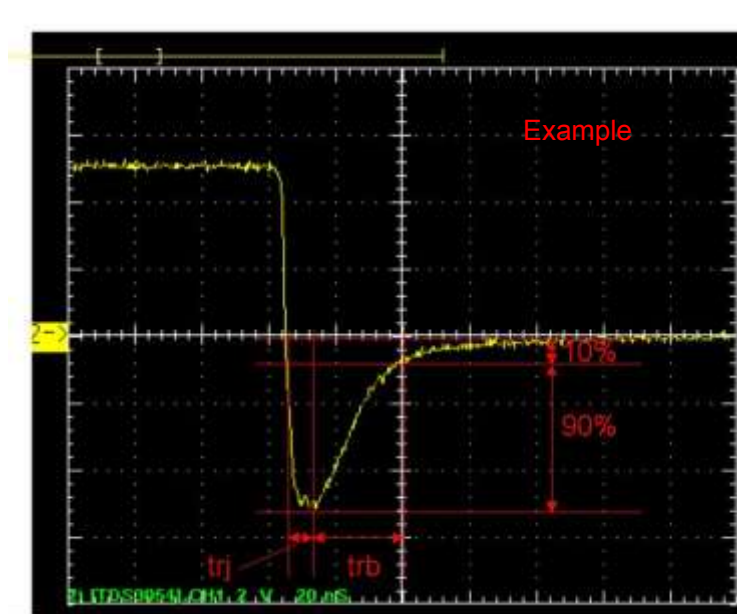

Relation between trj and trb

SOURCE-GATE DIODE SPICE MODEL (DSG) Forward Current Characteristic

Circuit Simulation Result

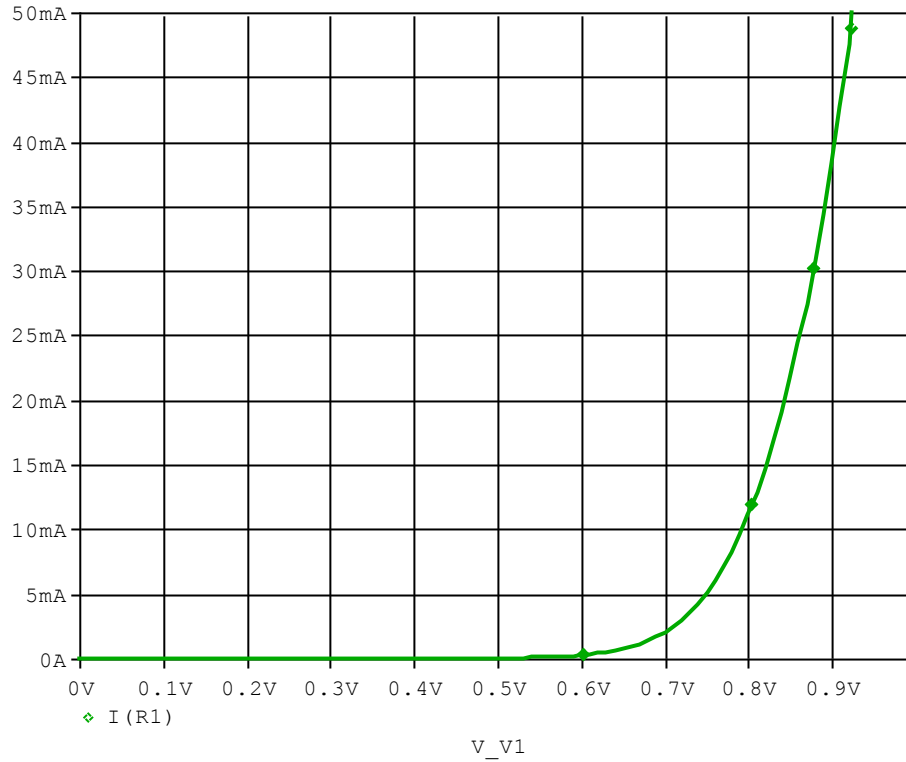

Evaluation Circuit

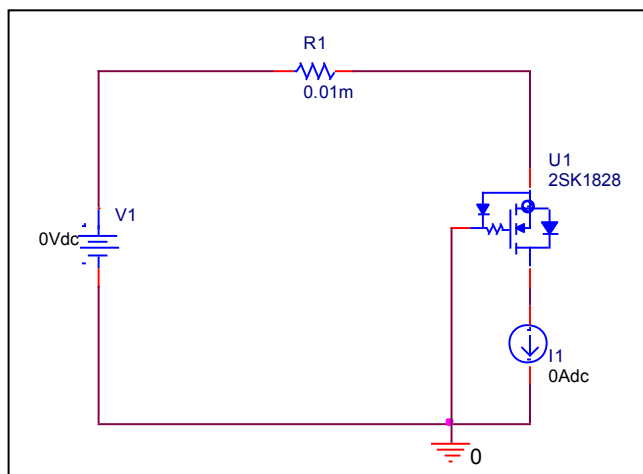

Comparison Graph

Circuit Simulation Result

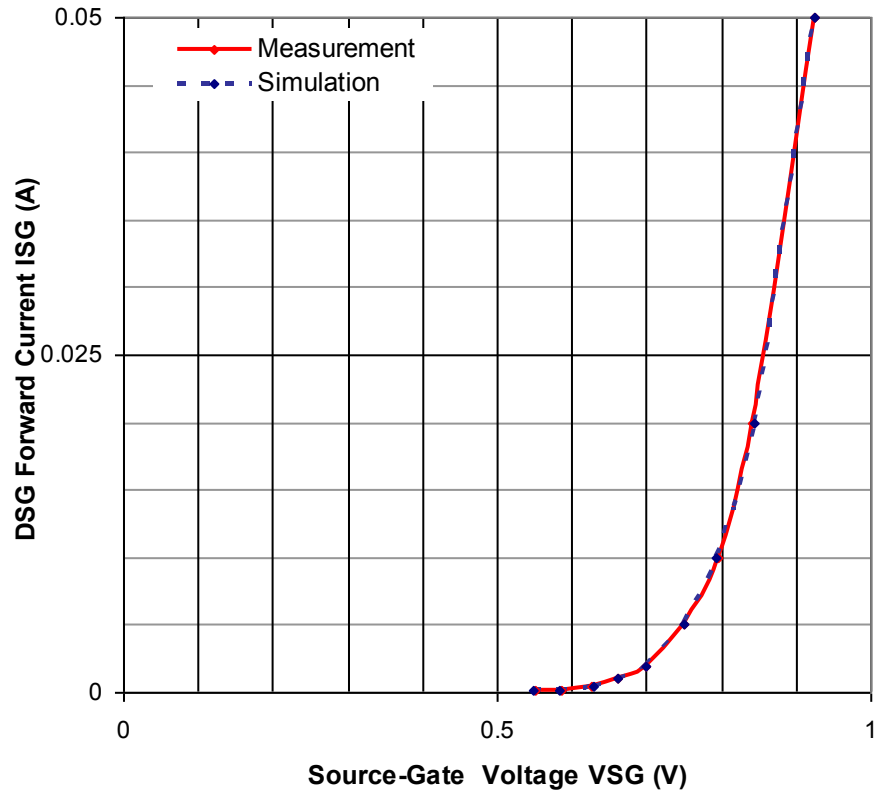

Simulation Result

ISG(A)	VSG(V)		%Error
	Measurement	Simulation	
0.0001	0.5500	0.5485	-0.27
0.0002	0.5850	0.5824	-0.44
0.0005	0.6250	0.6278	0.45
0.001	0.6600	0.6626	0.39
0.002	0.7000	0.6985	-0.21
0.005	0.7500	0.7492	-0.11
0.01	0.7960	0.7925	-0.44
0.02	0.8410	0.8434	0.29
0.05	0.9250	0.9245	-0.05

SOURCE-GATE DIODE SPICE MODEL (DSG)

Reference

