

# Skywire<sup>®</sup> BeagleBone Cape Lite

## Data Sheet

NimbeLink Corp

Updated: April 2017

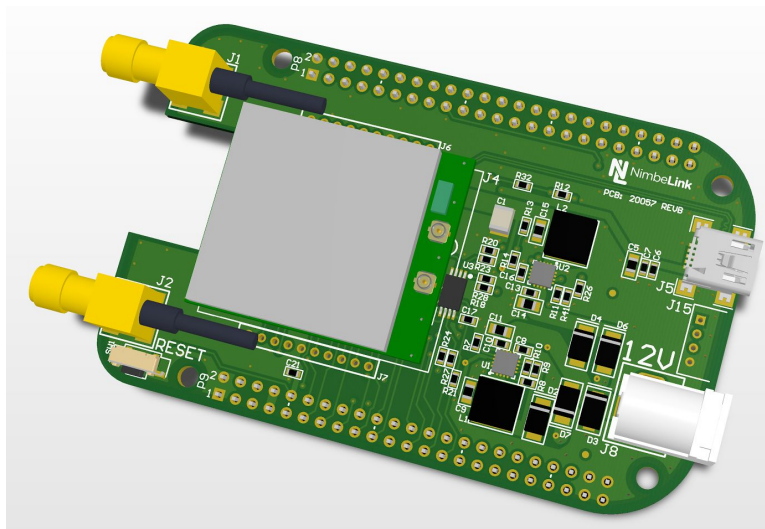

© NimbeLink Corp. 2017. All rights reserved.

NimbeLink Corp. provides this documentation in support of its products for the internal use of its current and prospective customers. The publication of this document does not create any other right or license in any party to use any content contained in or referred to in this document and any modification or redistribution of this document is not permitted.

While efforts are made to ensure accuracy, typographical and other errors may exist in this document. NimbeLink reserves the right to modify or discontinue its products and to modify this and any other product documentation at any time.

All NimbeLink products are sold subject to its published Terms and Conditions, subject to any separate terms agreed with its customers. No warranty of any type is extended by publication of this documentation, including, but not limited to, implied warranties of merchantability, fitness for a particular purpose and non-infringement.

NimbeLink is a registered trademark, and Skywire is a registered trademark, of NimbeLink Corp. All trademarks, service marks and similar designations referenced in this document are the property of their respective owners.

# Table of Contents

<b>Table of Contents</b>	<b>2</b>
<b>Introduction</b>	<b>2</b>
Overview	2
Product Description	3
Orderable Parts	3
Additional Resources	4
<b>Technical Specifications</b>	<b>4</b>
Block Diagram	4
Pinout	5
Mechanical Specifications	6
Electrical Specifications	7
Beaglebone Compatibility	8
Power Requirements	8
Antenna Specifications	8
Features	9
Skywire Cellular Modem	9
Grove Connectors	9
EEPROM	9
Device Tree Overlay	10

# 1. Introduction

## 1.1 Overview

This document is the data sheet for the Skywire® BeagleBone Cape Lite Development Kit. Throughout the document Skywire BeagleBone Cape Lite Development Kit will often be referred to as "the cape", although it may be referred to by its full name.

The NimbeLink Skywire modem is available with bundled data plans from leading cellular carriers. Visit [go.nimbelink.com](http://go.nimbelink.com) for cellular data plan details.

The Skywire cellular modem and antennas are sold separately.

Make sure you check the NimbeLink's Skywire Beaglebone Cape Lite product page for the most up to date information.

## 1.2 Product Description

The Skywire BeagleBone Cape Lite is a cape that allows easy access to the Internet of Things (IoT) via cellular connection. BeagleBone Black and BeagleBone Green are low-cost, community-supported development platforms that allows quick, easy application development. They accepts plug-in boards called "capes" that allow a wide variety of expanded capabilities. The Skywire BeagleBone Cape Lite supports any of NimbeLink's end-device certified Skywire plug-in cellular modems with optional bundled, no-contract cellular plans and in addition to cellular connectivity offers:

- Wide power supply input 5V-12V
- Compatible with: BeagleBone Black, BeagleBone Black Wireless BeagleBone Black Industrial, and BeagleBone Green
- BeagleBone Green Wireless can be used with additional standoffs
- Two user populatable Grove sensor interface for unlimited sensor flexibility

Fast, easy prototyping made possible by the Skywire BeagleBone Cape Lite.

## 1.3 Orderable Parts

Number	Description	Manufacturer	Carrier	Network Type
<a href="#">NL-AB-BBCL</a>	Skywire BeagleBone Cape Lite Development Kit	NimbeLink		
<a href="#">NL-SW-LTE-SVZM20-ES</a>	Skywire, 4G LTE CAT M1, Verizon, Engineering Sample	NimbeLink	Verizon	4G LTE
<a href="#">NL-SW-LTE-GELS3-C</a>	Skywire, 4G LTE CAT 1, Verizon	NimbeLink	Verizon	4G LTE
<a href="#">NL-SW-LTE-WM14</a>	Skywire, 4G LTE CAT 1, AT&T, T-Mobile	NimbeLink	AT&T, T-Mobile	4G LTE
<a href="#">NL-SW-LTE-TSVG</a>	Skywire, 4G LTE CAT 3, w/ GNSS, Verizon	NimbeLink	Verizon	4G LTE
<a href="#">NL-SW-LTE-TNAG-B</a>	Skywire, 4G LTE CAT 3, w/ GNSS, AT&T, T-Mobile	NimbeLink	AT&T, T-Mobile	4G LTE
<a href="#">NL-SW-LTE-S7588-T</a>	Skywire, 4G LTE CAT 4, AT&T, T-Mobile	NimbeLink	Verizon	4G LTE
<a href="#">NL-SW-LTE-S7588-V</a>	Skywire, 4G LTE CAT 4, Verizon	NimbeLink	AT&T, T-Mobile	4G LTE
<a href="#">TG.08.0113</a>	Monopole Cellular Antenna	Taoglas		
<a href="#">TG.30.8113</a>	Dipole Cellular Antenna	Taoglas		

## 1.4 Additional Resources

- [NimbeLink's Skywire Beaglebone Cape Lite Product Page](#)
- [NimbeLink's Skywire Beaglebone Cape Lite Device Tree Overlay](#)
- [NimbeLink's Skywire Beaglebone Cape Lite Schematic](#)
- [NimbeLink's Skywire Beaglebone Cape Lite Design Files](#)

## 2. Technical Specifications

### 2.1 Block Diagram

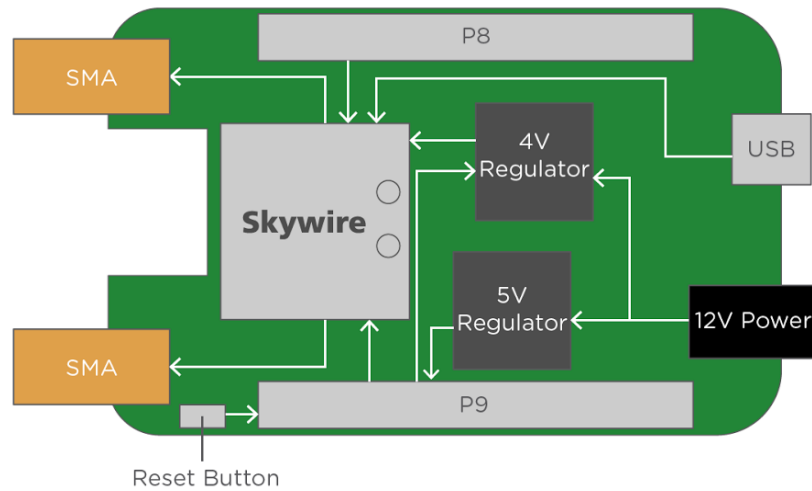

## 2.2 Pinout

The cape can use up to 19 GPIO in addition to the GND and VCC connections on the P8 (J10) and P9 (J13) headers.

PIN Name	Direction	GPIO Name	Connection	Notes
P9-11	Output	UART4_RXD	Skywire DOUT	
P9-13	Input	UART4_TXD	Skywire DIN	
P8-33	Input	UART4_RTS	Skywire RTS	
P8-35	Output	UART4_CTS	Skywire CTS	
P9-12	Input	GPIO1_28	Skywire DTR	
P9-15	Input	GPIO1_16	Skywire Reset	
P9-27	Input	GPIO3_19	Skywire ON-OFF	
P9-23	I/O	GPIO1_17	Skywire ADC	Not configured by DTO, not connected
P9-22	I/O	UART1_RXD	Skywire DIO2	Not configured by DTO, not connected
P9-24	I/O	UART1_TXD	Skywire DIO3	Not configured by DTO, not connected
P8-17	Input	GPIO_0_27	4V Regulator Enable	
P8-26	Output	GPIO1_29	4V Regulator PG	
P8-38	Output	UART5_RXD	Grove UART5 RX	Not configured by DTO
P8-37	Input	UART5_TXD	Grove UART5 TX	Not configured by DTO
P9-17	Input	I2C1_SCL	Grove I2C1 SDA	Not configured by DTO
P9-18	I/O	I2C1_SDA	Grove I2C1 SCL	Not configured by DTO
P9-19	Input	I2C2_SCL	I2C2 SCL	
P9-20	I/O	I2C2_SDA	I2C2 SDA	
P9-25	Input	GPIO3_21	EEPROM WP	Default Pulled High

## 2.3 Mechanical Specifications

Mechanical Specifications	
Parameter	Value
Mechanical Size	97x55x22mm
PCB Layers	4
PCB Thickness	1.6mm
RoHS	Yes

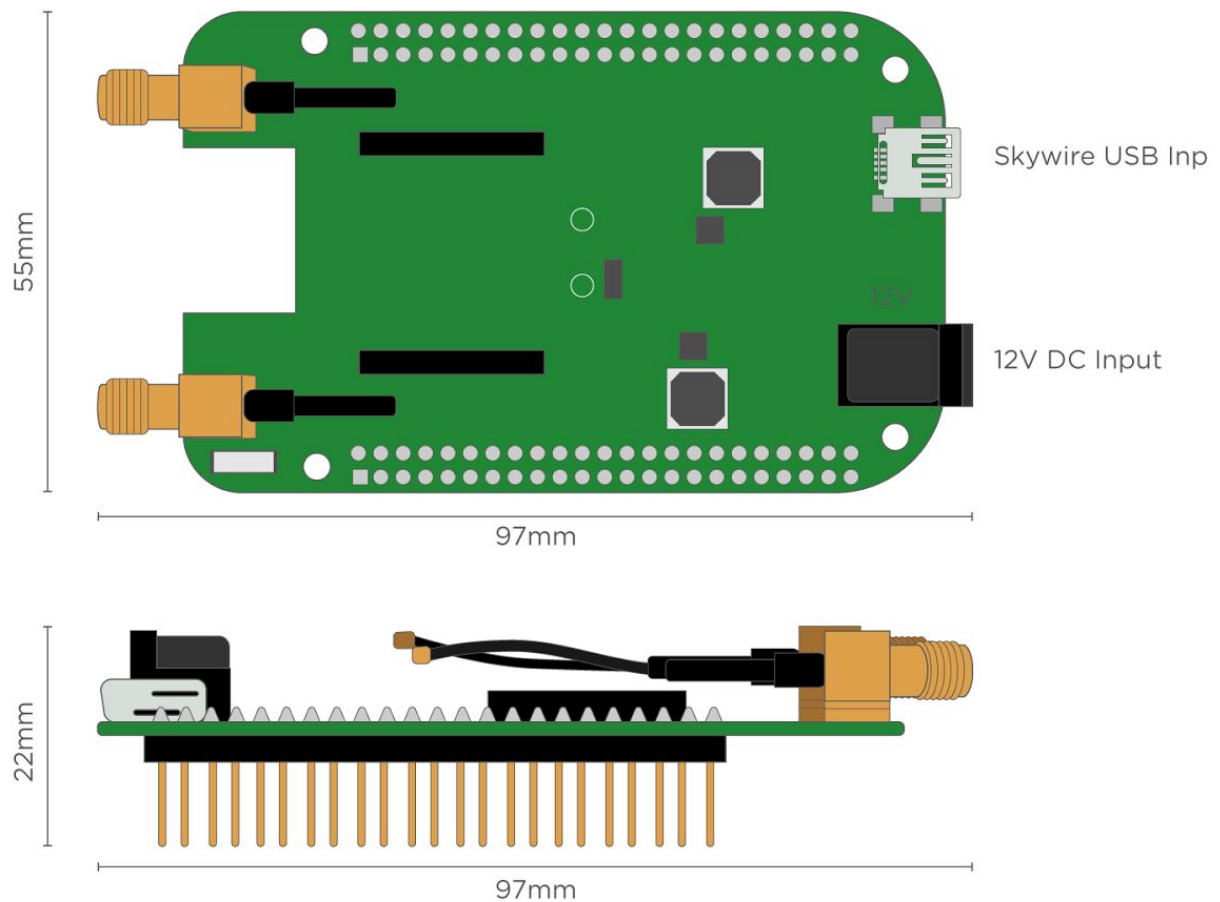

## 2.4 Electrical Specifications

Electrical Specifications				
Parameter	Min	Typ	Max	Unit
J8 Input Voltage	6	12	15	V
J8 Current Requirements	1.6	1.6		A
VDD_5V Current Requirements (if powered by Beaglebone)	1.5	2		A
VDD_5V_SYS	0	0		A
VCC_3V3	3	4		mA

## 2.5 Beaglebone Compatibility

NimbeLink's Skywire BeagleBone Cape has been designed to be drop in compatible with the following Beagle Bones:

- BeagleBone Black
- BeagleBone Black Wireless
- BeagleBone Black Industrial
- BeagleBone Green

Users using the BeagleBone Green Wireless will need to use stand off headers to provide additional clearance over the BeagleBone Green Wireless USB connectors. NimbeLink recommends the following stand-off headers:

- [Adafruit 706](#)
- [Major League Electronics SSHQ-123-D-08-GT-LF](#)

Users will need to ensure they have updated their device tree to the latest version to ensure the cape's device tree overlay (DTO) has been installed.

## 2.6 Power Requirements

The cape's primary power path is through the cape's DC barrel jack (J8). The cape will accept a DC input of 6-15V. NimbeLink recommends using a 12V DC 1.6A supply such as the CUI Inc. [SW118-12-N-P6](#). When using the primary power input on the cape an onboard DC switching regulator will supply 5V/2A to the attached BeagleBone.

If 12V is not available the cape can draw from the VDD\_5V pins on P9 to power the Skywire. This feature is available for BeagleBones that connect the 5V barrel jack to the VDD\_5V pins such as the Beaglebone Black and BeagleBone Black Wireless. Users using the Beaglebone Green will need to power the cape through the 12V interface as the Beaglebone green does not connect the 5V USB input to the VDD\_5V pins.



Due to the amperage limitations of typical USB ports, the cape should not be powered from a PC's USB port. The available power is insufficient to power most Skywire modems, which can cause damage and void the warranty.

## 2.7 Antenna Specifications

The SMA connectors are connected to the PCBs ground plane, This allows for mono-pole antennas, such as a Taoglas TG.08.0113, to be used.

For optimum performance a dipole antenna, such as a Taoglas [TG.30.8113](#) antenna, is recommended.

## 2.8 Features

NimbeLink's Skywire Beaglebone Black Cape is designed to be a low cost, adaptable cellular gateway for the BeagleBone development platforms. The cape enables diverse connectivity options by including a Skywire Cellular Modem socket for cellular/GPS connections, allowing users to use any of NimbeLink's 2G, 3G, or 4G Skywire modems.

### 2.8.1 Skywire Cellular Modem

The cape's Skywire socket allows for the Skywire cellular modem to communicate with the Beaglebone Black development kit over UART or through a USB connection. The Skywire's 20-pin form factor allows for compatibility across all of the Skywire product line and interchangeability between 2G, 3G, and 4G cellular technologies.

### 2.8.2 Grove Connectors

There are two user populatable Grove Connectors onboard the cape that allow users to attach additional digital Grove compatible sensors. Users will need to order and solder the connectors in place if they wish to use them. NimbeLink recommends using JST's [S4B-PH-K-S\(LF\)\(SN\)](#).

Grove connector J15 connects to UART5 and connector J16 connects to I2C1. The cape's DTO does not load pin configurations for J15 or J16, but many distributions will automatically configure I2C1 at boot.

## 2.8.3 EEPROM

The cape has an onboard EEPROM containing the cape's device tree overlay information per the Beaglebone EEPROM Data Format Revision A1. By default the EEPROM has write protection enabled to protect the EEPROM from data corruption, but if users need to modify the EEPROM or would like to use the free space on the EEPROM they can control the WP pin using GPIO3\_21. The EEPROM is configured by default to use I2C2 address 0x56.

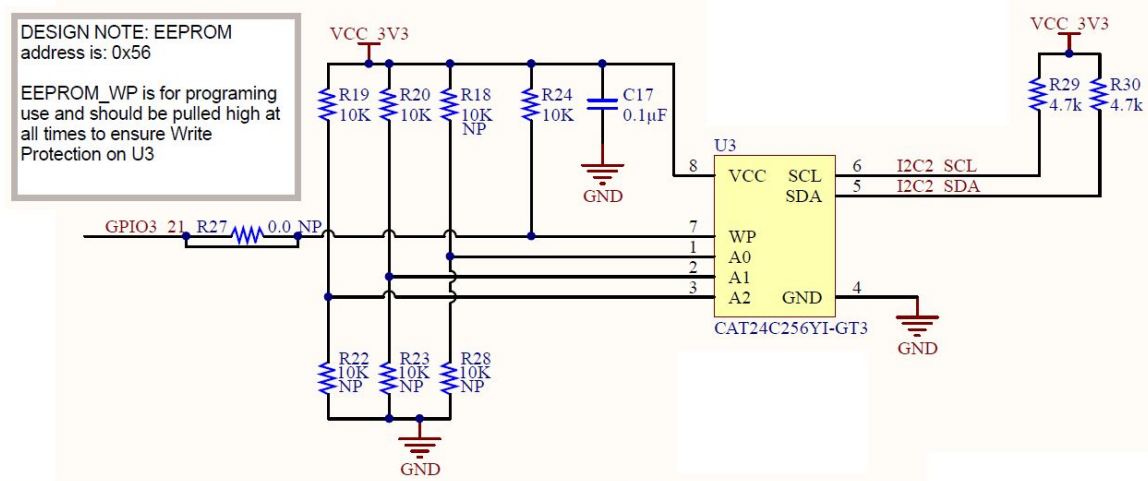

## 2.8.4 Device Tree Overlay

The cape's onboard EEPROM contains information that will automatically configure the Beaglebone's device tree to enable the cape's required pins. The most recent device tree overlay can be downloaded [here](#). The device tree will automatically configure the following:

Pin	Configuration	Use	I/O	Initialized Value
P9.11	UART4_RXD	UART4_RXD	I	
P9.13	UART4_TXD	UART4_TXD	O	
P8.33	UART4_RTS	UART4_RTS	O	Low
P8.35	UART4_CTS	UART4_CTS	I	
P8.17	GPIO0_27	Sky_PWR_EN	O	High
P8.26	GPIO1_29	Sky_PWR_PG	I	
P9.12	GPIO1_28	Sky_DTR	O	Low
P9.15	GPIO1_16	Sky_Reset	O	Low
P9.25	GPIO3_21	EEPROM_WP	O	High
P9.27	GPIO3_21	Sky_On_Off	O	High