

PRODUCT NUMBER
SEE PART NO. TABLE

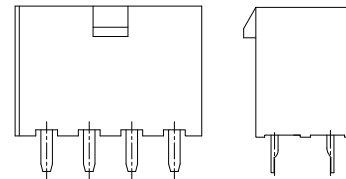
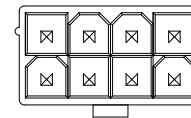
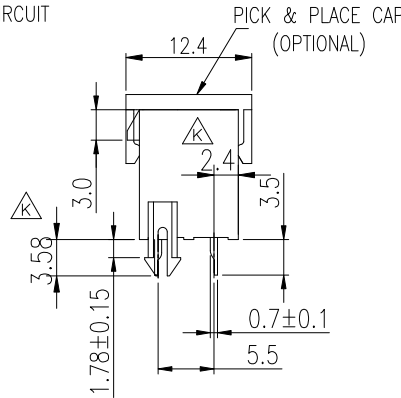
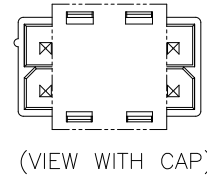
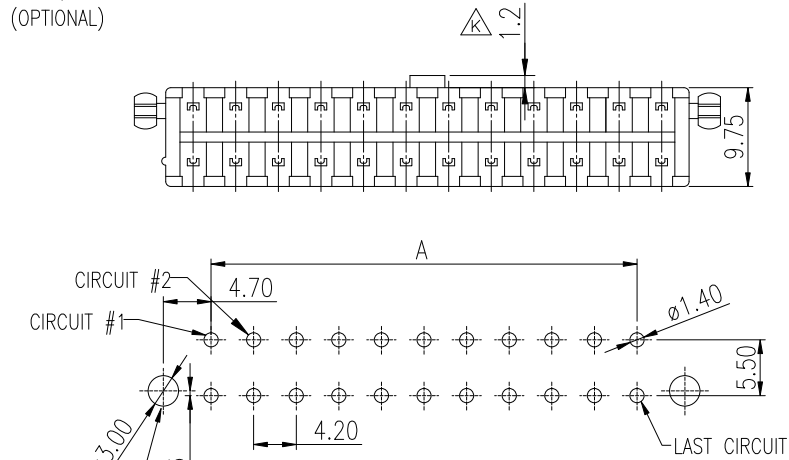
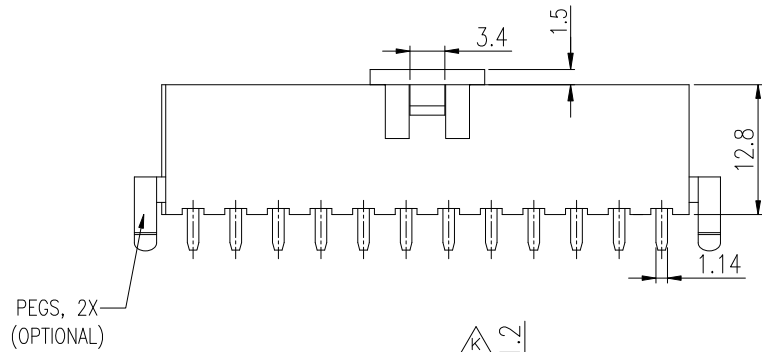
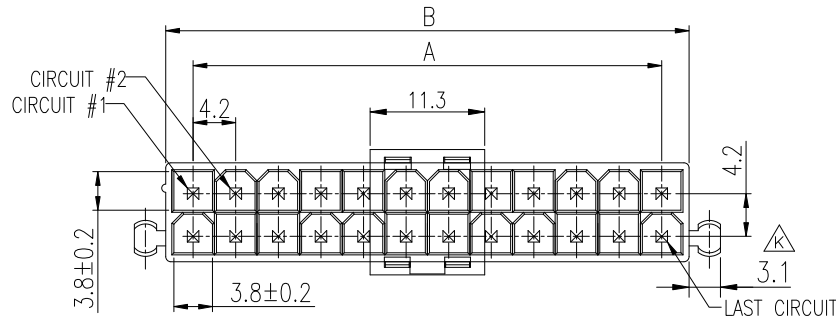

PART WITHOUT PEGS

NOTES:

- MATERIAL:
HSG: OPTIONAL, UL94V-0.
COLOR: NATURAL.
TERMINAL: BRASS.
PLATING: 50u" Ni UNDERPLATING; OPTIONAL ON CONTACT AREA.
PICK & PLACE CAP: HIGH TEMP. THERMOPLASTIC
- THIS PLUG MATES WITH FCI RECEPTACLE WIRE CONNECTOR 10127815.
- PRODUCT SPECIFICATION: GS-12-1181.
- PACKAGE SPECIFICATION: GS-14-2362.
- THE HOUSING WILL WITHSTAND EXPOSURE TO 235°C PEAK TEMPERATURE FOR 5 SECONDS IN A WAVE SOLDER APPLICATION WITH A 1.6mm MINIMUM THICK CIRCUIT BOARD. (FOR PA66)
THE HOUSING WILL WITHSTAND EXPOSURE TO 260 °C PEAK TEMPERATURE FOR 10 SECONDS IN A REFLOW OVEN. (FOR LCP ONLY)
- PART NUMBER SCHEME:
10127820- XX X X X X X LF
POS. CODE:
02: 2 POS.
04: 4 POS.
24: 24 POS.
TERMINAL MATERIAL:
2: BRASS
PLATING CODE:
1: GOLD FLASH
2: TIN
4: 30u" Au
S: GOLD FLASH ON ONCONTACT, MATTE TIN ON TAILS
CAP: (NOT APPLICABLE FOR 2 POS.)
BLANK: NO CAP, TRAY PACKAGE
C: WITH CAP, TAPE/REEL PACKAGE
PEG:
BLANK: NO PEG
P: 2 PEGS
GLOW WIRE COMPATIBLE:
BLANK: PA66, NON COMPATIBLE
G: PA66, COMPATIBLE
L: LCP, COMPATIBLE

7. DIMENSIONAL & PART NO. TABLE:

PART NUMBER	POS.	A	B
10127820-02XXXXLF	02	4.2	5.4
10127820-04XXXXLF	04	4.2	9.6
10127820-06XXXXLF	06	8.4	13.8
10127820-08XXXXLF	08	12.6	18.0
10127820-10XXXXLF	10	16.8	22.2
10127820-12XXXXLF	12	21.0	26.4
10127820-14XXXXLF	14	25.2	30.6
10127820-16XXXXLF	16	29.4	34.8
10127820-18XXXXLF	18	33.6	39.0
10127820-20XXXXLF	20	37.8	43.2
10127820-22XXXXLF	22	42.0	47.4
10127820-24XXXXLF	24	46.2	51.6

mat'l. code		surface		tolerance		projection		product family	
ltr		ecn no		dr		date		Minitek Pwr4.2	
H		ELX-T-20468		TAI		2015-03-16		title	
J		ELX-T-21113		TAI		2015-06-09		MINITEK PWR4.2, WT B HEADER,	
K		ELX-T-21843		TAI		2016-06-02		DUAL ROW, VERTICAL, DIP TYPE	
E		ELX-T-17590		TAI		2014-04-29		scale	
F		ELX-T-19251		TAI		2014-10-31		dwg no	
G		ELX-T-20255		TAI		2015-02-12		sheet 1 of 2	
sheet		revision		K		K		size	
index		sheet		1		2		A4	
								10127820	
								CUSTOMER Drawing	
								type	

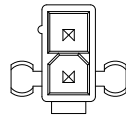

2 POS

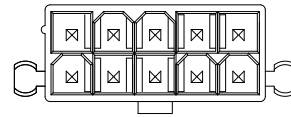

10 POS

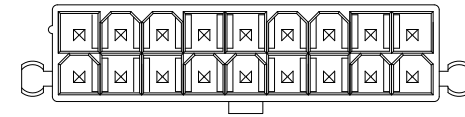

18 POS

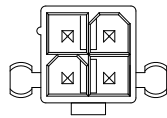

4 POS

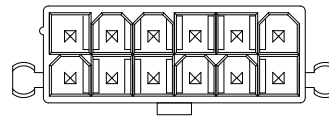

12 POS

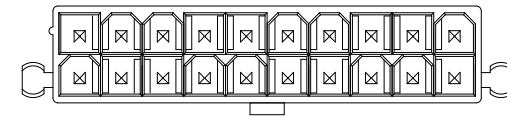

20 POS

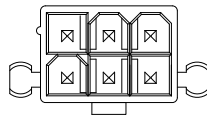

6 POS

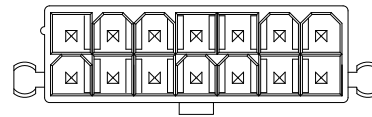

14 POS

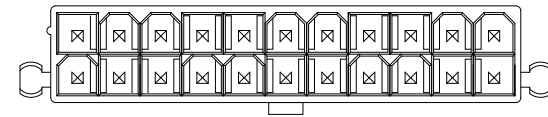

22 POS

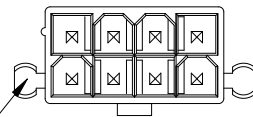

8 POS

WITH PEG

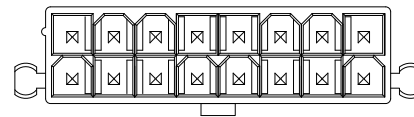

16 POS

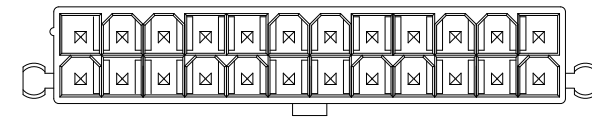

24 POS

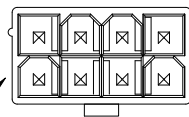

VIEW WITHOUT PEG

NO PEG

mat'l. code		surface	tolerance	projection	product family
ltr		tolerances unless otherwise specified		 MM	Minitek Pwr4.2
ecn no	dr	date	angles		title
			X.X ±0.4	 scale	MINITEK PWR4.2, WTB HEADER, DUAL ROW, VERTICAL, DIP TYPE
			X.XX ±0.3		
			X*±1"		
			dr	KENNY TAI	2013-11-11
			enr	KENNY TAI	2013-11-11
			chr	KENNY TAI	2013-11-11
			appd	PM ZHENG	2013-11-22
sheet index	revision sheet	K	K		
		1	2		



dwg no	sheet 2 of 2	size
10127820		A4
type	CUSTOMER Drawing	