

All dimensions are in mm; tolerances acc. ISO 2768 m-H.

Documents

Tape & reel packaging VG132.85000

Material and plating

Connector parts

Piston
Ferrule
Spring
Dielectric

Material

Brass
Brass
Stainless steel (1.4310)
LCP

Plating

3 µm Ni / 0.15 µm Au
3 µm Ni / 0.15 µm Au

Electrical data

Impedance 50 Ω
 Frequency DC to 6 GHz
 Return loss ≥ -32 dB, DC to 2 GHz
 ≥ -27 dB, 2 to 4 GHz
 ≥ -20 dB, 4 to 6 GHz
 Insertion loss ≤ 0.04 x √f(GHz) dB
 Insulation resistance ≥ 5 x10³ MΩ
 Contact resistance ≤ 25 mOhm after 5 cycles with operational stroke
 Test voltage 1000 V rms
 Working voltage 480 V rms
 Power handling (at 20 °C, sea level, VSWR 1.0) ≤ 100 W @ 2 GHz
 RF-leakage ≥ 40 dB up to 6 GHz
 - VSWR in application depends decisive on PCB layout -

Mechanical data

Durability > 1,000
 Max. pin travel 0,6 mm
 Nominal height 4,2 mm
 Travel vs Force At 0.1 mm F1 = 0.2 N ±0.1 N
 At 0.6 mm F2 = 0.7 N ± 0.1 N

Environmental data

Operational temperature -40°C to +90°C
 Storage temperature (*) -55 °C to +100 °C
 Salt mist (*) IEC 60068-2-52
 Duration 48h
 NaCl-saturation 5% of Mass
 ph-value 6.5-7.2 @ 35±2°C
 Cycle test Measure resistance
 1,000 cycles
 Measure resistance
 Max. soldering temperature IEC 61760-1, +260°C for 10 sec.
 2002/95/EC (RoHS) compliant

PCB Layout

Cu layer (top)

Solder resist layout (top)

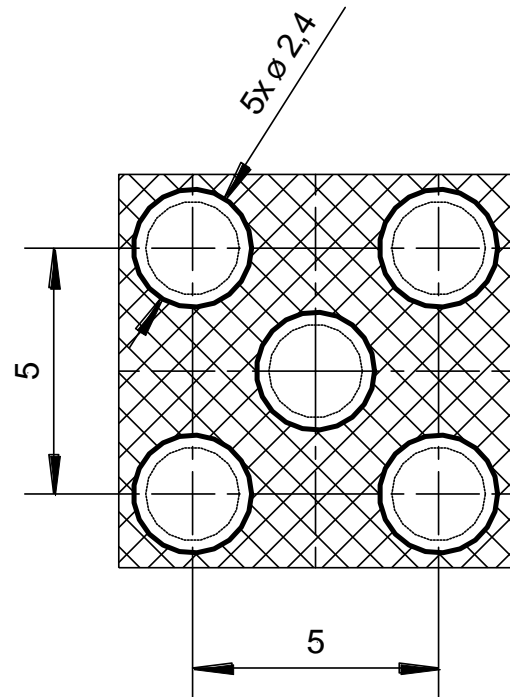
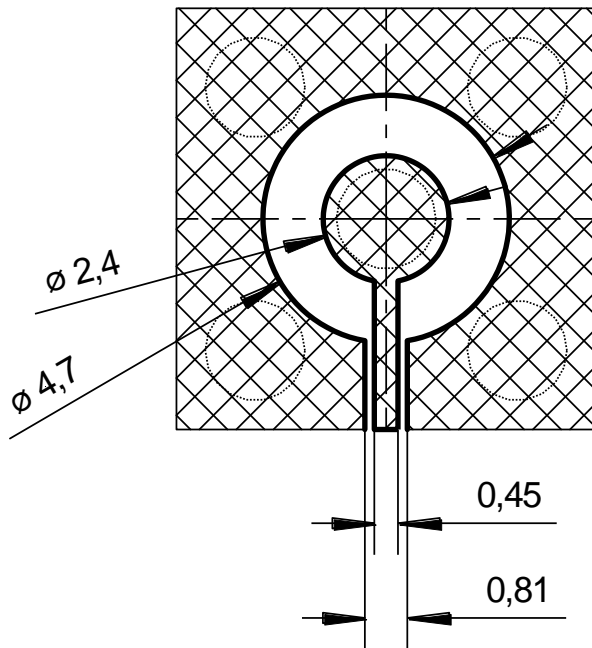

Leiterplattenmaterial: FR 4
 Cu-Schichtdicke 0,35µm
 Oberfläche Hartvergoldet

A wide variety of transmissionline topologies and pcb-parameters like permittivity, substrate thickness, and board-stackup are applied by customers. These parameters have a strong impact on the high frequency performance of the mounted connector. Please note, that the given layout is not optimised to fit all of the possible board configurations regarding RF-performance, it represents a recommendation for optimum solderability of the connector. In order to guarantee optimum high frequency properties of the connector, an RF-analysis of the connector to board transition is recommended.

Packing

Standard 50 pcs Blister
 Weight 0.35 g/pcs

While the information has been carefully compiled to the best of our knowledge, nothing is intended as representation or warranty on our part and no statement herein shall be construed as recommendation to infringe existing patents. In the effort to improve our products, we reserve the right to make changes judged to be necessary.

Draft	Date	Approved	Date	Rev.	Engineering change number	Name	Date
C. Kainzmaier	03/07/17	C. Kainzmaier	03/07/17	b01	17-0004	C. Kainzmaier	03/07/17