

# NHD-5.7-320240WFB-ETXI#-T-1

## TFT (Thin-Film-Transistor) Color Liquid Crystal Display Module

NHD-	Newhaven Display
5.7-	5.7" Diagonal
320240-	320xRGBx240 Pixels
WFB-	Model
E-	Built-in Driver + Controller (16-bit)
T-	White LED Backlight
X-	TFT
I-	6:00 Optimal View, Wide Temp.
#-1	<b>RoHS Compliant</b>
T-	Touch Panel

**Newhaven Display International, Inc.**

2661 Galvin Ct.

Elgin IL, 60124

Ph: 847-844-8795

Fax: 847-844-8796

[www.newhavendisplay.com](http://www.newhavendisplay.com)

[nhtech@newhavendisplay.com](mailto:nhtech@newhavendisplay.com)

[nhsales@newhavendisplay.com](mailto:nhsales@newhavendisplay.com)

## Document Revision History

Revision	Date	Description	Changed by
0	7/8/2009	Initial Release	CL
1	7/29/2009	MECHANICAL DRAWING UPDATE	CL
2	11/4/2009	Quality Information Update	BE
3	3/26/2010	Pin Description Update	MP
4	5/24/2011	Electrical characteristics updated	AK
5	1/6/2012	Pixel data format updated	AK
6	5/15/2012	Touch panel pin description updated	AK
7	7/17/2012	Mechanical drawing updated	AK
8	1/10/17	Mech. Drawing, Electrical and Optical Characteristics Updated	TM
9	2/6/17	Electrical Characteristics Updated	TM

## Functions and Features

- 320xRGBx240 resolution
- LED backlight
- 8-bit parallel interface
- SSD1963 Controller

# Mechanical Drawing

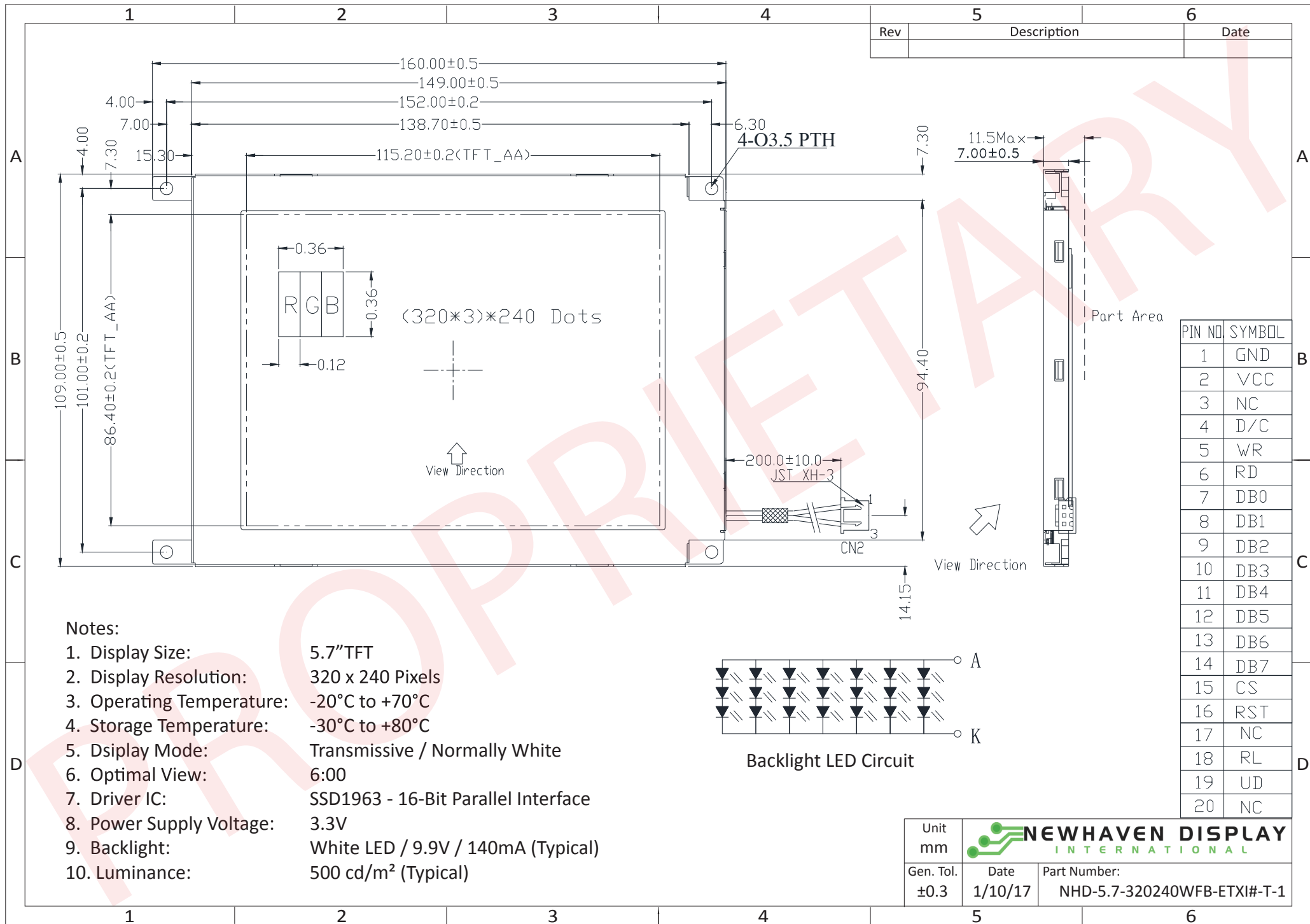

# Mechanical Drawing

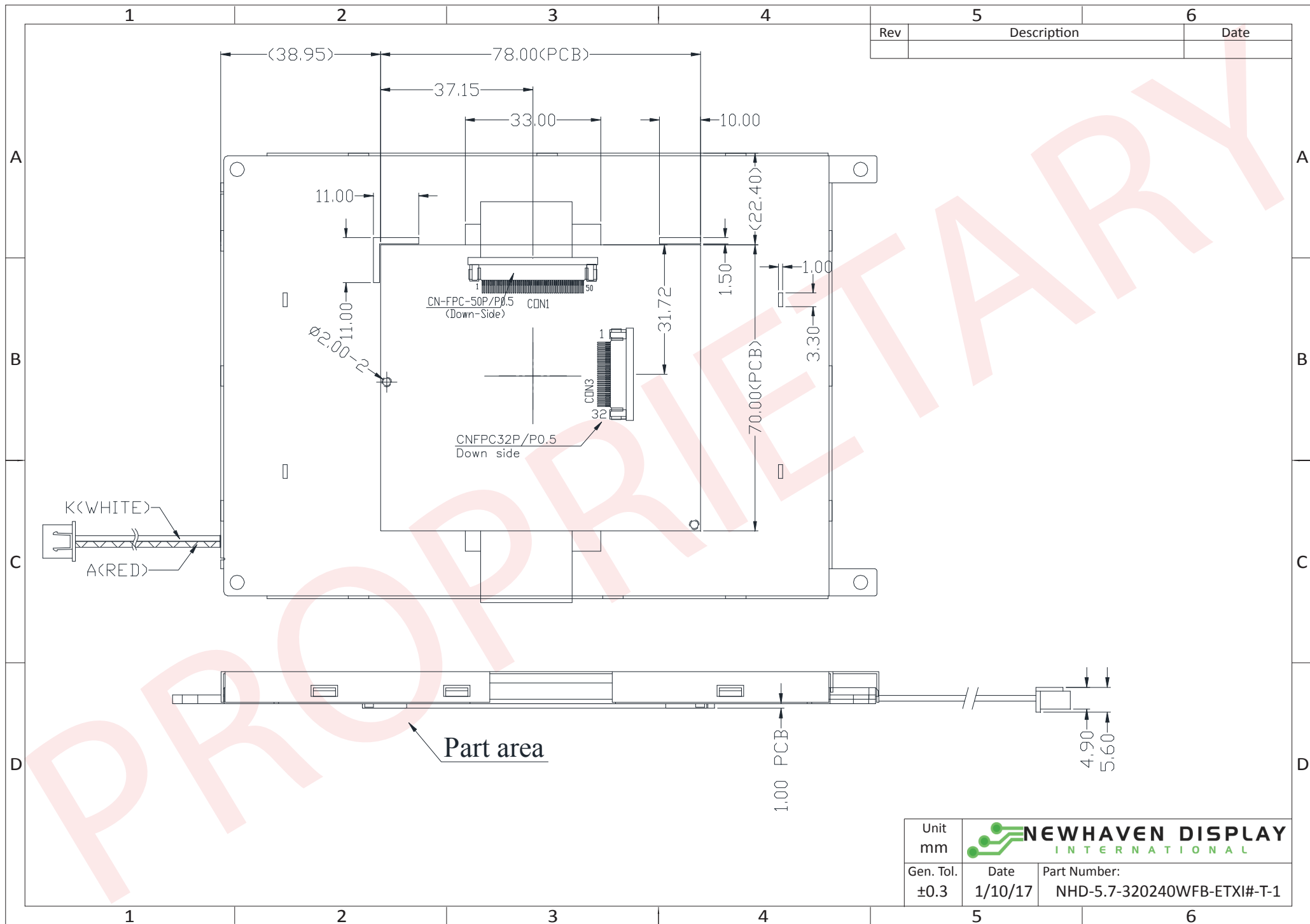

Rev	Description	Date

Unit mm		
Gen. Tol. ±0.3	Date 1/10/17	Part Number: NHD-5.7-320240WFB-ETXI#-T-1

The information contained herein is the exclusive property of Newhaven Display International, Inc. and shall not be copied, reproduced, and/or disclosed in any format without permission.

# Touch Screen Mechanical Drawing

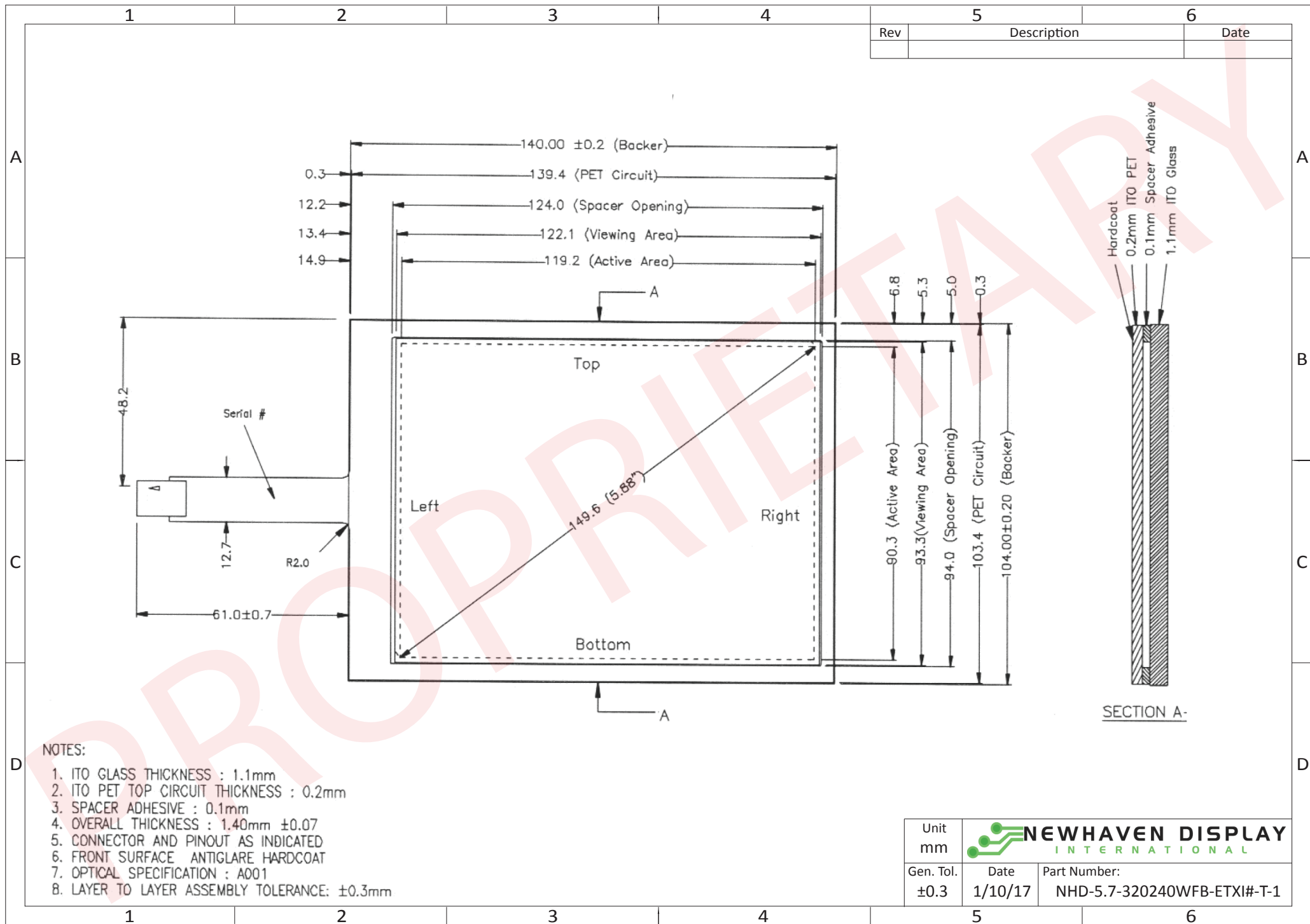

Unit mm		
Gen. Tol. ±0.3	Date 1/10/17	Part Number: NHD-5.7-320240WFB-ETXI#-T-1

# Pin Description

## CON2:

Pin No.	Symbol	External Connection	Function Description
1	GND	Power Supply	Ground
2	VCC	Power Supply	Power supply for LCD and logic (3.3V)
3	NC	-	No Connect
4	D/C#	MPU	Register Select signal – : 1=Data , 0=Command
5	WR#	MPU	Active LOW Write signal, 8080 MPU interface
6	RD#	MPU	Active LOW Read signal, 8080 MPU interface
7-22	[DB0-DB15]	MPU	Bi-directional data bus lines
23	NC	-	No Connect
24	NC	-	No Connect
25	CS#	MPU	Active LOW Chip Select signal
26	RES#	MPU	Active LOW Reset signal
27	R/L	-	Scan direction 1: Right (Tied internally)
28	U/D	-	Scan direction 0: Down (Tied internally)
29-32	NC	-	No Connect

**Recommended LCD connector:** 0.5mm pitch 32-Conductor FFC. Hirose p/n FH12A-32S-0.5SH(55)

**Backlight connector:** JST p/n: XHP-3 **Mates with:** JST p/n: S3B-XH-SM3-TB

## Backlight:

Pin No.	Symbol	External Connection	Function Description
1	V <sub>DD</sub>	Power Supply	Red, LED Anode (140mA @ 9.9V)
2	NC	-	No Connect
3	GND	Power Supply	White, LED Cathode

**Backlight connector:** JST p/n: XHP-3 **Mates with:** JST p/n: B 3B-XH-A

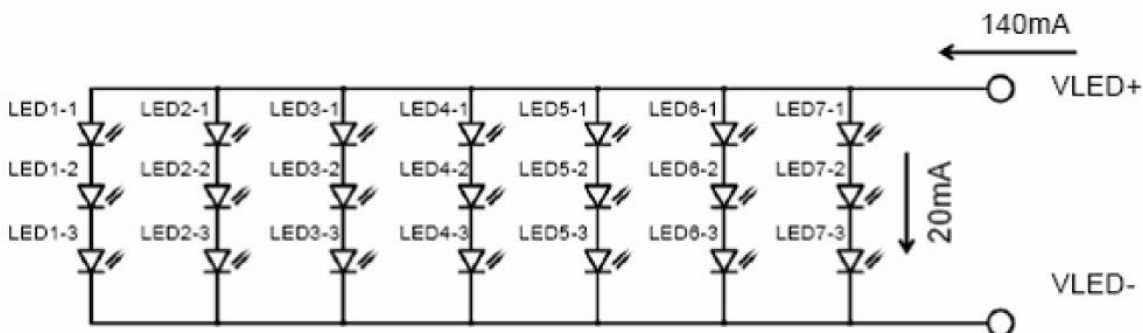

## Electrical Characteristics

Item	Symbol	Condition	Min.	Typ.	Max.	Unit
Operating Temperature Range	T <sub>OP</sub>	Absolute Max	-20	-	+70	°C
Storage Temperature Range	T <sub>ST</sub>	Absolute Max	-30	-	+80	°C
Supply Voltage	V <sub>DD</sub>	-	3.0	3.3	3.6	V
Supply Current	I <sub>DD</sub>	V <sub>DD</sub> = 3.3V	105	210	315	mA
"H" Level input	V <sub>IH</sub>	-	0.8*V <sub>DD</sub>	-	V <sub>DD</sub>	V
"L" Level input	V <sub>IL</sub>	-	GND	-	0.2*V <sub>DD</sub>	V
"H" Level output	V <sub>OH</sub>	-	-	-	-	V
"L" Level output	V <sub>OL</sub>	-	-	-	-	V
Backlight Supply Voltage	V <sub>LED</sub>	-	9.0	9.9	10.5	V
Backlight Supply Current	I <sub>LED</sub>	V <sub>LED</sub> = 9.9V	70	140	210	mA
Backlight Lifetime*	-	I <sub>LED</sub> = 140mA T <sub>OP</sub> = 25°C	-	50,000	-	Hrs.

\*Backlight lifetime is rated as Hours until **half-brightness**, under normal operating conditions.

## Optical Characteristics

Item		Symbol	Condition	Min.	Typ.	Max.	Unit
Optimal Viewing Angles	Top	φY+	CR ≥ 10	-	50	-	°
	Bottom	φY-		-	70	-	°
	Left	θX-		-	70	-	°
	Right	θX+		-	70	-	°
Contrast Ratio		CR	-	150	250	-	-
Luminance		L <sub>V</sub>	I <sub>LED</sub> = 140 mA	-	500	-	cd/m <sup>2</sup>
Response Time	Rise	T <sub>R</sub>	T <sub>OP</sub> = 25°C	-	15	30	ms
	Fall	T <sub>F</sub>		-	35	50	ms

## Controller Information

Built-in SSD1963 Controller.

Please download specification at [http://www.newhavendisplay.com/app\\_notes/SSD1963.pdf](http://www.newhavendisplay.com/app_notes/SSD1963.pdf)

## Touch Panel:

Pin No.	Symbol	External Connection	Function Description
1	Y+	Touch Controller	TOP
2	Y-	Touch Controller	BOTTOM
3	X+	Touch Controller	LEFT
4	X-	Touch Controller	RIGHT

**Recommended Touch panel connector:** 2.54mm pitch Standard Pin Headers

## Touch Panel Characteristics

Item	Min.	Typ.	Max.	Unit
Linearity	-	-	1.5	%
Circuit Resistance – X-Axis	350	-	1000	$\Omega$
Circuit Resistance – Y-Axis	200	-	650	$\Omega$
Insulation Resistance	20	-	-	M $\Omega$
Operating Voltage	-	-	5	V
Chattering	-	-	15	Ms
Transmittance	80	-	-	%
Activation Force	-	-	80	g
Pen Writing Durability	10,000	-	-	Characters
Pitting Durability	1,200,000	-	-	Touches
Surface Hardness	2	-	-	H
Haze	-	7	-	%

## 8080 Mode Interface:

The 8080 mode MPU interface consists of CS#, D/C, RD#, WR#, and DB[7:0]. This interface uses WR# to define a write cycle and RD# to define a read cycle. If the WR# goes LOW when the CS# signal is LOW, the data or command will be latched into the system at the rising edge of WR#. Similarly, the read cycle will start when RD# goes LOW and end at the rising edge of RD#. See the SSD1963 datasheet for detailed timing diagrams.

## Command Instructions:

See the SSD1963 datasheet for the Instruction Table and Command Descriptions.

## Pixel Data Format:

Interface	Cycle	D[7]	D[6]	D[5]	D[4]	D[3]	D[2]	D[1]	D[0]
8 bits	1 <sup>st</sup>	R7	R6	R5	R4	R3	R2	R1	R0
	2 <sup>nd</sup>	G7	G6	G5	G4	G3	G2	G1	G0
	3 <sup>rd</sup>	B7	B6	B5	B4	B3	B2	B1	B0



## Quality Information

Test Item	Content of Test	Test Condition	Note
High Temperature storage	Endurance test applying the high storage temperature for a long time.	+80°C , 200hrs	2
Low Temperature storage	Endurance test applying the low storage temperature for a long time.	-30°C , 200hrs	1,2
High Temperature Operation	Endurance test applying the electric stress (voltage & current) and the high thermal stress for a long time.	+70°C , 200hrs	2
Low Temperature Operation	Endurance test applying the electric stress (voltage & current) and the low thermal stress for a long time.	-20°C , 200hrs	1,2
High Temperature / Humidity Operation	Endurance test applying the electric stress (voltage & current) and the high thermal with high humidity stress for a long time.	+60°C, 90% RH, 96hrs	1,2
Thermal Shock resistance	Endurance test applying the electric stress (voltage & current) during a cycle of low and high thermal stress.	-20°C, 30min -> 25°C, 5min -> 70°C, 30min = 1 cycle For 10 cycles	
Vibration test	Endurance test applying vibration to simulate transportation and use.	10-55Hz, 1.5mm amplitude. 60 sec in each of 3 directions X,Y,Z For 15 minutes	3
Static electricity test	Endurance test applying electric static discharge.	VS=800V, RS=1.5kΩ, CS=100pF One time	

**Note 1:** No condensation to be observed.

**Note 2:** Conducted after 4 hours of storage at 25°C, 0%RH.

**Note 3:** Test performed on product itself, not inside a container.

## Precautions for using LCDs/LCMs

See Precautions at [www.newhavendisplay.com/specs/precautions.pdf](http://www.newhavendisplay.com/specs/precautions.pdf)

## Warranty Information and Terms & Conditions

[http://www.newhavendisplay.com/index.php?main\\_page=terms](http://www.newhavendisplay.com/index.php?main_page=terms)