

THT Common Mode Chokes

PH9455.XXXNL

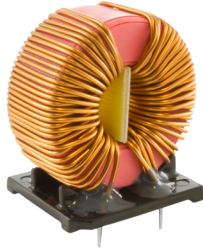

- Dielectric Strength: 1500Vrms
- Inductance Range: 1.00mH (at 22.0A) to 82.0mH (at 3.0A)
- Height: 32.0mm Max
- Footprint: 12.6mm x 10.0mm
- Voltage Rating: 250Vac Max

Electrical Specifications @ 25°C - Operating Temperature -40°C to +125°C

Part Number	Inductance (1-4)=(2-3) (mH +50%/-30%)	Current Rating (1-4)=(2-3) (A)	DCR (1-4)=(2-3) (mΩ Max)	Self Resonant Frequency (1-4)=(2-3) (MHz Min)	Impedance (kOhms Min at SRF)
PH9455.105NL	1.00	22	2.10	15.94	1.5
PH9455.155NL	1.62	19	3.20	10.00	1.8
PH9455.205NL	2.20	16	4.50	8.39	2.6
PH9455.405NL	4.50	12	8.50	4.00	4.4
PH9455.705NL	6.50	9	14.0	1.52	6.4
PH9455.156NL	15.0	6	30.0	0.76	10
PH9455.356NL	35.0	4	80.0	0.33	21
PH9455.826NL	82.0	3	150	0.13	37

Notes:

1. The current rating (Irated) is based upon the temperature rise of the component and represents the rms current which will cause a typical temperature rise of 55°C.

Mechanical

Schematic

PH9455.XXXNL

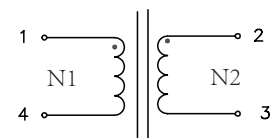
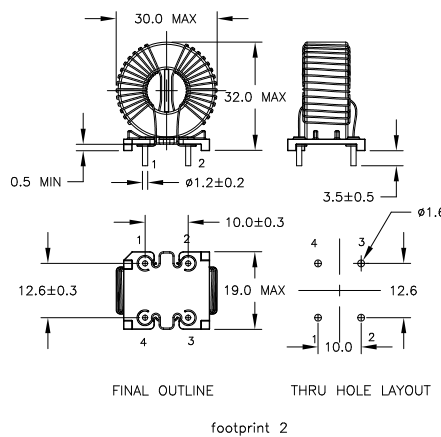
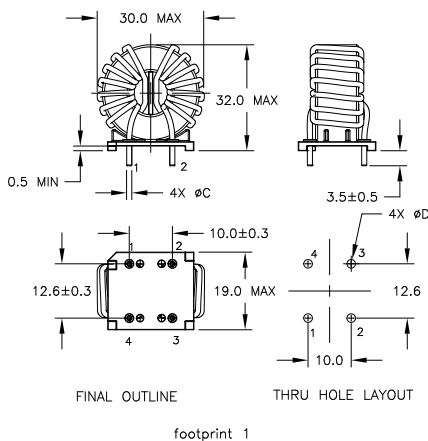

PART NUMBER	C	D	footprint
PH9455.105NL	1.63±0.20	2.10	1
PH9455.155NL	1.45±0.20	1.90	
PH9455.205NL	1.29±0.20	1.70	
PH9455.405NL	1.15±0.20	1.50	
PH9455.705NL	1.02±0.20	1.45	
PH9455.156NL			2
PH9455.356NL			
PH9455.826NL			

Weight (TYP)20grams

Tray45/tray

Dimensions: mm

Unless otherwise specified, all tolerance are ±0.25

USA 858 674 8100

Germany 49 2534 777 100

Singapore 65 6287 8998

Shanghai 86 21 62787060

China 86 755 33966678

Taiwan 886 3 4356768

THT Common Mode Chokes

PH9455.XXXNL

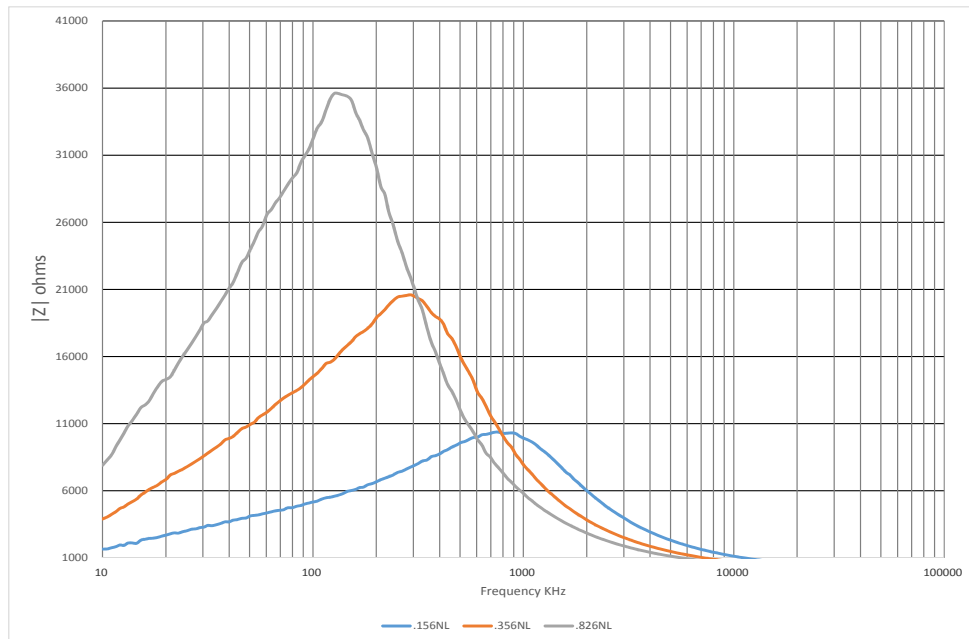
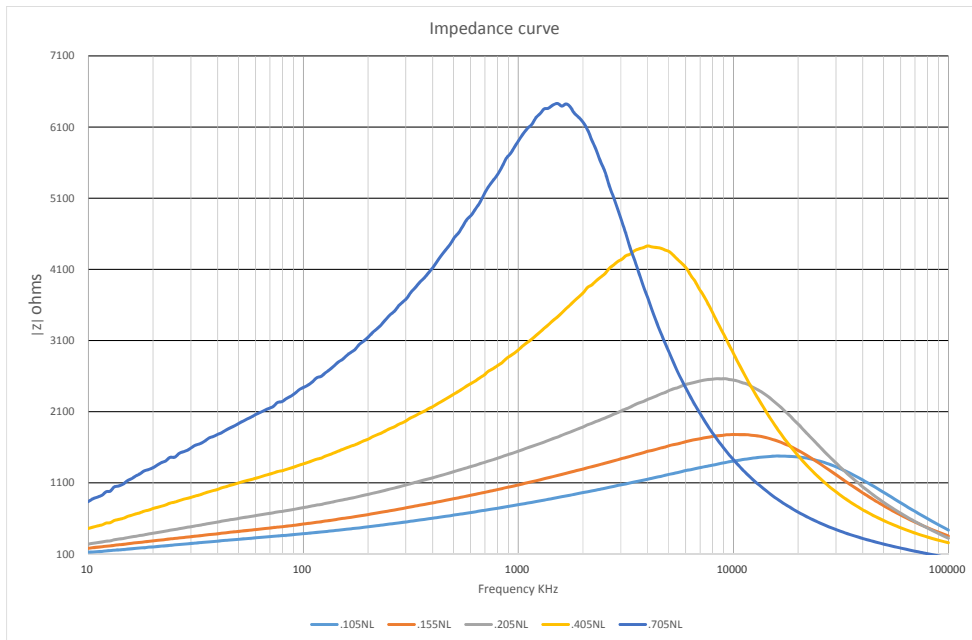

THT Common Mode Chokes

PH9455.XXXNL

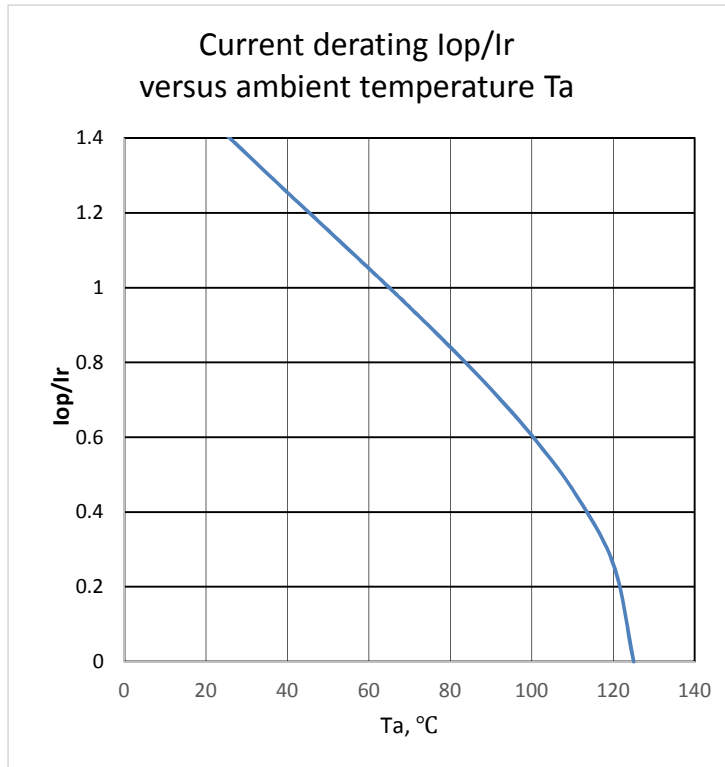

For More Information

Pulse Worldwide Headquarters

15255 Innovation Drive Ste 100
San Diego, CA 92128
U.S.A.

Tel: 858 674 8100
Fax: 858 674 8262

Pulse Europe

Pulse Electronics GmbH
Am Rottland 12
58540 Meinerzhagen
Germany

Tel: 49 2354 777 100
Fax: 49 2354 777 168

Pulse China Headquarters

B402, Shenzhen Academy of
Aerospace Technology Bldg.
10th Kejinan Road
High-Tech Zone
Nanshan District
Shenzhen, PR China 518057

Tel: 86 755 33966678
Fax: 86 755 33966700

Pulse North China

Room 2704/2705
Super Ocean Finance Ctr.
2067 Yan An Road West
Shanghai 200336
China

Tel: 86 21 62787060
Fax: 86 2162786973

Pulse South Asia

135 Joo Seng Road
#03-02
PM Industrial Bldg.
Singapore 368363

Tel: 65 6287 8998
Fax: 65 6287 8998

Pulse North Asia

3F, No. 198
Zhongyuan Road
Zhongli City
Taoyuan County 320
Taiwan R. O. C.

Tel: 886 3 4356768
Fax: 886 3 4356823 (Pulse)
Fax: 886 3 4356820 (FRE)

Performance warranty of products offered on this data sheet is limited to the parameters specified. Data is subject to change without notice. Other brand and product names mentioned herein may be trademarks or registered trademarks of their respective owners. © Copyright, 2017. Pulse Electronics, Inc. All rights reserved.