

The S-35399A03 is a CMOS 2-wire real-time clock IC which operates with the very low current consumption in the wide range of operation voltage. The operation voltage is 1.3 V to 5.5 V so that the S-35399A03 can be used for various power supplies from main supply to backup battery. Due to the 0.34  $\mu$ A current consumption and wide range of power supply voltage at time keeping, The S-35399A03 makes the battery life longer. In the system which operates with a backup battery, the included free registers can be used as the function for user's backup memory. Users always can take back the information in the registers which is stored before power-off the main power supply, after the voltage is restored.

The S-35399A03 has the function to correct advance / delay of the clock data speed, in the wide range, which is caused by the crystal oscillation circuit's frequency deviation. Correcting according to the temperature change by combining this function and a temperature sensor, it is possible to make a high precise clock function which is not affected by the ambient temperature.

Moreover, the S-35399A03 has a 24-bit binary up counter. This counter counts up every 60 seconds from power-on so that users are able to grasp the elapsed time from power-on up to 30 years.

## ■ Features

- Low current consumption: 0.34  $\mu$ A typ. ( $V_{DD} = 3.0$  V,  $T_a = +25^{\circ}$ C)
- Wide range of operating voltage: 1.3 V to 5.5 V
- Built-in clock correction function
- Built-in 24-bit binary up counter
- Built-in free user register
- 2-wire ( $I^2$ C-bus) CPU interface
- Built-in alarm interrupter
- Built-in flag generator during detection of low power voltage or at power-on
- Auto calendar up to the year 2099, automatic leap year calculation function
- Built-in constant voltage circuit
- Built-in 32.768 kHz crystal oscillator (built-in  $C_d$ , external  $C_g$ )
- Lead-free, Sn 100%, halogen-free<sup>\*1</sup>

\*1. Refer to "■ Product Name Structure" for details.

## ■ Applications

- Mobile game device
- Mobile AV device
- Digital still camera
- Digital video camera
- Electronic power meter
- DVD recorder
- TV, VCR
- Mobile phone, PHS

## ■ Package

- 8-Pin SOP (JEDEC)

■ Block Diagram

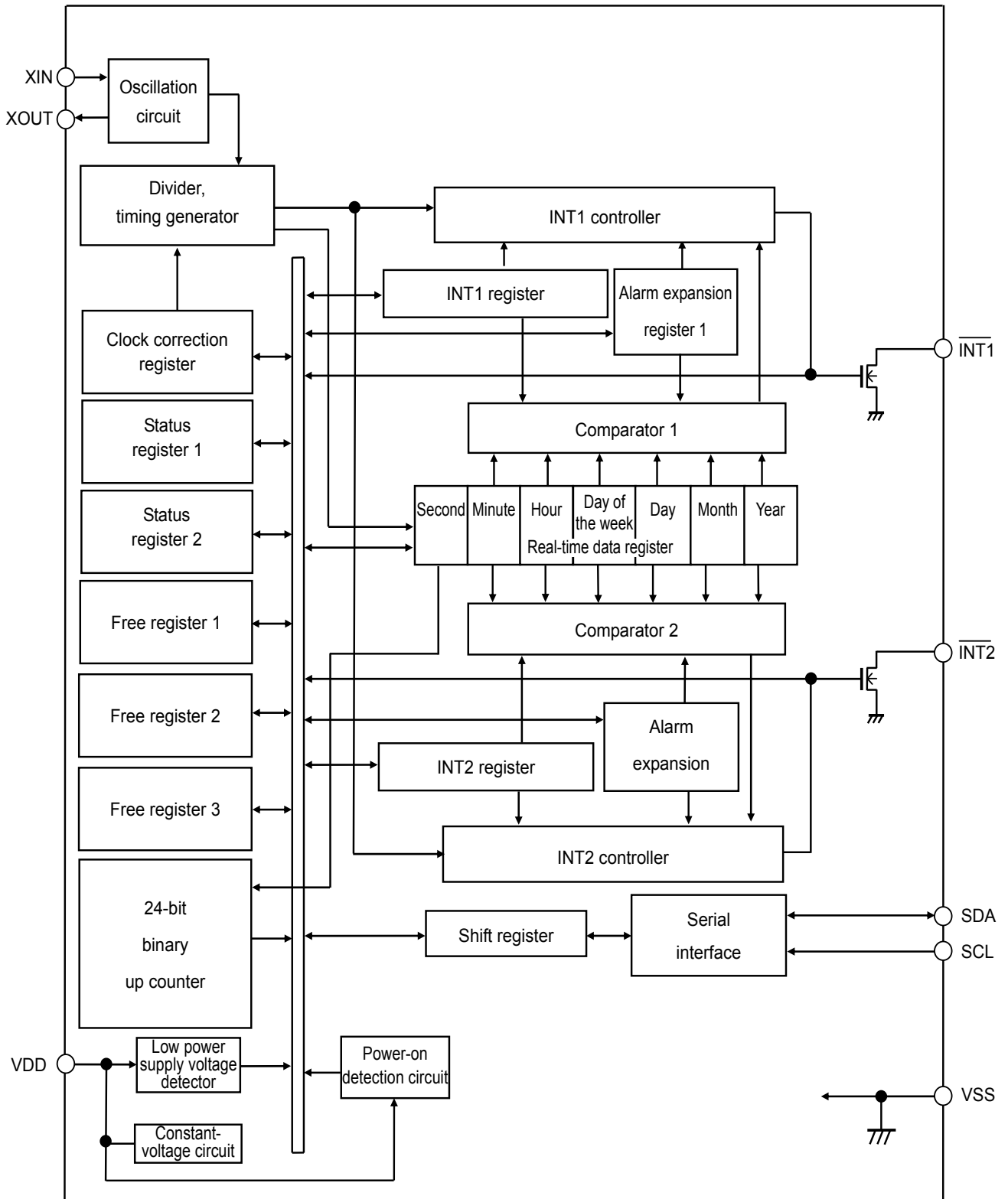
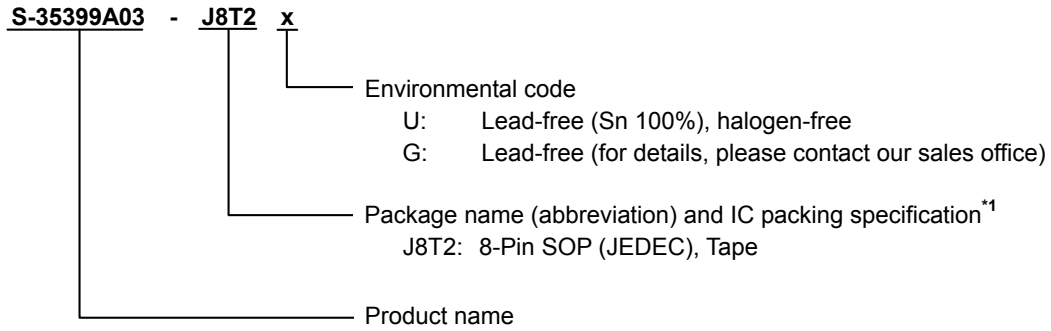


Figure 1

■ **Product Name Structure**

1. **Product name**



\*1. Refer to the tape drawing.

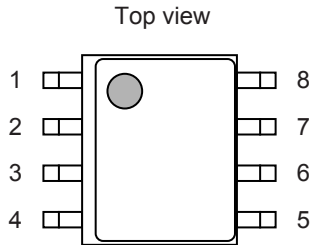
2. **Package**

**Table 1 Package Drawing Codes**

Package Name	Dimension	Tape	Reel	
8-Pin SOP (JEDEC)	Environmental code = G	FJ008-A-P-SD	FJ008-D-C-SD	FJ008-D-R-SD
	Environmental code = U	FJ008-A-P-SD	FJ008-D-C-SD	FJ008-D-R-S1

■ **Pin Configuration**

1. **8-Pin SOP (JEDEC)**



**Figure 2 S-35399A03-J8T2x**

**Table 2 List of Pins**

Pin No	Symbol	Description	I/O	Configuration
1	$\overline{\text{INT1}}$	Output pin for interrupt signal 1	Output	Nch open-drain output (no protective diode at VDD)
2	XOUT	Connection pins for crystal oscillator	-	-
3	XIN			
4	VSS	GND pin	-	-
5	$\overline{\text{INT2}}$	Output pin for interrupt signal 2	Output	Nch open-drain output (no protective diode at VDD)
6	SCL	Input pin for serial clock	Input	CMOS input (no protective diode at VDD)
7	SDA	I/O pin for serial data	Bi-directional	Nch open-drain output (no protective diode at VDD) CMOS input
8	VDD	Pin for positive power supply	-	-

**Remark 1.** x: G or U

**2.** Please select products of environmental code = U for Sn 100%, halogen-free products.

## ■ Pin Functions

### 1. SDA (I/O for serial data) pin

This pin is a data input / output pin of I<sup>2</sup>C-bus interface. This pin inputs / outputs data by synchronizing with a clock pulse from the SCL pin. This pin has CMOS input and Nch open-drain output. Generally in use, pull up this pin to the VDD potential via a resistor, and connect it to any other device having open drain or open collector output with wired-OR connection.

### 2. SCL (input for serial clock) pin

This pin is to input a clock pulse for I<sup>2</sup>C-bus interface. The SDA pin inputs / outputs data by synchronizing with the clock pulse.

### 3. XIN, XOUT (crystal oscillator connect) pins

Connect a crystal oscillator between XIN and XOUT.

### 4. $\overline{\text{INT1}}$ (output for interrupt signal 1) pin

This pin outputs a signal of interrupt, or a clock pulse. By using the status register 2, users can select either of; alarm 1 interrupt, output of user-set frequency, per-minute edge interrupt, minute-periodical interrupt 1, minute-periodical interrupt 2, or 32.768 kHz output. This pin has Nch open-drain output.

### 5. $\overline{\text{INT2}}$ (output for interrupt signal 2) pin

This pin outputs a signal of interrupt, or a clock pulse. By using the status register 2, users can select either of; alarm 2 interrupt, output of user-set frequency, per-minute edge interrupt or minute-periodical interrupt 1. This pin has Nch open-drain output.

### 6. VDD (positive power supply) pin

Connect this VDD pin with a positive power supply. Regarding the values of voltage to be applied, refer to "■ Recommended Operation Conditions".

### 7. VSS pin

Connect this VSS pin to GND.

## ■ Equivalent Circuits of Pins

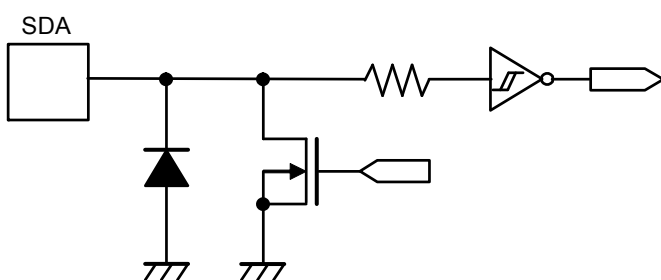


Figure 3 SDA Pin

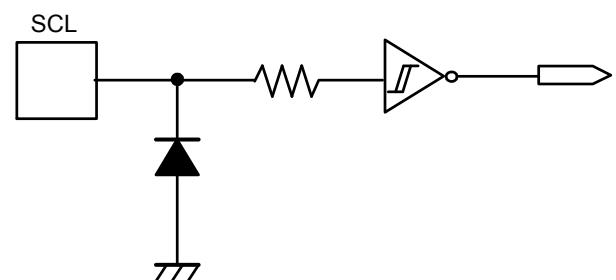


Figure 4 SCL Pin

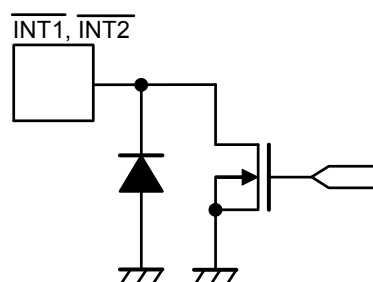


Figure 5  $\overline{\text{INT1}}$  Pin,  $\overline{\text{INT2}}$  Pin

■ **Absolute Maximum Ratings**

**Table 3**

Item	Symbol	Applied Pin	Absolute Maximum Rating	Unit
Power supply voltage	$V_{DD}$	–	$V_{SS} - 0.3$ to $V_{SS} + 6.5$	V
Input voltage	$V_{IN}$	SCL, SDA	$V_{SS} - 0.3$ to $V_{SS} + 6.5$	V
Output voltage	$V_{OUT}$	SDA, $\overline{INT1}$ , INT2	$V_{SS} - 0.3$ to $V_{SS} + 6.5$	V
Operating ambient temperature*1	$T_{opr}$	–	–40 to +85	°C
Storage temperature	$T_{stg}$	–	–55 to +125	°C

\*1. Conditions with no condensation or frost. Condensation or frost causes short-circuiting between pins, resulting in a malfunction.

**Caution** The absolute maximum ratings are rated values exceeding which the product could suffer physical damage. These values must therefore not be exceeded under any conditions.

■ **Recommended Operation Conditions**

**Table 4**

( $V_{SS} = 0$  V)

Item	Symbol	Condition	Min.	Typ.	Max.	Unit
Power supply voltage*1	$V_{DD}$	$T_a = -40^\circ\text{C}$ to $+85^\circ\text{C}$	1.3	3.0	5.5	V
Time keeping power supply voltage*2	$V_{DDT}$	$T_a = -40^\circ\text{C}$ to $+85^\circ\text{C}$	$V_{DET} - 0.15$	–	5.5	V
Crystal oscillator $C_L$ value	$C_L$	–	–	6	7	pF

\*1. The power supply voltage that allows communication under the conditions shown in **Table 9** of "■ **AC Electrical Characteristics**".

\*2. The power supply voltage that allows time keeping. For the relationship with  $V_{DET}$  (low power supply voltage detection voltage), refer to "■ **Characteristics (Typical Data)**".

■ **Oscillation Characteristics**

**Table 5**

( $T_a = +25^\circ\text{C}$ ,  $V_{DD} = 3.0$  V,  $V_{SS} = 0$  V, SSP-T7-FL crystal oscillator ( $C_L = 6$  pF, 32.768 kHz) manufactured by Seiko Instruments Inc.)

Item	Symbol	Condition	Min.	Typ.	Max.	Unit
Oscillation start voltage	$V_{STA}$	Within 10 seconds	1.1	–	5.5	V
Oscillation start time	$t_{STA}$	–	–	–	1	s
IC-to-IC frequency deviation*1	$\delta IC$	–	–10	–	+10	ppm
Frequency voltage deviation	$\delta V$	$V_{DD} = 1.3$ V to 5.5 V	–3	–	+3	ppm/V
External capacitance	$C_g$	Applied to XIN pin	–	–	9.1	pF
Internal oscillation capacitance	$C_d$	Applied to XOUT pin	–	8	–	pF

\*1. Reference value

## ■ DC Electrical Characteristics

**Table 6 DC Characteristics (V<sub>DD</sub> = 3.0 V)**

(Ta = -40 °C to +85°C, V<sub>SS</sub> = 0 V, SSP-T7-FL crystal oscillator (C<sub>L</sub> = 6 pF, 32.768 kHz, C<sub>g</sub> = 9.1 pF) manufactured by Seiko Instruments Inc.)

Item	Symbol	Applied Pin	Condition	Min.	Typ.	Max.	Unit
Current consumption 1	I <sub>DD1</sub>	–	Out of communication	–	0.34	0.97	μA
Current consumption 2	I <sub>DD2</sub>	–	Out of communication (when 32.768 kHz is output from $\overline{\text{INT1}}$ pin)	–	0.60	1.47	μA
Current consumption 3	I <sub>DD3</sub>	–	During communication (SCL = 100 kHz)	–	9	14	μA
Input current leakage 1	I <sub>IZH</sub>	SCL, SDA	V <sub>IN</sub> = V <sub>DD</sub>	-0.5	–	0.5	μA
Input current leakage 2	I <sub>IZL</sub>	SCL, SDA	V <sub>IN</sub> = V <sub>SS</sub>	-0.5	–	0.5	μA
Output current leakage 1	I <sub>OZH</sub>	SDA, $\overline{\text{INT1}}$ , $\overline{\text{INT2}}$	V <sub>OUT</sub> = V <sub>DD</sub>	-0.5	–	0.5	μA
Output current leakage 2	I <sub>OZL</sub>	SDA, $\overline{\text{INT1}}$ , $\overline{\text{INT2}}$	V <sub>OUT</sub> = V <sub>SS</sub>	-0.5	–	0.5	μA
Input voltage 1	V <sub>IH</sub>	SCL, SDA	–	0.8 × V <sub>DD</sub>	–	V <sub>SS</sub> + 5.5	V
Input voltage 2	V <sub>IL</sub>	SCL, SDA	–	V <sub>SS</sub> - 0.3	–	0.2 × V <sub>DD</sub>	V
Output current 1	I <sub>OL1</sub>	$\overline{\text{INT1}}$ , $\overline{\text{INT2}}$	V <sub>OUT</sub> = 0.4 V	3	5	–	mA
Output current 2	I <sub>OL2</sub>	SDA	V <sub>OUT</sub> = 0.4 V	5	10	–	mA
Power supply voltage detection voltage	V <sub>DET</sub>	–	–	0.65	1	1.35	V

**Table 7 DC Characteristics (V<sub>DD</sub> = 5.0 V)**

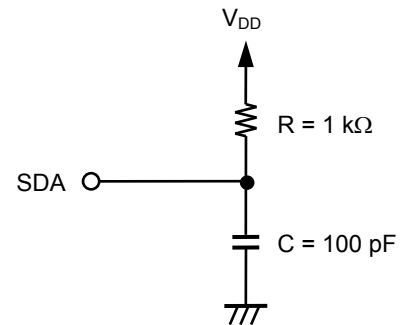
(Ta = -40°C to +85°C, V<sub>SS</sub> = 0 V, SSP-T7-FL crystal oscillator (C<sub>L</sub> = 6 pF, 32.768 kHz, C<sub>g</sub> = 9.1 pF) manufactured by Seiko Instruments Inc.)

Item	Symbol	Applied Pin	Condition	Min.	Typ.	Max.	Unit
Current consumption 1	I <sub>DD1</sub>	–	Out of communication	–	0.36	1.18	μA
Current consumption 2	I <sub>DD2</sub>	–	Out of communication (when 32.768 kHz is output from $\overline{\text{INT1}}$ pin)	–	0.82	2.17	μA
Current consumption 3	I <sub>DD3</sub>	–	During communication (SCL = 100 kHz)	–	20	30	μA
Input current leakage 1	I <sub>IZH</sub>	SCL, SDA	V <sub>IN</sub> = V <sub>DD</sub>	-0.5	–	0.5	μA
Input current leakage 2	I <sub>IZL</sub>	SCL, SDA	V <sub>IN</sub> = V <sub>SS</sub>	-0.5	–	0.5	μA
Output current leakage 1	I <sub>OZH</sub>	SDA, $\overline{\text{INT1}}$ , $\overline{\text{INT2}}$	V <sub>OUT</sub> = V <sub>DD</sub>	-0.5	–	0.5	μA
Output current leakage 2	I <sub>OZL</sub>	SDA, $\overline{\text{INT1}}$ , $\overline{\text{INT2}}$	V <sub>OUT</sub> = V <sub>SS</sub>	-0.5	–	0.5	μA
Input voltage 1	V <sub>IH</sub>	SCL, SDA	–	0.8 × V <sub>DD</sub>	–	V <sub>SS</sub> + 5.5	V
Input voltage 2	V <sub>IL</sub>	SCL, SDA	–	V <sub>SS</sub> - 0.3	–	0.2 × V <sub>DD</sub>	V
Output current 1	I <sub>OL1</sub>	$\overline{\text{INT1}}$ , $\overline{\text{INT2}}$	V <sub>OUT</sub> = 0.4 V	5	8	–	mA
Output current 2	I <sub>OL2</sub>	SDA	V <sub>OUT</sub> = 0.4 V	6	13	–	mA
Power supply voltage detection voltage	V <sub>DET</sub>	–	–	0.65	1	1.35	V

■ AC Electrical Characteristics

Table 8 Measurement Conditions

Input pulse voltage	$V_{IH} = 0.8 \times V_{DD}, V_{IL} = 0.2 \times V_{DD}$
Input pulse rise / fall time	20 ns
Output determination voltage	$V_{OH} = 0.5 \times V_{DD}, V_{OL} = 0.5 \times V_{DD}$
Output load	100 pF + pull-up resistor 1 kΩ



**Remark** The power supplies of the IC and load have the same electrical potential.

Figure 6 Output Load Circuit

Table 9 AC Electrical Characteristics

( $T_a = -40^\circ\text{C}$  to  $+85^\circ\text{C}$ )

Item	Symbol	$V_{DD}^{*2} \geq 1.3\text{ V}$			$V_{DD}^{*2} \geq 3.0\text{ V}$			Unit
		Min.	Typ.	Max.	Min.	Typ.	Max.	
SCL clock frequency	$f_{SCL}$	0	–	100	0	–	400	kHz
SCL clock low time	$t_{LOW}$	4.7	–	–	1.3	–	–	$\mu\text{s}$
SCL clock high time	$t_{HIGH}$	4	–	–	0.6	–	–	$\mu\text{s}$
SDA output delay time <sup>*1</sup>	$t_{PD}$	–	–	3.5	–	–	0.9	$\mu\text{s}$
Start condition setup time	$t_{SU.STA}$	4.7	–	–	0.6	–	–	$\mu\text{s}$
Start condition hold time	$t_{HD.STA}$	4	–	–	0.6	–	–	$\mu\text{s}$
Data input setup time	$t_{SU.DAT}$	250	–	–	100	–	–	ns
Data input hold time	$t_{HD.DAT}$	0	–	–	0	–	–	$\mu\text{s}$
Stop condition setup time	$t_{SU.STO}$	4.7	–	–	0.6	–	–	$\mu\text{s}$
SCL, SDA rise time	$t_R$	–	–	1	–	–	0.3	$\mu\text{s}$
SCL, SDA fall time	$t_F$	–	–	0.3	–	–	0.3	$\mu\text{s}$
Bus release time	$t_{BUF}$	4.7	–	–	1.3	–	–	$\mu\text{s}$
Noise suppression time	$t_i$	–	–	100	–	–	50	ns

\*1. Since the output format of the SDA pin is Nch open-drain output, SDA output delay time is determined by the values of the load resistance ( $R_L$ ) and load capacity ( $C_L$ ) outside the IC. Therefore, use this value only as a reference value.

\*2. Regarding the power supply voltage, refer to "■ Recommended Operation Conditions".

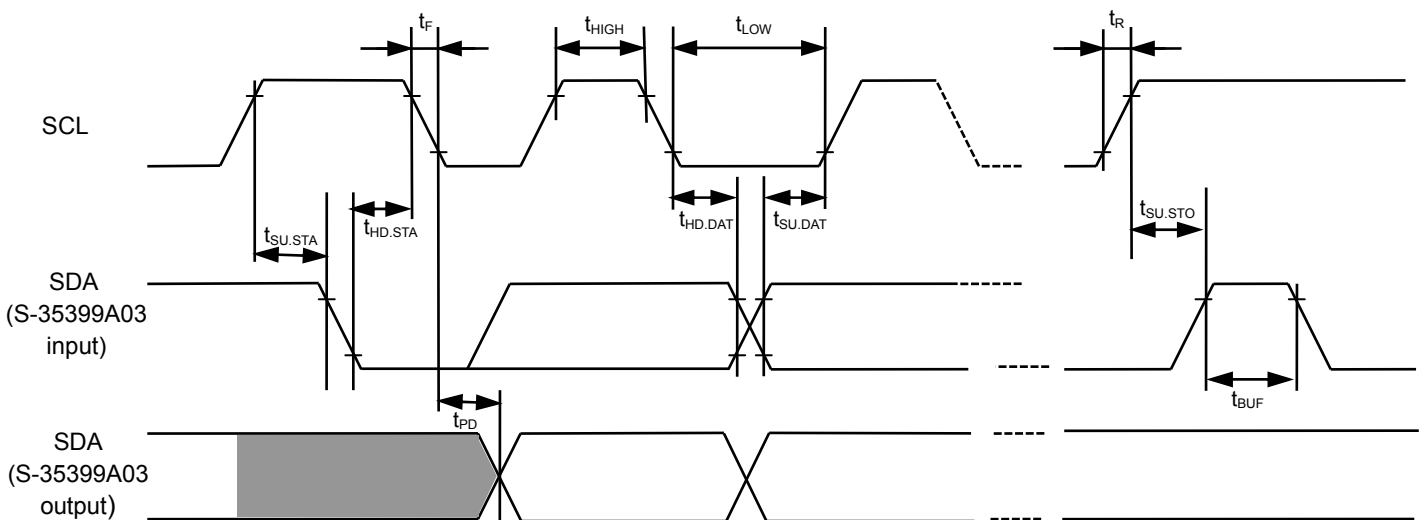


Figure 7 Bus Timing

■ Configuration of Data Communication

1. Data Communication

For data communication, the master device in the system generates a start condition for the S-35399A03. Next, the master device transmits 4-bit device code "0110" or "0111", and 3-bit command and 1-bit read / write command to the SDA line. After that, output or input is performed from B7 of data. If data I/O has been completed, finish communication by inputting a stop condition to the S-35399A03. The master device generates an acknowledgment signal for every 1-byte. Regarding details, refer to "■ Serial Interface". Device code "0110" is compatible with the ABLIC Inc. S-35390A/392A as software. Regarding details, refer to "2. Configuration of command".

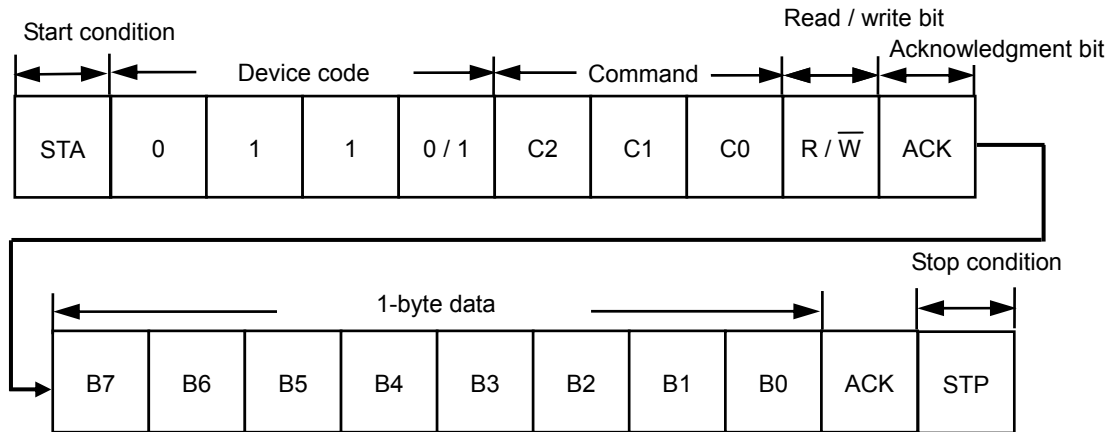


Figure 8 Data Communication

**2. Configuration of command**

13 types of command are available for the S-35399A03. The S-35399A03 reads / writes the various registers by inputting these codes and commands. The S-35399A03 does not perform any operation with any codes and commands other than those below.

**Table 10 List of Commands**

Code	Command			Data								
	C2	C1	C0	Description	B7	B6	B5	B4	B3	B2	B1	B0
0110	0	0	0	Status register 1 access	RESET*1	$\overline{12}/24$	SC0*2	SC1*2	INT1*3	INT2*3	BLD*4	POC*4
	0	0	1	Status register 2 access	INT1FE	INT1ME	INT1AE	32kE	INT2FE	INT2ME	INT2AE	TEST*5
	0	1	0	Real-time data 1 access (year data to)	Y1	Y2	Y4	Y8	Y10	Y20	Y40	Y80
					M1	M2	M4	M8	M10	-*6	-*6	-*6
					D1	D2	D4	D8	D10	D20	-*6	-*6
					W1	W2	W4	-*6	-*6	-*6	-*6	-*6
					H1	H2	H4	H8	H10	H20	AM/PM	-*6
					m1	m2	m4	m8	m10	m20	m40	-*6
	s1	s2	s4	s8	s10	s20	s40	-*6				
	0	1	1	Real-time data 2 access (hour data to)	H1	H2	H4	H8	H10	H20	AM/PM	-*6
					m1	m2	m4	m8	m10	m20	m40	-*6
	1	0	0	INT1 register access (alarm time 1: week / hour / minute) (INT1AE = 1, INT1ME = 0, INT1FE = 0)	W1	W2	W4	-*6	-*6	-*6	-*6	A1WE
					H1	H2	H4	H8	H10	H20	AM/PM	A1HE
1 Hz				2 Hz	4 Hz	8 Hz	16 Hz	SC2*2	SC3*2	SC4*2		
											INT1 register access (output of user-set frequency) (INT1ME = 0, INT1FE = 1)	
1	0	1	INT2 register access (alarm time 2: week / hour / minute) (INT2AE = 1, INT2ME = 0, INT2FE = 0)	W1	W2	W4	-*6	-*6	-*6	-*6	A2WE	
				H1	H2	H4	H8	H10	H20	AM/PM	A2HE	
1 Hz	2 Hz	4 Hz	8 Hz	16 Hz	SC5*2	SC6*2	SC7*2					
								INT2 register access (output of user-set frequency) (INT2ME = 0, INT2FE = 1)				
1	1	0	Clock correction register access	V0	V1	V2	V3	V4	V5	V6	V7	
1	1	1	Free register 1 access	F10	F11	F12	F13	F14	F15	F16	F17	
0111	0	0	Up counter access*7	C64k	C128k	C256k	C512k	C1M	C2M	C4M	C8M	
				C256	C512	C1k	C2k	C4k	C8k	C16k	C32k	
				C1	C2	C4	C8	C16	C32	C64	C128	
	0	0	1	Free register 2 access	F20	F21	F22	F23	F24	F25	F26	F27
	0	1	0	Free register 3 access	F30	F31	F32	F33	F34	F35	F36	F37
	1	0	0	Alarm expansion register 1 access (alarm time 1: year / month / day)	Y1	Y2	Y4	Y8	Y10	Y20	Y40	Y80
M1					M2	M4	M8	M10	-*6	A1YE	A1ME	
D1	D2	D4	D8	D10	D20	-*6	A1DE					
1	0	1	Alarm expansion register 2 access (alarm time 2: year / month / day)	Y1	Y2	Y4	Y8	Y10	Y20	Y40	Y80	
				M1	M2	M4	M8	M10	-*6	A2YE	A2ME	
D1	D2	D4	D8	D10	D20	-*6	A2DE					

- \*1. Write-only flag. The S-35399A03 initializes by writing "1" in this register.
- \*2. Scratch bit. This is a register which is available for read / write operations and can be used by users freely.
- \*3. Read-only flag. Valid only when using the alarm function. When the alarm time matches, this flag is set to "1", and it is cleared to "0" when reading.
- \*4. Read-only flag. "POC" is set to "1" when power is applied. It is cleared to "0" when reading. Regarding "BLD", refer to "■ Low Power Supply Voltage Detection Circuit".
- \*5. Test bit for ABLIC Inc. Be sure to set to "0" in use.
- \*6. No effect when writing. It is "0" when reading.
- \*7. The up counter is a read-only register.

■ Configuration of Registers

1. Real-time data register

The real-time data register is a 7-byte register that stores the data of year, month, day, day of the week, hour, minute, and second in the BCD code. To write / read real-time data 1 access, transmit / receive the data of year in B7, month, day, day of the week, hour, minute, second in B0, in 7-byte. When you skip the procedure to access the data of year, month, day, day of the week, read / write real-time data 2 access. In this case, transmit / receive the data of hour in B7, minute, second in B0, in 3-byte.

The S-35399A03 transfers a set of data of time to the real-time data register when it recognizes a reading instruction. Therefore, the S-35399A03 keeps precise time even if time-carry occurs during the reading operation of the real-time data register.

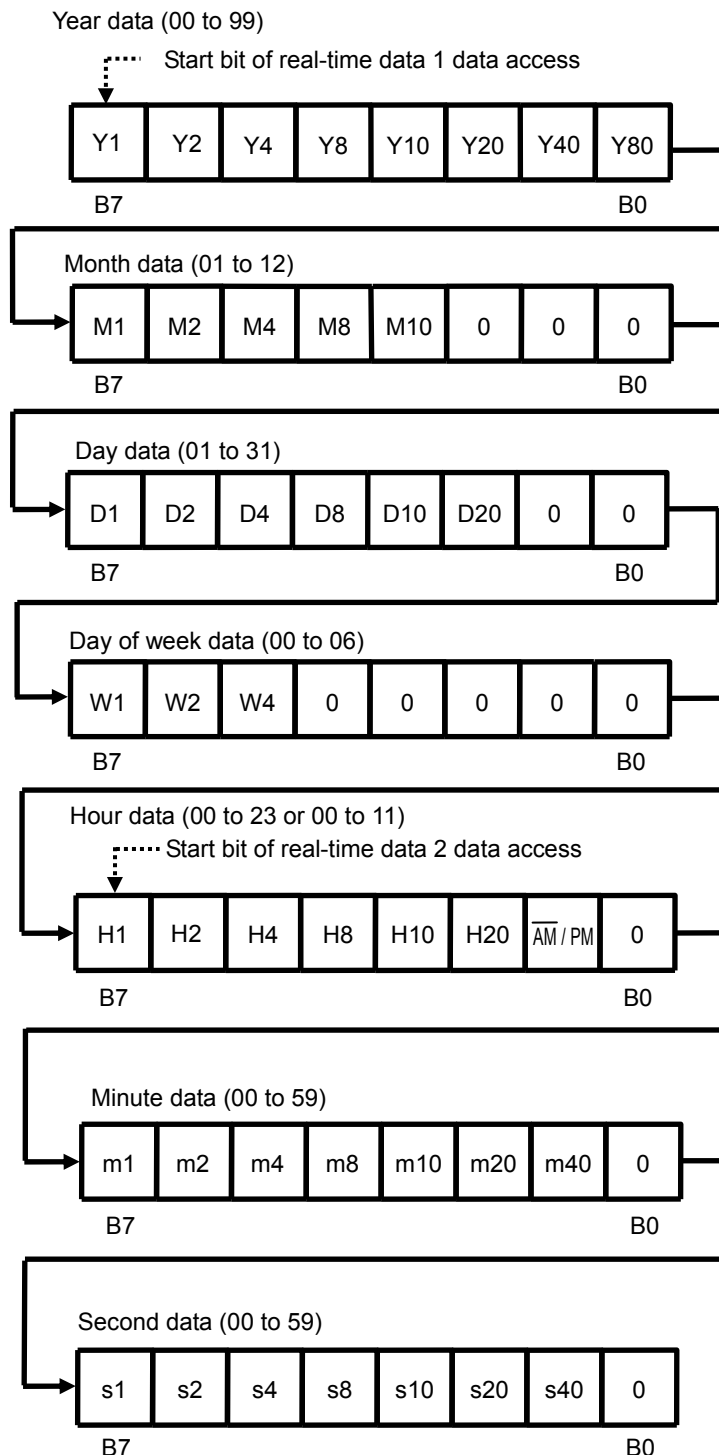


Figure 9 Real-Time Data Register

**Year data (00 to 99): Y1, Y2, Y4, Y8, Y10, Y20, Y40, Y80**

Sets the lower two digits in the Western calendar year (00 to 99) and links together with the auto calendar function until 2099.

Example: 2053 (Y1, Y2, Y4, Y8, Y10, Y20, Y40, Y80) = (1, 1, 0, 0, 1, 0, 1, 0)

**Month data (01 to 12): M1, M2, M4, M8, M10**

Example: December (M1, M2, M4, M8, M10, 0, 0, 0) = (0, 1, 0, 0, 1, 0, 0, 0)

**Day data (01 to 31): D1, D2, D4, D8, D10, D20**

The count value is automatically changed by the auto calendar function.

1 to 31: Jan., Mar., May, July, Aug., Oct., Dec., 1 to 30: April, June, Sep., Nov.

1 to 29: Feb. (leap year), 1 to 28: Feb. (non-leap year)

Example: 29 (D1, D2, D4, D8, D10, D20, 0, 0) = (1, 0, 0, 1, 0, 1, 0, 0)

**Day of the week data (00 to 06): W1, W2, W4**

A septenary up counter. Day of the week is counted in the order of 00, 01, 02, ..., 06, and 00. Set up day of the week and the count value.

**Hour data (00 to 23 or 00 to 11): H1, H2, H4, H8, H10, H20,  $\overline{\text{AM}} / \text{PM}$**

In 12-hour mode, write 0; AM, 1; PM in the  $\overline{\text{AM}} / \text{PM}$  bit. In 24-hour mode, users can write either 0 or 1. 0 is read when the hour data is from 00 to 11, and 1 is read when from 12 to 23.

Example (12-hour mode): 11 p.m. (H1, H2, H4, H8, H10, H20,  $\overline{\text{AM}} / \text{PM}$ , 0) = (1, 0, 0, 0, 1, 0, 1, 0)

Example (24-hour mode): 22 (H1, H2, H4, H8, H10, H20,  $\overline{\text{AM}} / \text{PM}$ , 0) = (0, 1, 0, 0, 0, 1, 1, 0)

**Minute data (00 to 59): m1, m2, m4, m8, m10, m20, m40**

Example: 32 minutes (m1, m2, m4, m8, m10, m20, m40, 0) = (0, 1, 0, 0, 1, 1, 0, 0)

Example: 55 minutes (m1, m2, m4, m8, m10, m20, m40, 0) = (1, 0, 1, 0, 1, 0, 1, 0)

**Second data (00 to 59): s1, s2, s4, s8, s10, s20, s40**

Example: 19 seconds (s1, s2, s4, s8, s10, s20, s40, 0) = (1, 0, 0, 1, 1, 0, 0, 0)

## 2. Status register 1

Status register 1 is a 1-byte register that is used to display and set various modes. The bit configuration is shown below.

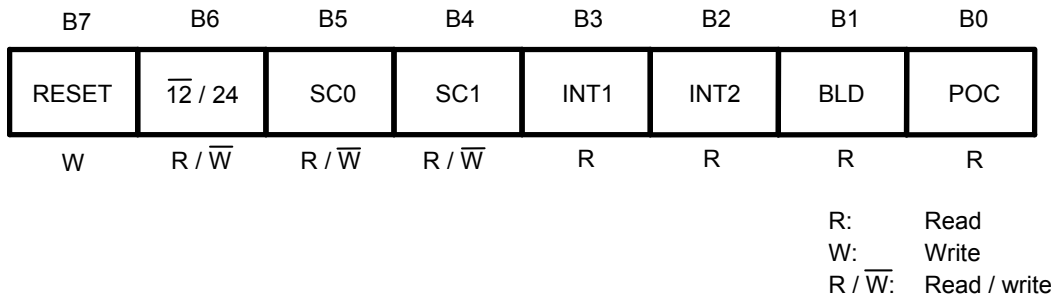


Figure 10 Status Register 1

### B0: POC

This flag is used to confirm whether the power is on. The power-on detection circuit operates at power-on and B0 is set to "1". This flag is read-only. Once it is read, it is automatically set to "0". When this flag is "1", be sure to initialize. Regarding the operation after power-on, refer to "■ Power-on Detection Circuit and Register Status".

### B1: BLD

This flag is set to "1" when the power supply voltage decreases to the level of detection voltage ( $V_{DET}$ ) or less. Users can detect a drop in the power supply voltage. Once this flag is set to "1", it is not set to "0" again even if the power supply increases to the level of detection voltage ( $V_{DET}$ ) or more. This flag is read-only. When this flag is "1", be sure to initialize. Regarding the operation of the power supply voltage detection circuit, refer to "■ Low Power Supply Voltage Detection Circuit".

### B2, B3: INT2, INT1

This flag indicates the time set by alarm and when the time has reached it. This flag is set to "1" when the time that users set by using the alarm interrupt function has come. The INT1 flag at alarm 1 interrupt mode and the INT2 flag at alarm 2 interrupt mode are set to "1". Set "0" in INT1AE (B5 in the status register 2) or in INT2AE (B1 in the status register 2) after reading "1" in the INT1 flag or in the INT2 flag. This flag is read-only. Once this flag is read, it is set to "0" automatically.

### B4, B5: SC1, SC0

These flags configure a 2-bit SRAM type register that can be freely set by users.

### B6: $\overline{12}/24$

This flag is used to set 12-hour or 24-hour mode. Set the flag ahead of write operation of the real-time data register in case of 24-hour mode.

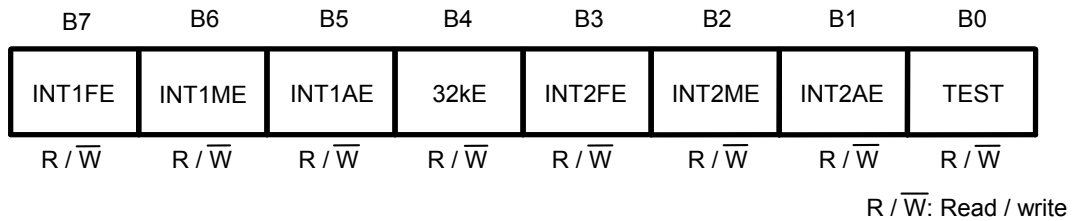
- 0: 12-hour mode
- 1: 24-hour mode

### B7: RESET

The internal IC is initialized by setting this bit to "1". This bit is Write-only. It is always "0" when reading. When applying the power supply voltage to the IC, be sure to write "1" to this bit to initialize the circuit. Regarding each status of registers after initialization, refer to "■ Register Status After Initialization".

**3. Status register 2**

Status register 2 is a 1-byte register that is used to display and set various modes. The bit configuration is shown below.



**Figure 11 Status Register 2**

**B0: TEST**

This is a test flag for ABLIC Inc. Be sure to set this flag to "0" in use. If this flag is set to "1", be sure to initialize to set "0".

**B1: INT2AE, B2: INT2ME, B3: INT2FE**

These bits are used to select the output mode for the  $\overline{INT2}$  pin. **Table 11** shows how to select the mode. To use an alarm 2 interrupt, set alarm interrupt mode, then access the INT2 register and the alarm expansion register 2.

**Table 11 Output Modes for  $\overline{INT2}$  Pin**

INT2AE	INT2ME	INT2FE	$\overline{INT2}$ Pin Output Mode
0	0	0	No interrupt
$\bar{*}$ 1	0	1	Output of user-set frequency
$\bar{*}$ 1	1	0	Per-minute edge interrupt
$\bar{*}$ 1	1	1	Minute-periodical interrupt 1 (50% duty)
1	0	0	Alarm 2 interrupt

\*1. Don't care (both of 0 and 1 are acceptable).

**B4: 32kE, B5: INT1AE, B6: INT1ME, B7: INT1FE**

These bits are used to select the output mode for the  $\overline{INT1}$  pin. **Table 12** shows how to select the mode. To use an alarm 1 interrupt, set alarm interrupt mode, then access the INT1 register and the alarm expansion register 1.

**Table 12 Output Modes for  $\overline{INT1}$  Pin**

32kE	INT1AE	INT1ME	INT1FE	$\overline{INT1}$ Pin Output Mode
0	0	0	0	No interrupt
0	$\bar{*}$ 1	0	1	Output of user-set frequency
0	$\bar{*}$ 1	1	0	Per-minute edge interrupt
0	0	1	1	Minute-periodical interrupt 1 (50% duty)
0	1	0	0	Alarm 1 interrupt
0	1	1	1	Minute-periodical interrupt 2
1	$\bar{*}$ 1	$\bar{*}$ 1	$\bar{*}$ 1	32.768 kHz output

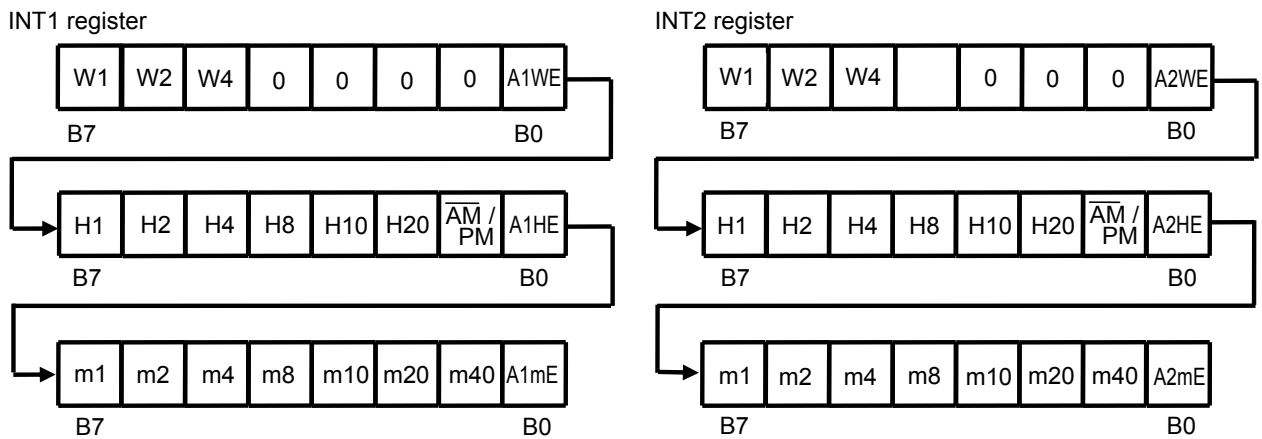
\*1. Don't care (both of 0 and 1 are acceptable).

**4. INT1 register and INT2 register**

The INT1 and INT2 registers are to set up the output of user-set frequency, or to set up alarm interrupt. Users are able to switch the output mode by using the status register 2. If selecting to use the output mode for alarm interrupt by status register 2; this register works as the alarm-time data register. If selecting the output of user-set frequency by status register 2; this register works as the data register to set the frequency for clock output. From each INT1 and INT2 pin, a clock pulse and alarm interrupt are output.

**4.1 Alarm interrupt**

Users can set the alarm time (the data of day of the week, hour, minute) by using the INT1 and INT2 registers which are 3-byte data registers. The configuration of register is as well as the data register of day of the week, hour, minute, in the real-time data register; is expressed by the BCD code. Do not set a nonexistent day. Users are necessary to set up the alarm-time data according to the 12 / 24 hour mode that they set by using the status register 1.



**Figure 12 INT1 Register and INT2 Register (Alarm Time-Data)**

The INT1 register has A1WE, A1HE, A1mE at B0 in each byte. It is possible to make data valid; the data of day of the week, hour, minute which are in the corresponding byte; by setting these bits to "1". This is as well in A2WE, A2HE, A2mE in the INT2 register. Regarding set-up of year, month, day, refer to "8. Alarm expansion register 1 and alarm expansion register 2".

Setting example: alarm time "7:00 pm" in the INT1 register

**(1) 12-hour mode (status register 1 B6 = 0)**

Set up 7:00 PM

Data written to INT1 register

Day of week	_*1	_*1	_*1	_*1	_*1	_*1	_*1	0	
Hour	1	1	1	0	0	0	1	1	
Minute	0	0	0	0	0	0	0	1	
	B7							B0	

\*1. Don't care (both of 0 and 1 are acceptable).

**(2) 24-hour mode (status register 1 B6 = 1)**

Set up 19:00 PM

Data written to INT1 register

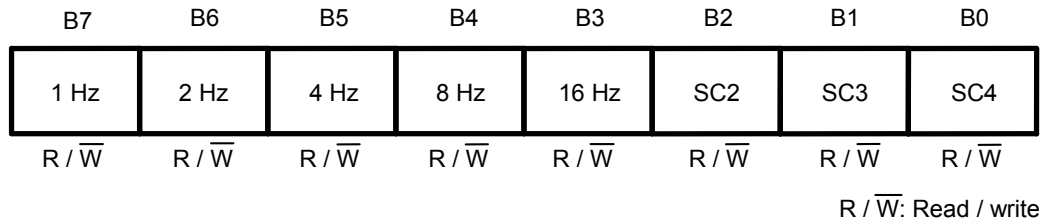
Day of week	_*1	_*1	_*1	_*1	_*1	_*1	_*1	0	
Hour	1	0	0	1	1	0	1 <sup>*2</sup>	1	
Minute	0	0	0	0	0	0	0	1	
	B7							B0	

\*1. Don't care (both of 0 and 1 are acceptable).

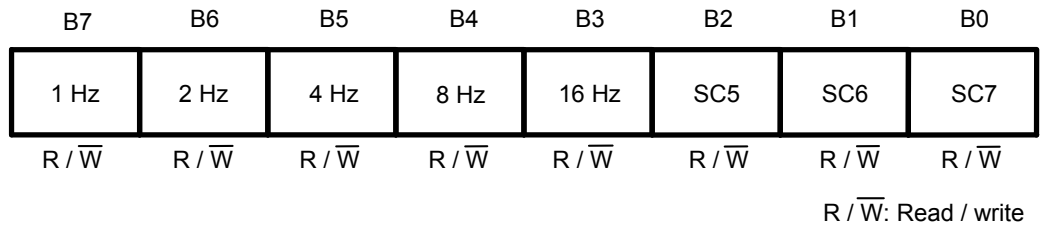
\*2. Set up the AM / PM flag along with the time setting.

**4.2 Output of user-set frequency**

The INT1 and INT2 registers are 1-byte data registers to set up the output frequency. Setting each bit B7 to B3 in the register to "1", the frequency which corresponds to the bit is output in the AND-form. SC2 to SC4 in the INT1 register, and SC5 to SC7 in the INT2 register are 3-bit SRAM type registers that can be freely set by users.

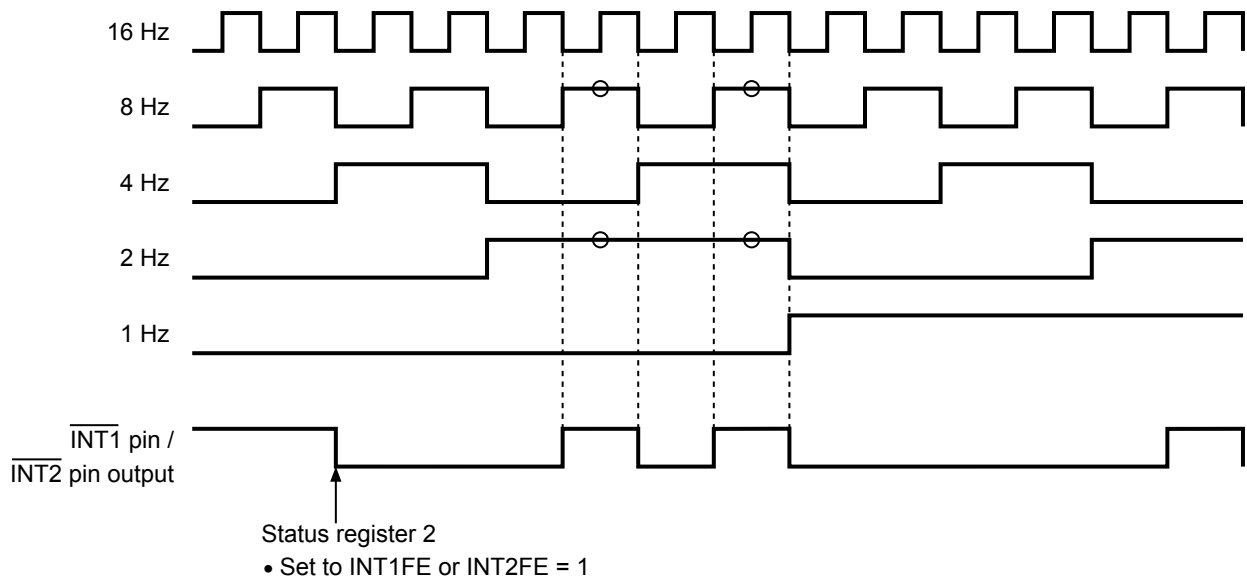


**Figure 13 INT1 Register (Data Register for Output Frequency)**



**Figure 14 INT2 Register (Data Register for Output Frequency)**

**Example:** B7 to B3 = 50h



**Figure 15 Example of Output from INT1 Register (Data Register for Output Frequency)**

1 Hz clock output is synchronized with second-counter of the S-35399A03.

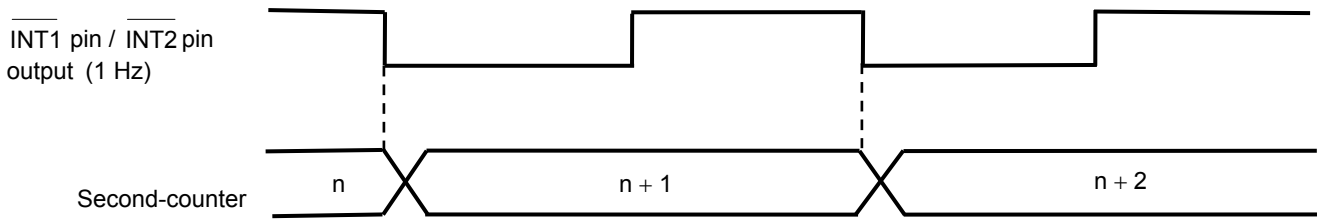


Figure 16 1 Hz Clock Output and Second-counter

5. Clock correction register

The clock correction register is a 1-byte register that is used to correct advance / delay of the clock. When not using this function, set this register to "00h". Regarding the register values, refer to "■ Function of Clock Correction".

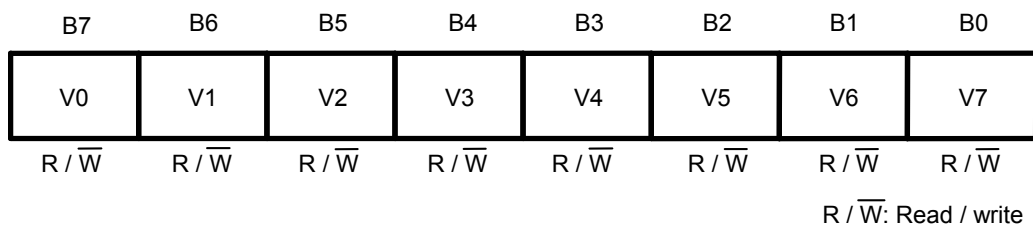


Figure 17 Clock Correction Register

6. Free registers 1 to 3

These free registers are 1-byte SRAM type registers that can be set freely by users.

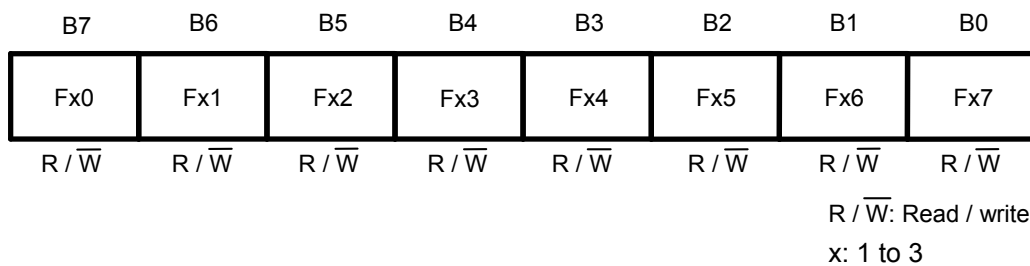


Figure 18 Free Register

7. Up counter

The up counter is a 24-bit read-only register. It starts binary counting from "000000 h" from power-on and continues counting as long as power is being applied. It continues counting when initialization, instead of returning to "000000 h". At power-on, registers are cleared by the power-on detection circuit so that the up counter is cleared to "000000 h". If the power-on detection circuit does not operate successfully, the counter may start from the indefinite status. For successful operation of the power-on detection circuit, refer to "■ Power-on Detection Circuit and Register Status". Regarding the operation timing of the up counter, refer to "■ Up-Count Operation".

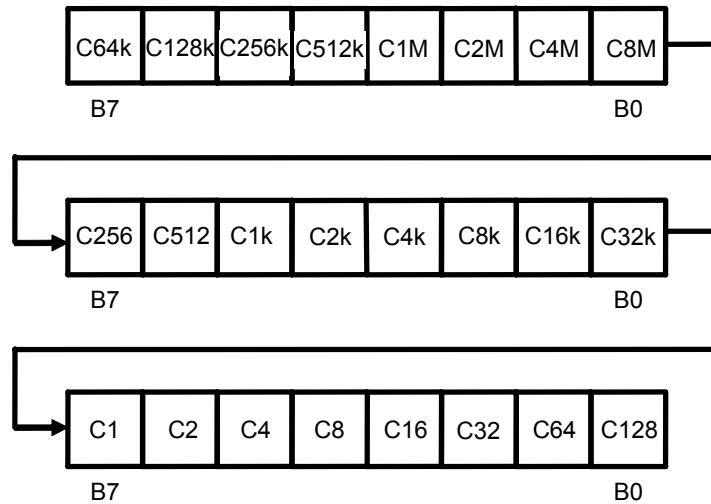


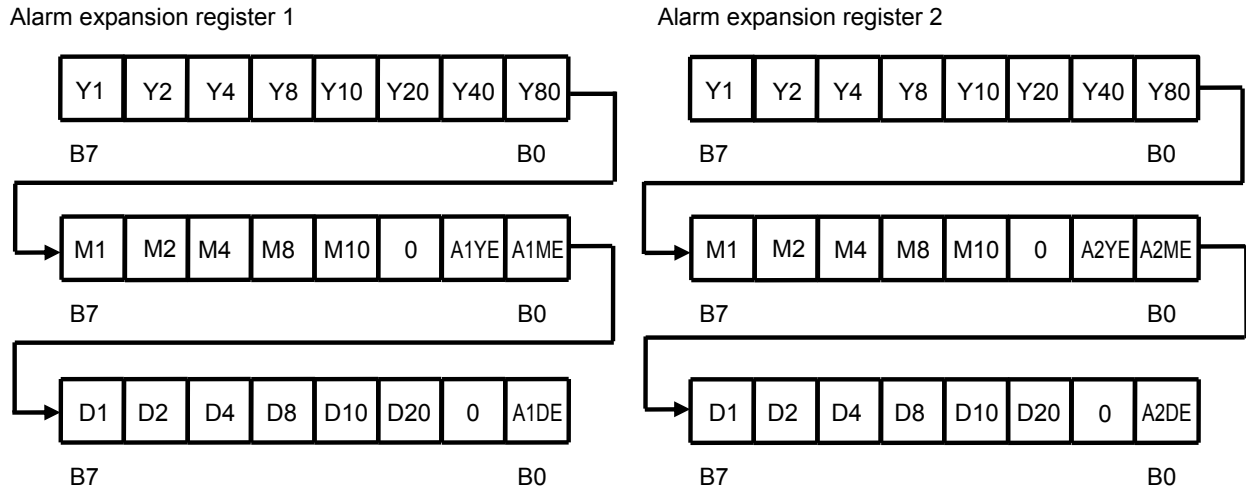
Figure 19 Up Counter

Table 13 Example of Count Value and Reading Data in Register

Count Value	Reading Data in Register
000001 h	000080 h
000002 h	000040 h
•	•
•	•
•	•
FFFFFF h	F7FFFF h
•	•
•	•
•	•
FFFFFF h	FFFFFF h

**8. Alarm expansion register 1 and alarm expansion register 2**

The alarm expansion register 1 and 2 are 3-byte registers. They are expansion registers for the INT1 and INT2 registers which output alarm interrupt. Users are able to set the alarm time; the data of year, month, day. The configuration of register is expressed by BCD code as well as the data register of year, month, day in the real-time register.



**Figure 20 Alarm Expansion Register 1 and Alarm Expansion Register 2**

To make the year data of alarm expansion register 1 valid, set A1YE to "1". For the month data, set A1ME to "1", for the day data, set A1DE to "1". Set as well A2ME, A2YE, A2DE in the alarm expansion register 2. Regarding how to set the data of day of the week, hour, and minute, refer to "4. 1 Alarm interrupt" in "4. INT1 register and INT2 register".

Setting example: Setting alarm time "January 31, 2015" in the alarm expansion register 1

Writing to alarm expansion register 1

Year	1	0	1	0	1	0	0	0
Month	1	0	0	0	0	-*1	1	1
Day	1	0	0	0	1	1	-*1	1
	B7				B0			

\*1. Don't care (both of 0 and 1 are acceptable.)

■ **Power-on Detection Circuit and Register Status**

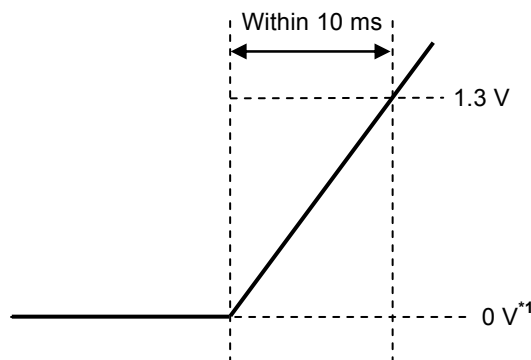
The power-on detection circuit operates by power-on the S-35399A03, as a result each register is cleared; each register is set as follows.

Real-time data register:	00 (Y), 01 (M), 01 (D), 0 (day of the week), 00 (H), 00 (M), 00 (S)
Status register 1:	"01h"
Status register 2:	"80h"
INT1 register:	"80h"
INT2 register:	"00h"
Clock correction register:	"00h"
Free register 1:	"00h"
Free register 2:	"00h"
Free register 3:	"00h"
Up counter:	"00 00 00h"
Alarm expansion register 1:	"00h"
Alarm expansion register 2:	"00h"

"1" is set in the POC flag (B0 in the status register 1) to indicate that power has been applied. To correct the oscillation frequency, the status register 2 goes in the mode the output of user-set frequency, so that 1 Hz clock pulse is output from the  $\overline{\text{INT1}}$  pin. When "1" is set in the POC flag, be sure to initialize. The POC flag is set to "0" due to initialization so that the output of user-set frequency mode is cleared (Refer to "■ Register Status After Initialization").

For the regular operation of power-on detection circuit, as seen in **Figure 21**, the period to power-up the S-35399A03 is that the voltage reaches 1.3 V within 10 ms after setting the IC's power supply voltage at 0 V. When the power-on detection circuit is not working normally is; the POC flag (B0 in the status register 1) is not in "1", or 1 Hz is not output from the  $\overline{\text{INT1}}$  pin. In this case, power-on the S-35399A03 once again because the internal data may be in the indefinite status.

Moreover, regarding the processing right after power-on, refer to "■ Flowchart of Initialization and Example of Real-time Data Set-up".



\*1. 0 V indicates that there are no potential differences between the VDD pin and VSS pin of the S-35399A03.

**Figure 21 How to Raise the Power Supply Voltage**



■ **Low Power Supply Voltage Detection Circuit**

The S-35399A03 has a low power supply voltage detection circuit, so that users can monitor drops in the power supply voltage by reading the BLD flag (B1 in the status register 1). There is a hysteresis width of approx. 0.15 V typ. between detection voltage and release voltage (refer to "■ Characteristics (Typical Data)"). The low power supply voltage detection circuit does the sampling operation only once in one sec for 15.6 ms.

If the power supply voltage decreases to the level of detection voltage ( $V_{DET}$ ) or less, "1" is set to the BLD flag so that sampling operation stops. Once "1" is detected in the BLD flag, no sampling operation is performed even if the power supply voltage increases to the level of release voltage or more, and "1" is held in the BLD flag.

Furthermore, the S-35399A03 does not initialize the internal circuit even if "1" is set to the BLD flag. If the BLD flag is "1" even after the power supply voltage is recovered, the internal circuit may be in the indefinite status. In this case, be sure to initialize the circuit. Without initializing, if the next BLD flag reading is done after sampling, the BLD flag gets reset to "0". In this case, be sure to initialize although the BLD flag is in "0" because the internal circuit may be in the indefinite status.

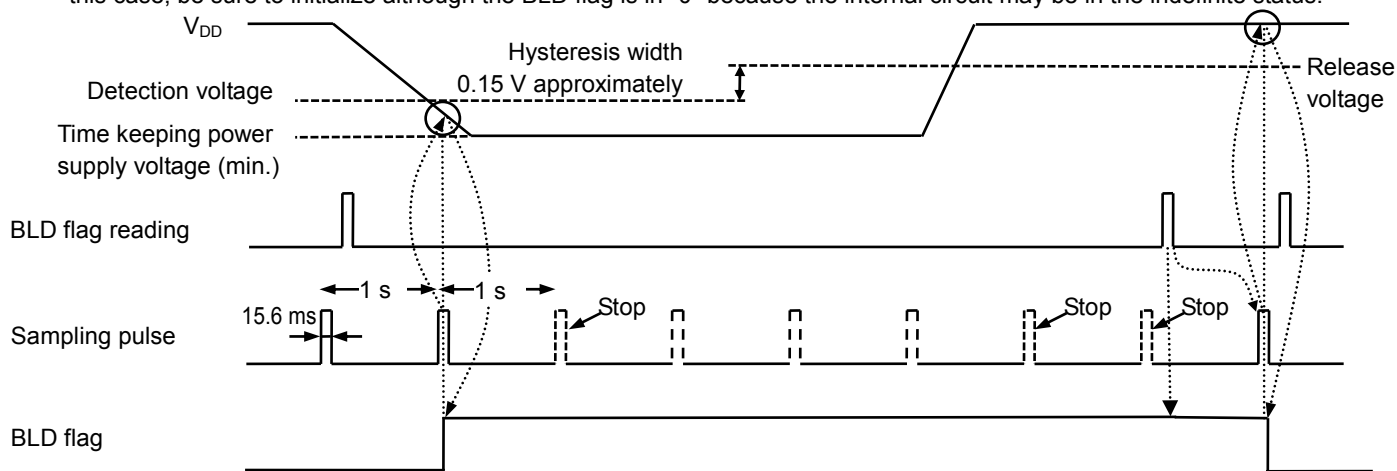


Figure 23 Timing of Low Power Supply Voltage Detection Circuit

■ **Circuits Power-on and Low Power Supply Voltage Detection**

Figure 24 shows the changes of the POC flag and BLD flag due to  $V_{DD}$  fluctuation.

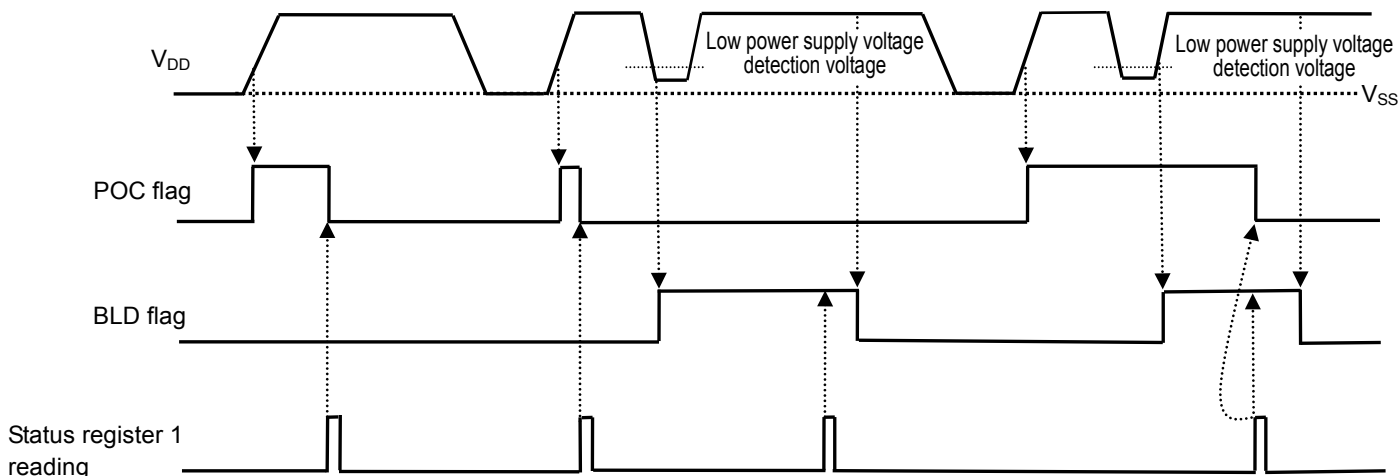


Figure 24 POC Flag and BLD Flag

## ■ Correction of Nonexistent Data and End-of-Month

When users write the real-time data, the S-35399A03 checks it. In case that the data is invalid, the S-35399A03 does the following procedures.

### 1. Processing of nonexistent data

Table 14 Processing of Nonexistent Data

Register	Normal Data	Nonexistent Data	Result
Year data	00 to 99	XA to XF, AX to FX	00
Month data	01 to 12	00, 13 to 19, XA to XF	01
Day data	01 to 31	00, 32 to 39, XA to XF	01
Day of week data	0 to 6	7	0
Hour data *1	24-hour	0 to 23	24 to 29, 3X, XA to XF
	12-hour	0 to 11	12 to 20, XA to XF
Minute data	00 to 59	60 to 79, XA to XF	00
Second data *2	00 to 59	60 to 79, XA to XF	00

\*1. In 12-hour mode, write the  $\overline{\text{AM}} / \text{PM}$  flag (B1 in hour data in the real-time data register).

In 24-hour mode, the  $\overline{\text{AM}} / \text{PM}$  flag in the real-time data register is omitted. However in the flag of reading, users are able to read 0; 0 to 11, 1; 12 to 23.

\*2. Processing of nonexistent data, regarding second data, is done by a carry pulse which is generated in 1 second, after writing. At this point the carry pulse is sent to the minute-counter.

### 2. Correction of end-of-month

A nonexistent day, such as February 30 and April 31, is set to the first day of the next month.

## ■ $\overline{\text{INT1}}$ , $\overline{\text{INT2}}$ Pin Output Modes

These are selectable for the output mode for  $\overline{\text{INT1}}$  and  $\overline{\text{INT2}}$  pins;

Alarm interrupt, the output of user-set frequency, per-minute edge interrupt output, minute-periodical interrupt output 1. In the  $\overline{\text{INT1}}$  pin output mode, in addition to the above modes, minute-periodical interrupt output 2 and 32.768 kHz output are also selectable.

To switch the output mode, use the status register 2. Refer to "3. status register 2" in "■ Configuration of Registers".

When switching the output mode, be careful of the output status of the pin. Especially, when using alarm interrupt / output of frequency, switch the output mode after setting "00h" in the INT1 / INT2 register. In 32.768 kHz output / per-minute edge interrupt output / minute-periodical interrupt output, it is unnecessary to set data in the INT1 / INT2 register for users.

Refer to the followings regarding each operation of output modes.

### 1. Alarm interrupt output

Alarm interrupt output is the function to output "L" from the  $\overline{\text{INT1}}$  /  $\overline{\text{INT2}}$  pin, at the alarm time which is set by user has come. If setting the pin output to "H", turn off the alarm function by setting "0" in INT1AE / INT2AE in the status register 2. To set the alarm time, set the data of day of the week, hour, minute in the INT1 / INT2 register, set the data of year, month, day in the alarm expansion register 1 or 2. Refer to "4. INT1 register and INT2 register" and "8. Alarm expansion register 1 and alarm expansion register 2" in "■ Configuration of Registers".

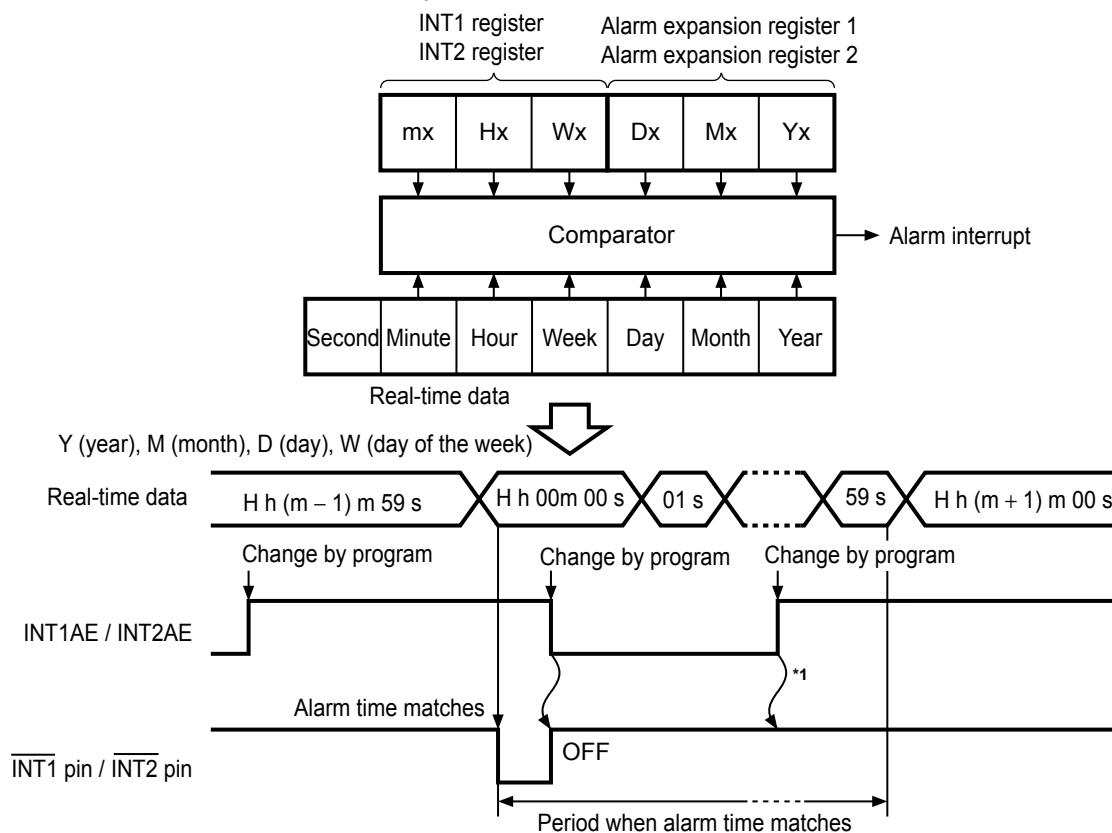
#### 1.1 Alarm setting of "Y (year), M (month), D (day), W (day of the week), H (hour), m (minute)"

Status register 2 setting

- INT1 pin output mode  
32kE = 0, INT1ME = INT1FE = 0
- INT2 pin output mode  
INT2ME = INT2FE = 0

INTx register alarm enable flag

- AxHE = AxmE = AxWE = "1"
- Alarm expansion register x alarm enable flag
- AxYE = AxME = AxDE = "1"

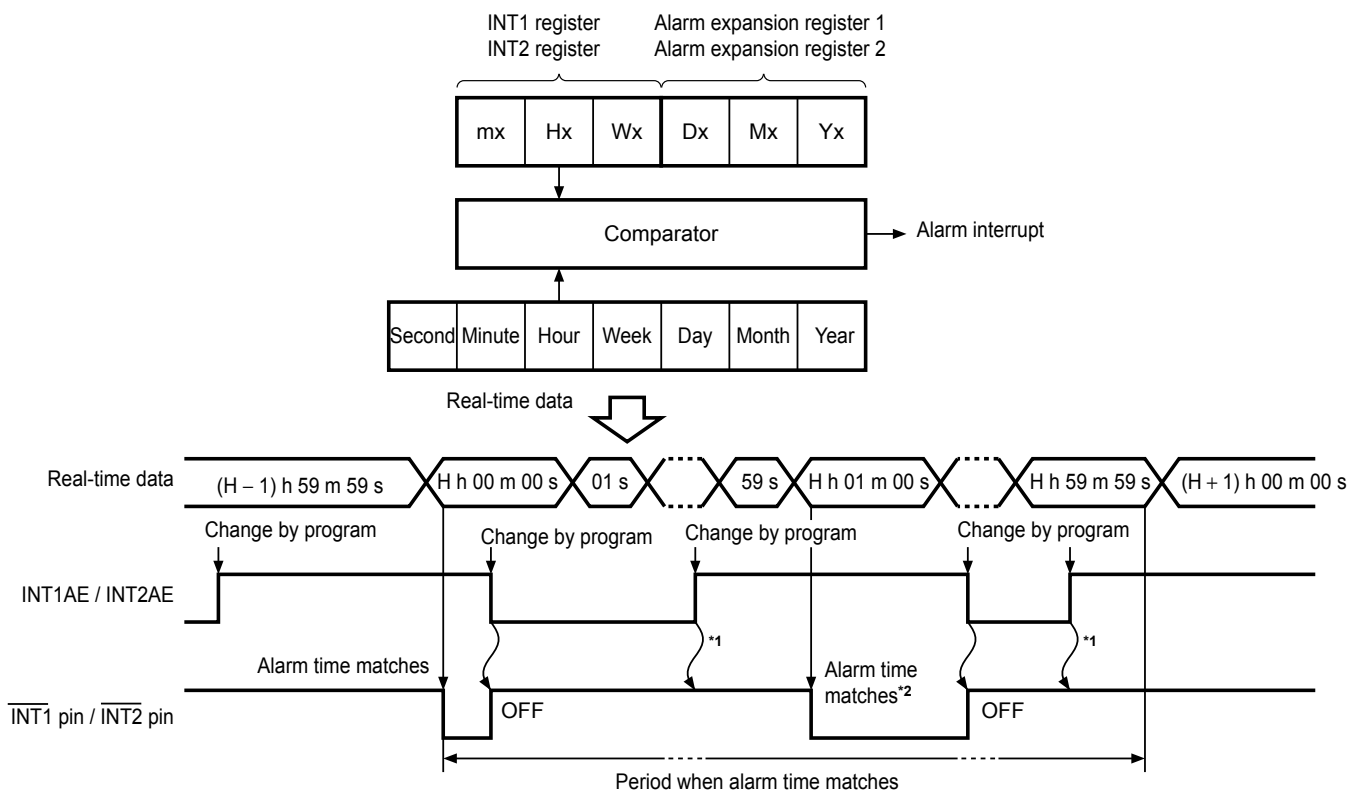


\*1. If users clear INT1AE / INT2AE once; "L" is not output from the  $\overline{\text{INT1}}$  /  $\overline{\text{INT2}}$  pin by setting INT1AE / INT2AE enable again, within a period when the alarm time matches real-time data.

Figure 25 Alarm Interrupt Output Timing

1.2 Alarm setting of "H (hour)"

- |   |  |
|---|--|
| <p>Status register 2 setting</p> <ul style="list-style-type: none"> <li>• <math>\overline{INT1}</math> pin output mode<br/>32kE = 0, INT1ME = INT1FE = 0</li> <li>• <math>\overline{INT2}</math> pin output mode<br/>INT2ME = INT2FE = 0</li> </ul> | <p>INTx register alarm enable flag</p> <ul style="list-style-type: none"> <li>• AxHE = AxmE = AxWE = "1"</li> </ul> <p>Alarm expansion register x alarm enable flag</p> <ul style="list-style-type: none"> <li>• AxYE = AxME = AxDE = "1"</li> </ul> |
|---|--|



- \*1. If users clear INT1AE / INT2AE once; "L" is not output from the  $\overline{INT1}$  /  $\overline{INT2}$  pin by setting INT1AE / INT2AE enable again, within a period when the alarm time matches real-time data.
- \*2. If turning the alarm output on by changing the program, within the period when the alarm time matches real-time data, "L" is output again from the  $\overline{INT1}$  /  $\overline{INT2}$  pin when the minute is counted up.

Figure 26 Alarm Interrupt Output Timing

2. Output of user-set frequency

The output of user-set frequency is the function to output the frequency which is selected by using data, from the  $\overline{INT1}$  /  $\overline{INT2}$  pin, in the AND-form. Set up the data of frequency in the INT1 / INT2 register. Refer to "4. INT1 register and INT2 register" in "■ Configuration of Registers".

- Status register 2 setting
- INT1 pin output mode  
32kE = 0, INT1AE = Don't care (0 or 1), INT1ME = 0
  - INT2 pin output mode  
INT2AE = Don't care (0 or 1), INT2ME = 0



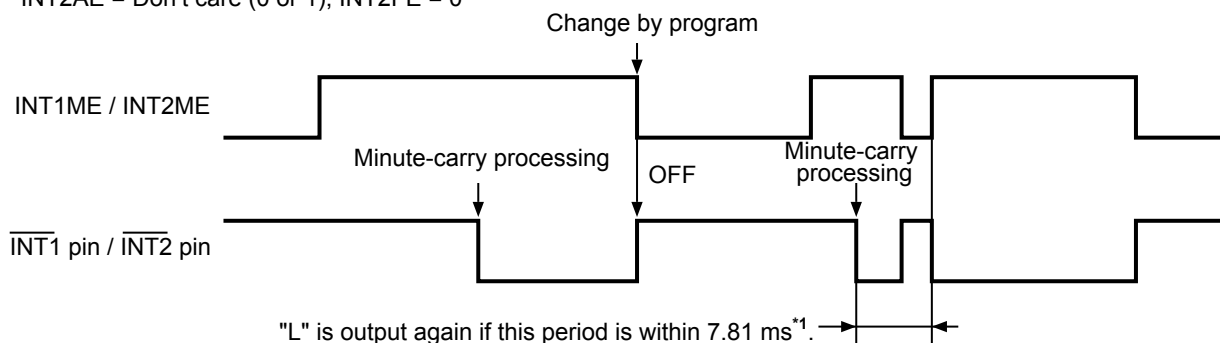
Figure 27 Output Timing of User-set Frequency

**3. Per-minute edge interrupt output**

Per-minute edge interrupt output is the function to output "L" from the  $\overline{\text{INT1}}$  /  $\overline{\text{INT2}}$  pin, when the first minute-carry processing is done, after selecting the output mode. To set the pin output to "H", turn off the output mode of per-minute edge interrupt. In the  $\overline{\text{INT1}}$  pin output mode, input "0" in INT1ME in the status register 2. In the  $\overline{\text{INT2}}$  pin output mode, input "0" in INT2ME.

Status register 2 setting

- $\overline{\text{INT1}}$  pin output mode  
 32kE = 0, INT1AE = Don't care (0 or 1), INT1FE = 0
- $\overline{\text{INT2}}$  pin output mode  
 INT2AE = Don't care (0 or 1), INT2FE = 0



\*1. Pin output is set to "H" by disabling the output mode within 7.81 ms, because the signal of this procedure is maintained for 7.81 ms. Note that pin output is set to "L" by setting enable the output mode again.

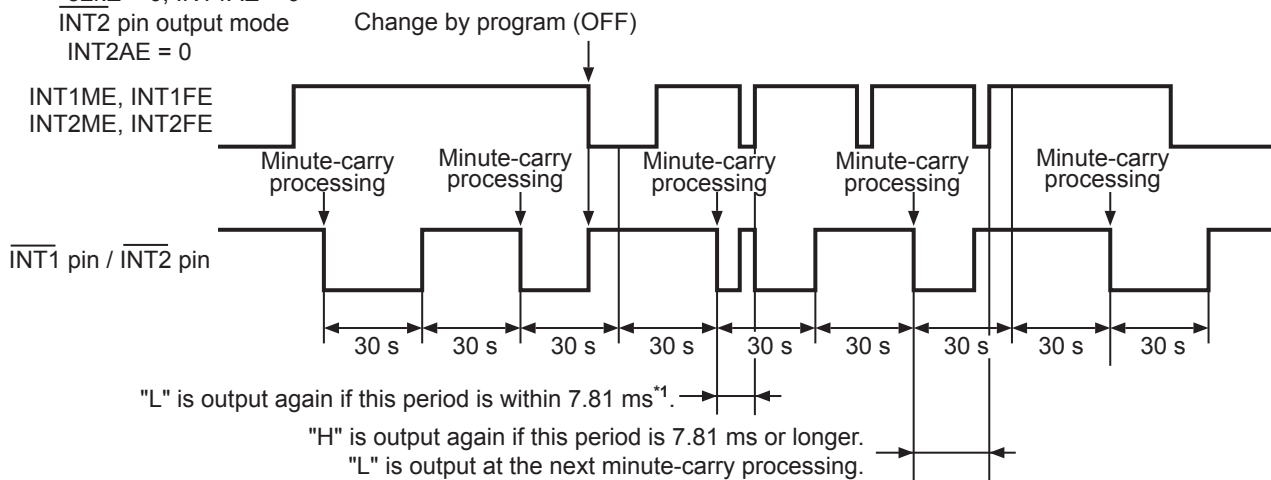
**Figure 28 Timing of Per-Minute Edge Interrupt Output**

**4. Minute-periodical interrupt output 1**

The minute-periodical interrupt 1 is the function to output the one-minute clock pulse (Duty 50%) from the  $\overline{\text{INT1}}$  /  $\overline{\text{INT2}}$  pin, when the first minute-carry processing is done, after selecting the output mode.

Status register 2 setting

- $\overline{\text{INT1}}$  pin output mode  
 32kE = 0, INT1AE = 0
- $\overline{\text{INT2}}$  pin output mode  
 INT2AE = 0



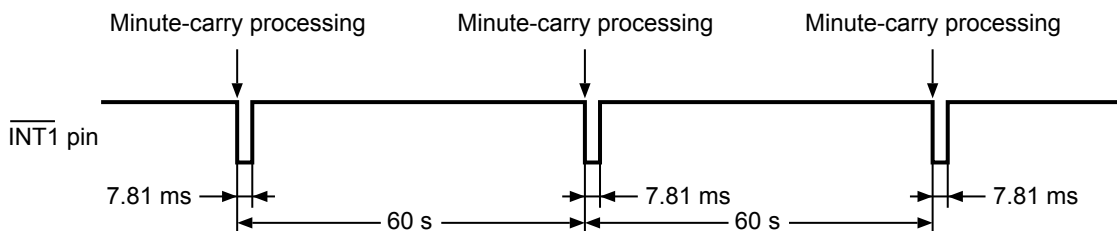
\*1. Setting the output mode disable makes the pin output "H", while the output from the  $\overline{\text{INT1}}$  /  $\overline{\text{INT2}}$  pin is in "L". Note that pin output is set to "L" by setting the output mode enable again.

**Figure 29 Timing of Minute-periodical Interrupt Output 1**

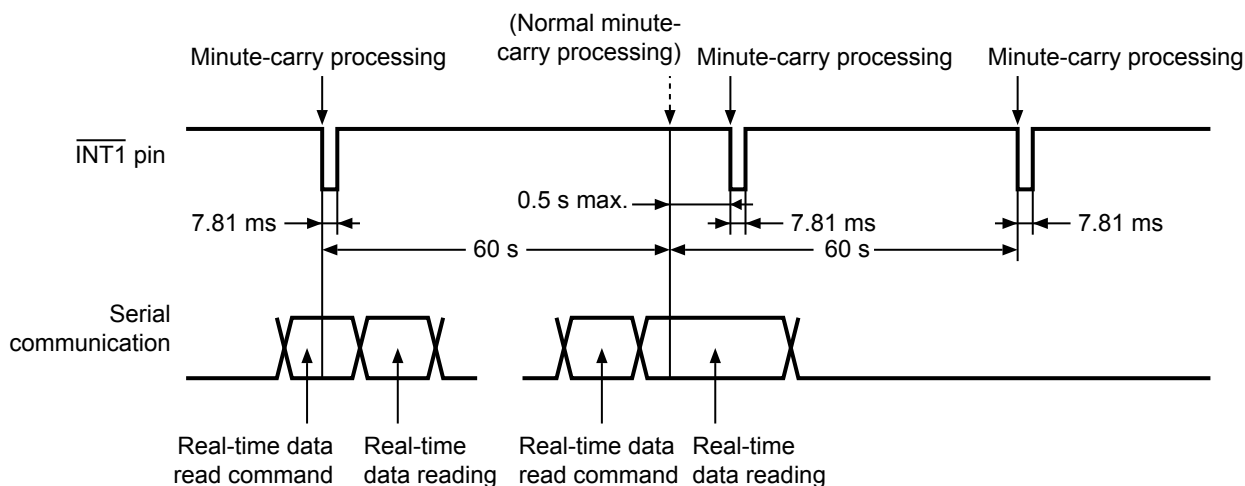
**5. Minute-periodical interrupt output 2 (only in the  $\overline{\text{INT1}}$  pin output mode)**

The output of minute-periodical interrupt 2 is the function to output "L", for 7.81 ms, from the  $\overline{\text{INT1}}$  pin, synchronizing with the first minute-carry processing after selecting the output mode. However, during reading in the real-time data register, the procedure delays at 0.5 seconds max. thus output "L" from the  $\overline{\text{INT1}}$  pin also delays at 0.5 seconds max. During writing in the real-time data register, some delay is made in the output period due to write timing and the second-data of writing.

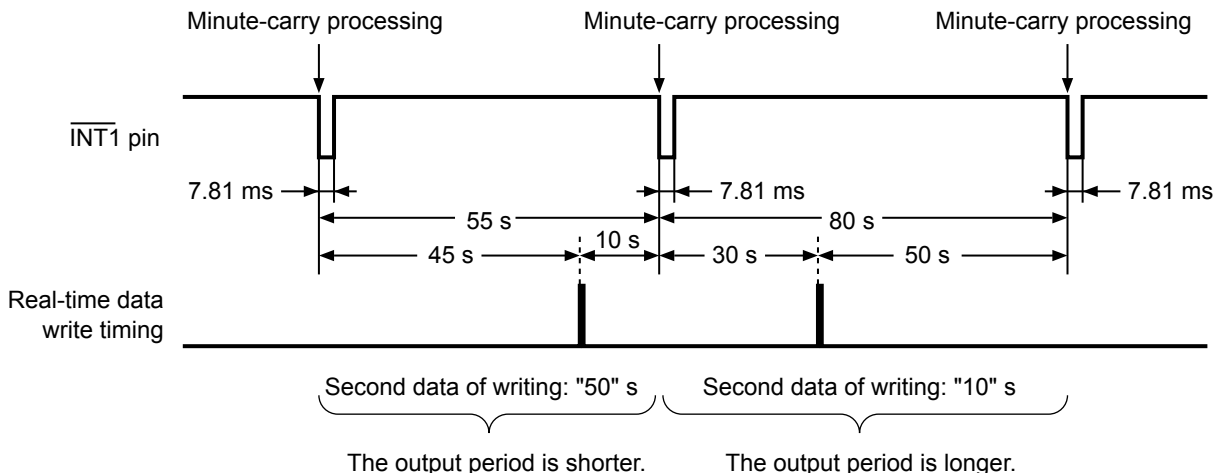
**(1) During normal operation**



**(2) During reading operation in the real-time data register**



**(3) During writing operation in the real-time data register**



**Figure 30 Timing of Minute-periodical Interrupt Output 2**

6. Operation of power-on detection circuit (only in the  $\overline{\text{INT1}}$  pin output mode)

When power is applied to the S-35399A03, the power-on detection operates to set "1" in the POC flag (B0 in the status register 1). A 1 Hz clock pulse is output from the  $\overline{\text{INT1}}$  pin.

Status register 2 setting

- 32kE = 0, INT1AE = INT1ME = 0

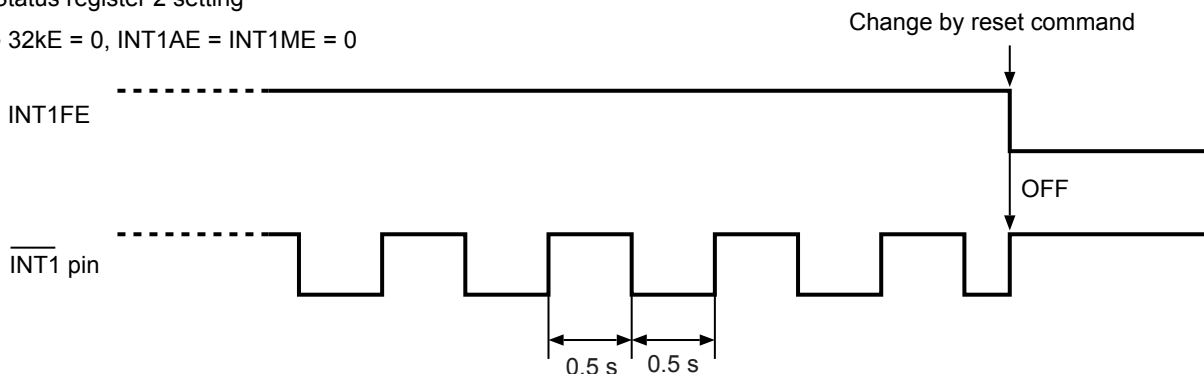


Figure 31 Output Timing of  $\overline{\text{INT1}}$  Pin during Operation of Power-on Detection Circuit

■ Function of Clock Correction

The function of clock correction is to correct advance / delay of the clock due to the deviation of oscillation frequency, in order to make a high precise clock. For correction, the S-35399A03 adjusts the clock pulse by using a certain part of the dividing circuit, not adjusting the frequency of the crystal oscillator. Correction is performed once every 20 seconds (or 60 seconds). The minimum resolution is approx. 3 ppm (or approx. 1 ppm) and the S-35399A03 corrects in the range of -195.3 ppm to +192.2 ppm (or of -65.1 ppm to +64.1 ppm). (Refer to **Table 15.**) Users can set up this function by using the clock correction register. Regarding how to calculate the setting data, refer to "1. How to calculate". When not using this function, be sure to set "00h".

Table 15 Function of Clock Correction

Item	B0 = 0	B0 = 1
Adjustment	Every 20 seconds	Every 60 seconds
Minimum resolution	3.052 ppm	1.017 ppm
Correction range	-195.3 ppm to +192.2 ppm	-65.1 ppm to +64.1 ppm

## 1. How to calculate

### 1.1 If current oscillation frequency > target frequency (in case the clock is fast)

$$\text{Correction value}^{*1} = 128 - \text{Integral value} \left( \frac{(\text{Current oscillation frequency actual measurement value}^{*2}) - (\text{Target oscillation frequency}^{*3})}{(\text{Current oscillation frequency actual measurement value}^{*2}) \times (\text{Minimum resolution}^{*4})} \right)$$

**Caution** The figure range which can be corrected is that the calculated value is from 0 to 64.

- \*1. Convert this value to be set in the clock correction register. For how to convert, refer to "(1) Calculation example 1".
- \*2. Measurement value when 1 Hz clock pulse is output from the  $\overline{\text{INT1}}$  /  $\overline{\text{INT2}}$  pin.
- \*3. Target value of average frequency when the clock correction function is used.
- \*4. Refer to "Table 15 Function of Clock Correction".

#### (1) Calculation example 1

In case of current oscillation frequency actual measurement value = 1.000070 [Hz], target oscillation frequency = 1.000000 [Hz], B0 = 0 (Minimum resolution = 3.052 ppm)

$$\begin{aligned} \text{Correction value} &= 128 - \text{Integral value} \left( \frac{(1.000070) - (1.000000)}{(1.000070) \times (3.052 \times 10^{-6})} \right) \\ &= 128 - \text{Integral value} (22.93) = 128 - 22 = 106 \end{aligned}$$

Convert the correction value "106" to 7-bit binary and obtain "1101010b".

Reverse the correction value "1101010b" and set it to B7 to B1 of the clock correction register.

Thus, set the clock correction register:

(B7, B6, B5, B4, B3, B2, B1, B0) = (0, 1, 0, 1, 0, 1, 1, 0)

### 1.2 If current oscillation frequency < target frequency (in case the clock is slow)

$$\text{Correction value} = \text{Integral value} \left( \frac{(\text{Target oscillation frequency}) - (\text{Current oscillation frequency actual measurement value})}{(\text{Current oscillation frequency actual measurement value}) \times (\text{Minimum resolution})} \right) + 1$$

**Caution** The figure range which can be corrected is that the calculated value is from 0 to 62.

#### (1) Calculation example 2

In case of current oscillation frequency actual measurement value = 0.999920 [Hz], target oscillation frequency = 1.000000 [Hz]. B0 = 0 (Minimum resolution = 3.052 ppm)

$$\begin{aligned} \text{Correction value} &= \text{Integral value} \left( \frac{(1.000000) - (0.999920)}{(0.999920) \times (3.052 \times 10^{-6})} \right) + 1 \\ &= \text{Integral value} (26.21) + 1 = 26 + 1 = 27 \end{aligned}$$

Thus, set the clock correction register:

(B7, B6, B5, B4, B3, B2, B1, B0) = (1, 1, 0, 1, 1, 0, 0, 0)

#### (2) Calculation example 3

In case of current oscillation frequency actual measurement value = 0.999920 [Hz], target oscillation frequency = 1.000000 [Hz], B0 = 1 (Minimum resolution = 1.017 ppm)

$$\begin{aligned} \text{Correction value} &= \text{Integral value} \left( \frac{(1.000000) - (0.999920)}{(0.999920) \times (1.017 \times 10^{-6})} \right) + 1 \\ &= \text{Integral value} (78.66) + 1 \end{aligned}$$

This calculated value exceeds the correctable range 0 to 62.

B0 = "1" (minimum resolution = 1.017 ppm) indicates the correction is impossible.

**2. Setting values for registers and correction values**

**Table 16 Setting Values for Registers and Correction Values (Minimum Resolution: 3.052 ppm (B0 = 0))**

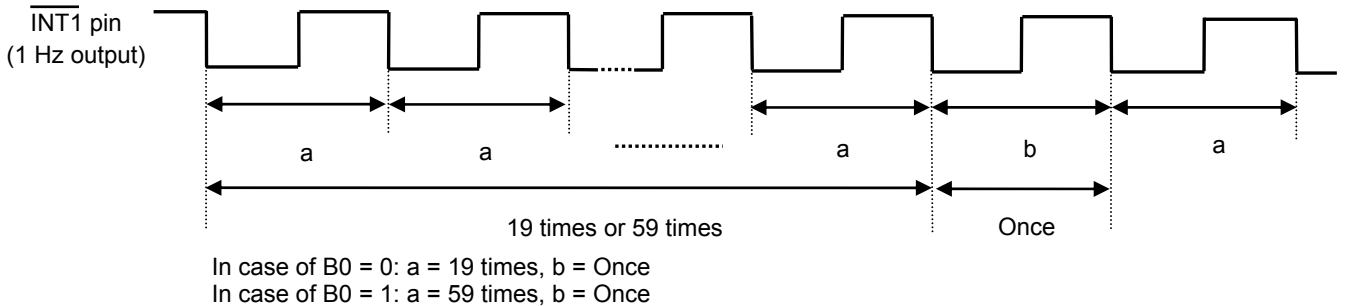
B7	B6	B5	B4	B3	B2	B1	B0	Correction Value [ppm]	Rate [s / day]
1	1	1	1	1	1	0	0	192.3	16.61
0	1	1	1	1	1	0	0	189.2	16.35
1	0	1	1	1	1	0	0	186.2	16.09
• • •								• • •	• • •
0	1	0	0	0	0	0	0	6.1	0.53
1	0	0	0	0	0	0	0	3.1	0.26
0	0	0	0	0	0	0	0	0	0
1	1	1	1	1	1	1	0	-3.1	-0.26
0	1	1	1	1	1	1	0	-6.1	-0.53
1	0	1	1	1	1	1	0	-9.2	-0.79
• • •								• • •	• • •
0	1	0	0	0	0	1	0	-189.2	-16.35
1	0	0	0	0	0	1	0	-192.3	-16.61
0	0	0	0	0	0	1	0	-195.3	-16.88

**Table 17 Setting Values for Registers and Correction Values (Minimum Resolution: 1.017 ppm (B0 = 1))**

B7	B6	B5	B4	B3	B2	B1	B0	Correction Value [ppm]	Rate [s / day]
1	1	1	1	1	1	0	1	64.1	5.54
0	1	1	1	1	1	0	1	63.1	5.45
1	0	1	1	1	1	0	1	62.0	5.36
• • •								• • •	• • •
0	1	0	0	0	0	0	1	2.0	0.18
1	0	0	0	0	0	0	1	1.0	0.09
0	0	0	0	0	0	0	1	0	0
1	1	1	1	1	1	1	1	-1.0	-0.09
0	1	1	1	1	1	1	1	-2.0	-0.18
1	0	1	1	1	1	1	1	-3.0	-0.26
• • •								• • •	• • •
0	1	0	0	0	0	1	1	-63.1	-5.45
1	0	0	0	0	0	1	1	-64.1	-5.54
0	0	0	0	0	0	1	1	-65.1	-5.62

**3. How to confirm setting value for register and result of correction**

The S-35399A03 does not adjust the frequency of the crystal oscillation by using the clock correction function. Therefore users cannot confirm if it is corrected or not by measuring output 32.768 kHz. When the function of clock correction is being used, the cycle of 1 Hz clock pulse output from the INT1 pin changes once in 20 times or 60 times, as shown in Figure 32.



**Figure 32 Confirmation of Clock Correction**

Measure a and b by using the frequency counter\*1. Calculate the average frequency (Tave) based on the measurement results.

B0 = 0,  $T_{ave} = (a \times 19 + b) \div 20$

B0 = 1,  $T_{ave} = (a \times 59 + b) \div 60$

Calculate the error of the clock based on the average frequency (Tave). The following shows an example for confirmation.

Confirmation example: When B0 = 0, 66h is set

Measurement results: a = 1.000080 Hz, b = 0.998493 Hz

	Clock Correction Register Setting Value	Average Frequency [Hz]	Per Day [s]
Before correction	00 h (Tave = a)	1.000080	86393
After correction	66 h (Tave = (a × 19 + b) ÷ 20)	1.00000065	86399.9

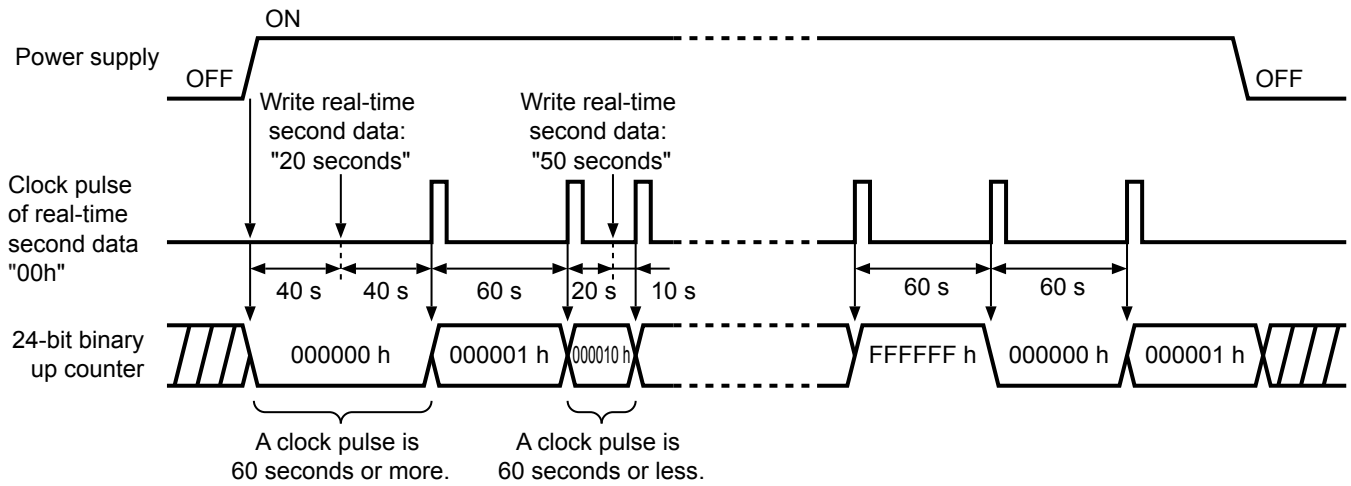
Calculating the average frequency allows to confirm the result of correction.

\*1. Use a high-accuracy frequency counter of 7 digits or more.

**Caution** Measure the oscillation frequency under the usage conditions.

■ **Up-Count Operation**

The up counter is a 24-bit read-only binary counter. This counter starts counting from "000000 h" from power-on and returns to "000000 h" at the next clock after it has reached "FFFFFF h". A clock pulse is a pulse that is output when the second-data in the real-time data is "00h". Therefore, some delay is made in the period that a clock pulse is being output due to write timing and write data. The registers are not initialized unless power-on again, so that users are able to grasp the elapsed time from power-on up to 30 years. **Figure 33** shows the example of timing chart of up counter's operation.



**Figure 33** Timing Chart of 24-Bit Binary Up Counter

■ Serial Interface

The S-35399A03 transmits / receives various commands via I<sup>2</sup>C-bus serial interface to read / write data. Regarding transmission is as follows.

1. Start condition

A start condition is when the SDA line changes "H" to "L" when the SCL line is in "H", so that the access starts.

2. Stop condition

A stop condition is when the SDA line changes "L" to "H" when the SCL line is in "H", and the access stops, so that the S-35399A03 gets standby.

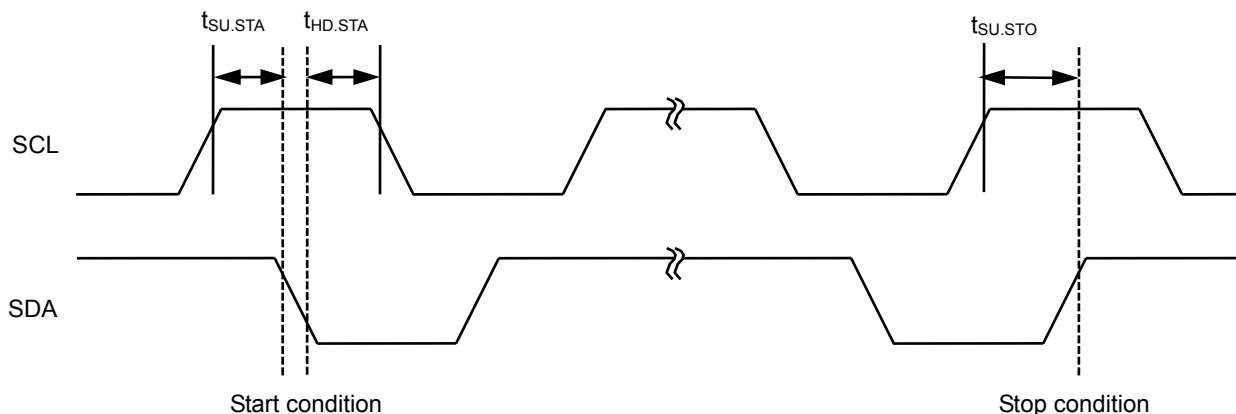


Figure 34 Start / Stop Conditions

3. Data transmission and acknowledgment signal

Data transmission is performed for every 1-byte, after detecting a start condition. Transmit data while the SCL line is in "L", and be careful of spec of  $t_{SU.DAT}$  and  $t_{HD.DAT}$  when changing the SDA line. If the SDA line changes while the SCL line is in "H", the data will be recognized as start / stop condition in spite of data transmission. Note that by this case, the access will be interrupted.

During data transmission, every moment receiving 1-byte data, the devices which work for receiving data send an acknowledgment signal back. For example, as seen in Figure 35, in case that the S-35399A03 is the device working for receiving data and the master device is the one working for sending data; when the 8-bit clock pulse falls, the master device releases the SDA line. After that, the S-35399A03 sends an acknowledgment signal back, and set the SDA line to "L" at the 9-bit clock pulse. The S-35399A03 does not output an acknowledgment signal is that the access is not being done regularly.

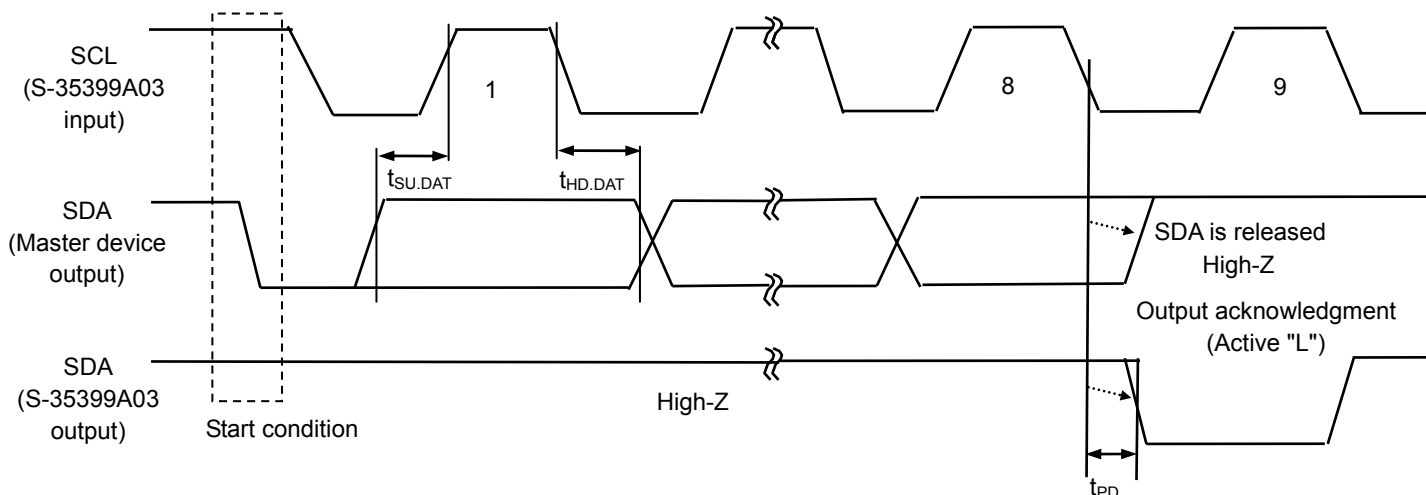
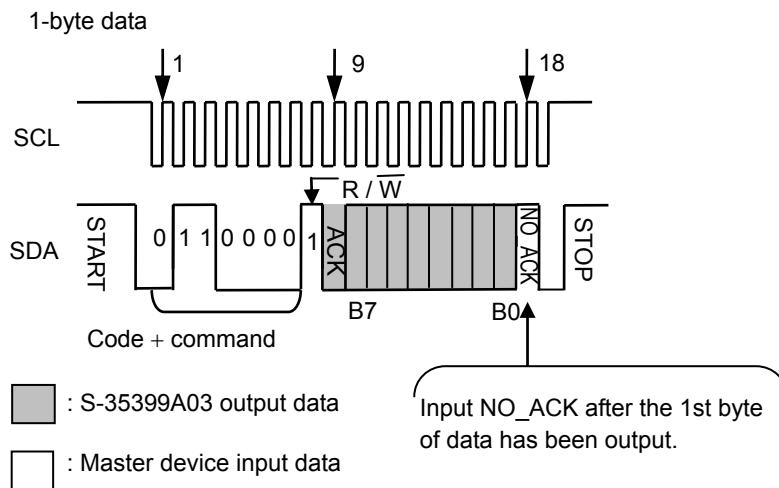


Figure 35 Output Timing of Acknowledgment Signal

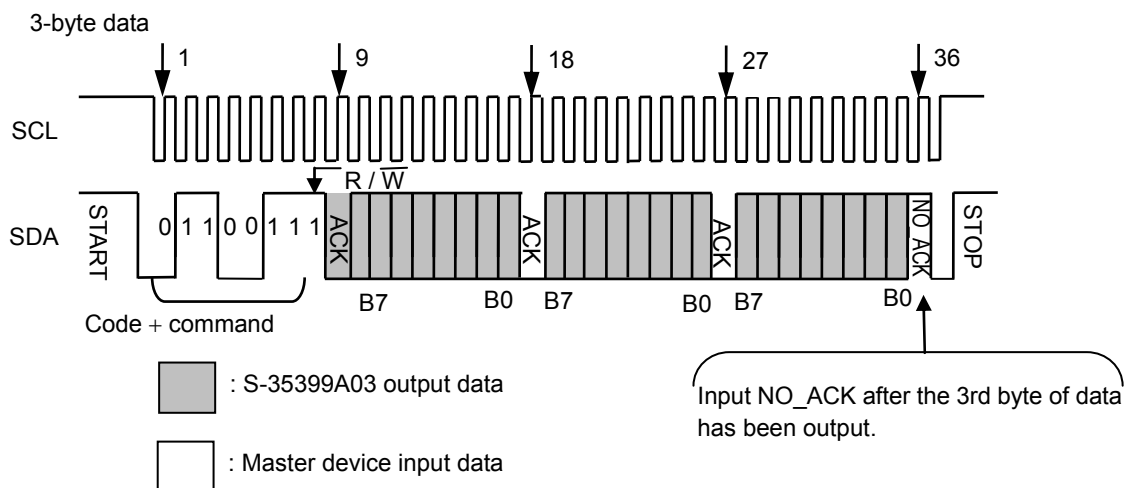
The followings are data reading / writing in the S-35399A03.

**3.1 Data reading in the S-35399A03**

After detecting a start condition, the S-35399A03 receives device code and command. The S-35399A03 enters the read-data mode by the read / write bit "1". The data is output from B7 in 1-byte. Input an acknowledgment signal from the master device every moment that the S-35399A03 outputs 1-byte data. However, do not input an acknowledgment signal (input NO\_ACK) for the last data-byte output from the master device. This procedure notifies the completion of reading. Next, input a stop condition to the S-35399A03 to finish access.



**Figure 36 Example of Data Reading 1 (1-Byte Data Register)**



**Figure 37 Example of Data Reading 2 (3-Byte Data Register)**

3.2 Data writing in the S-35399A03

After detecting a start condition, S-35399A03 receives device code and command. The S-35399A03 enters the write-data mode by the read / write bit "0". Input data from B7 to B0 in 1-byte. The S-35399A03 outputs an acknowledgment signal "L" every moment that 1-byte data is input. After receiving the acknowledgment signal which is for the last byte-data, input a stop condition to the S-35399A03 to finish access.

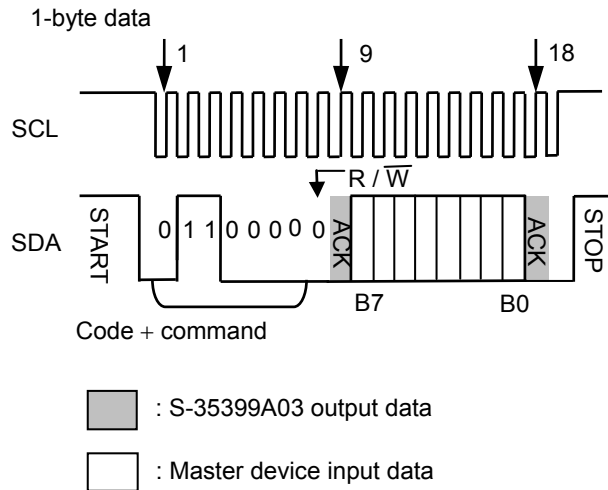


Figure 38 Example of Data Writing 1 (1-Byte Data Register)

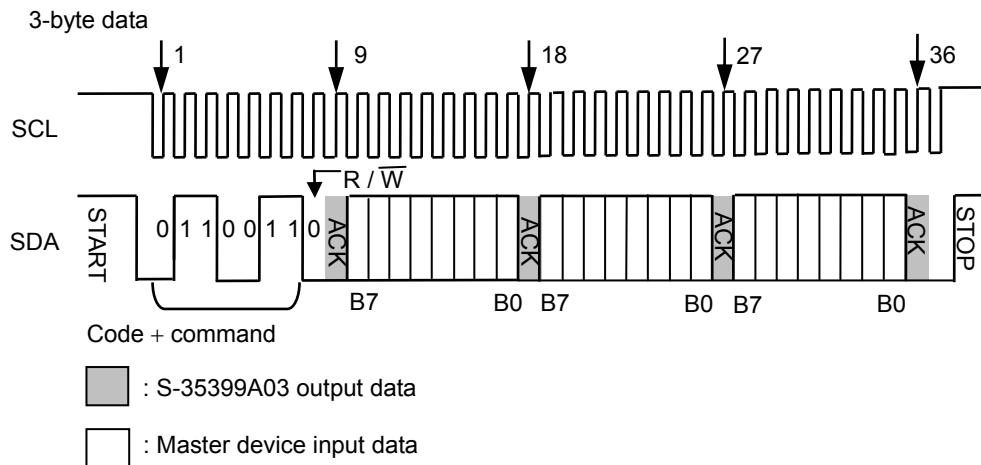
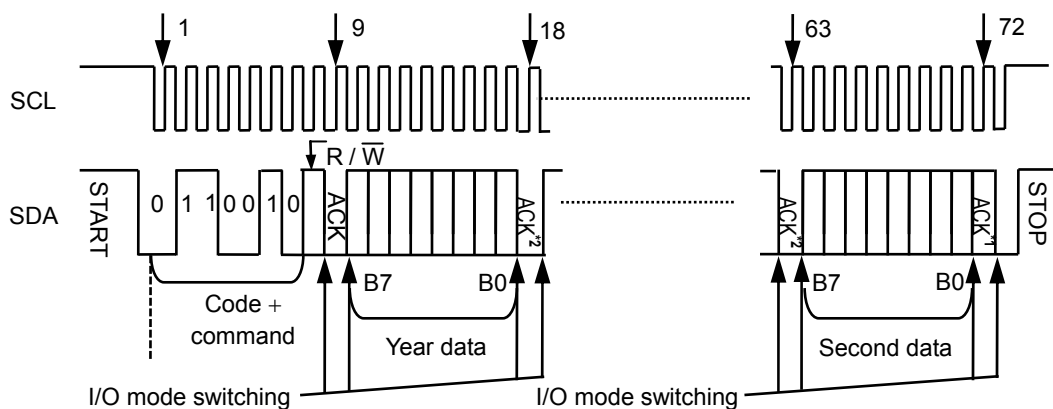


Figure 39 Example of Data Reading 2 (3-Byte Data Register)

4. Data access

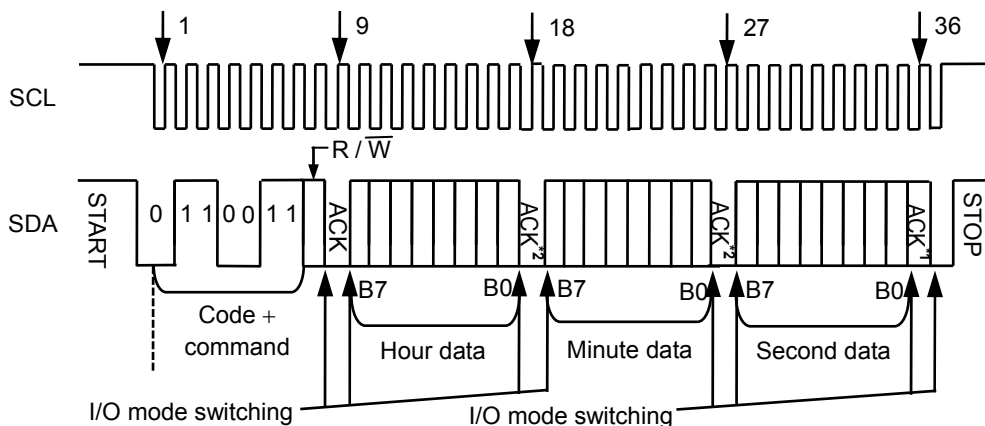
4.1 Real-time data 1 access



- \*1. Set NO\_ACK = 1 when reading.
- \*2. Transmit ACK = 0 from the master device to the S-35399A03 when reading.

Figure 40 Real-Time Data 1 Access

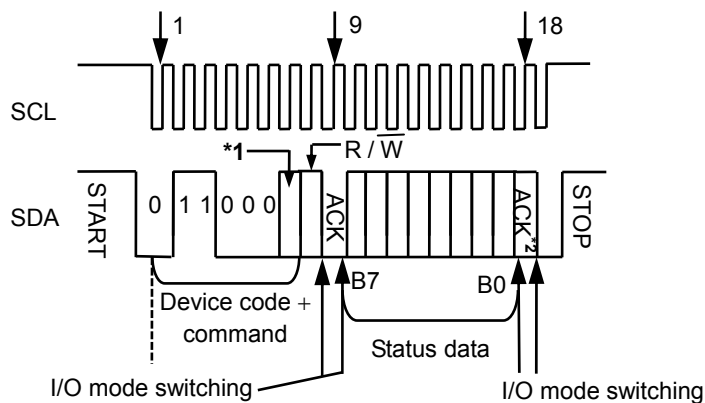
4.2 Real-time data 2 access



- \*1. Set NO\_ACK = 1 when reading.
- \*2. Transmit ACK = 0 from the master device to the S-35399A03 when reading.

Figure 41 Real-Time Data 2 Access

4.3 Status register 1 access and status register 2 access



- \*1. 0: Status register 1 selected, 1: Status register 2 selected
- \*2. Set NO\_ACK = 1 when reading.

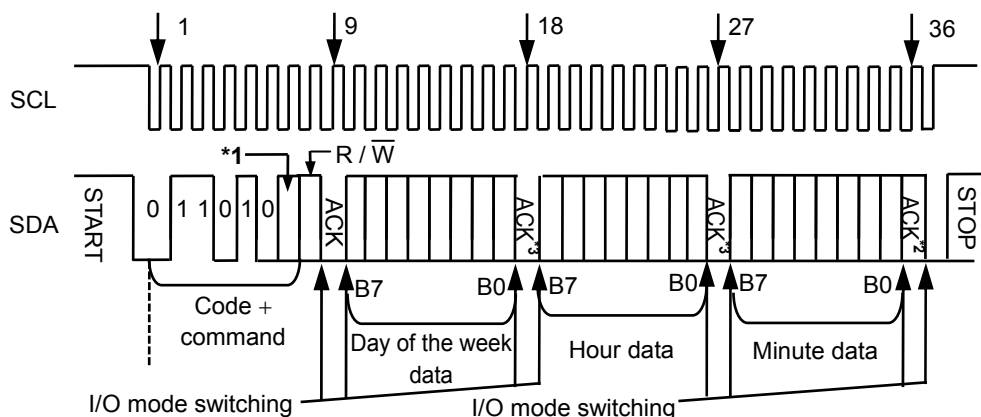
Figure 42 Status Register 1 Access and Status Register 2 Access

4.4 INT1 register access and INT2 register access

In reading / writing the INT1 and INT2 registers, data varies depending on the setting of the status register 2. Be sure to read / write after setting the status register 2. When setting the alarm by using the status register 2, these registers work as 3-byte alarm time data registers, in other statuses, they work as 1-byte registers. When outputting the user-set frequency, they are the data registers to set up the frequency.

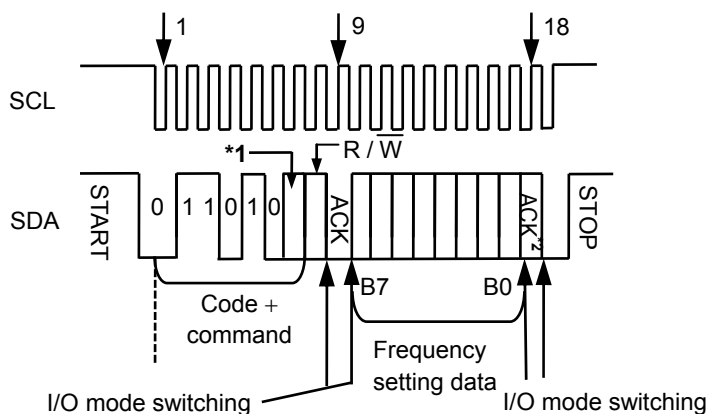
Regarding details of each data, refer to "4. INT1 register and INT2 register" in "■ Configuration of Registers".

**Caution** Users cannot use both functions of alarm 1 interrupt for the  $\overline{\text{INT1}}$  pin and  $\overline{\text{INT2}}$  pin and the output of user-set frequency simultaneously.



- \*1. 0: INT1 register selected, 1: INT2 register selected
- \*2. Set NO\_ACK = 1 when reading.
- \*3. Transmit ACK = 0 from the master device to the S-35399A03 when reading.

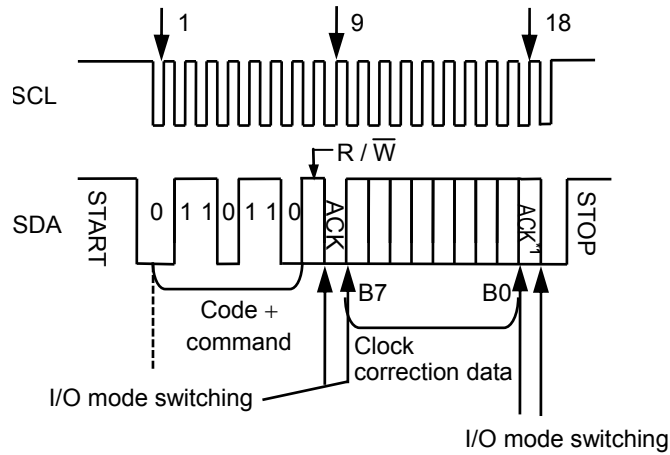
Figure 43 INT1 Register Access and INT2 Register Access



- \*1. 0: INT1 register selected, 1: INT2 register selected
- \*2. Set NO\_ACK = 1 when reading.

Figure 44 INT1 Register and INT2 Register (Data Register for Output Frequency) Access

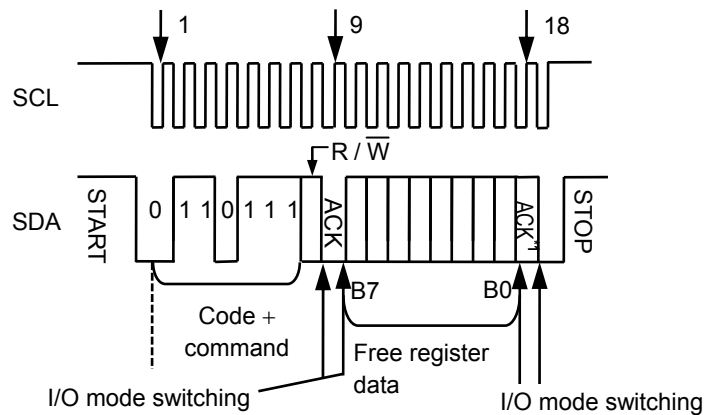
**4.5 Clock correction register access**



\*1. Set NO\_ACK = 1 when reading.

**Figure 45 Clock Correction Register Access**

**4.6 Free register 1 access**

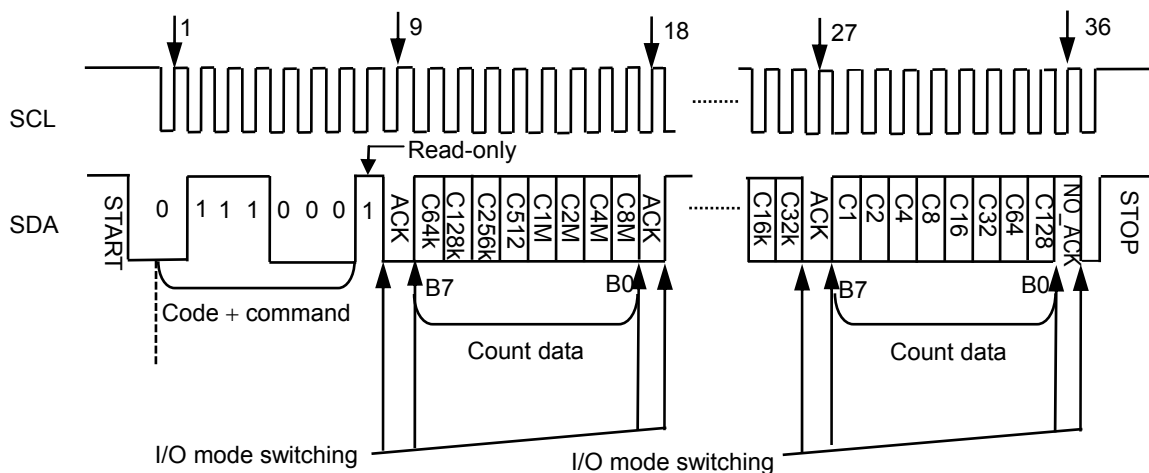


\*1. Set NO\_ACK = 1 when reading.

**Figure 46 Free Register 1 Access**

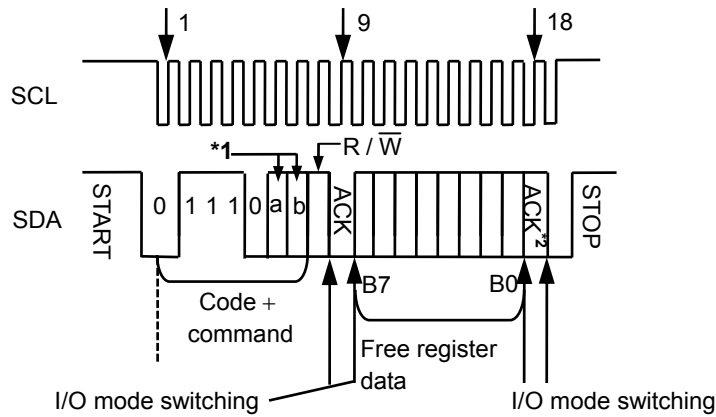
**4.7 Up counter access**

Access to the up counter is read-only. Users cannot write in this counter with write operation.



**Figure 47 Up Counter Access**

4.8 Free register 2 access and free register 3 access



\*1. To select register, use the following settings.

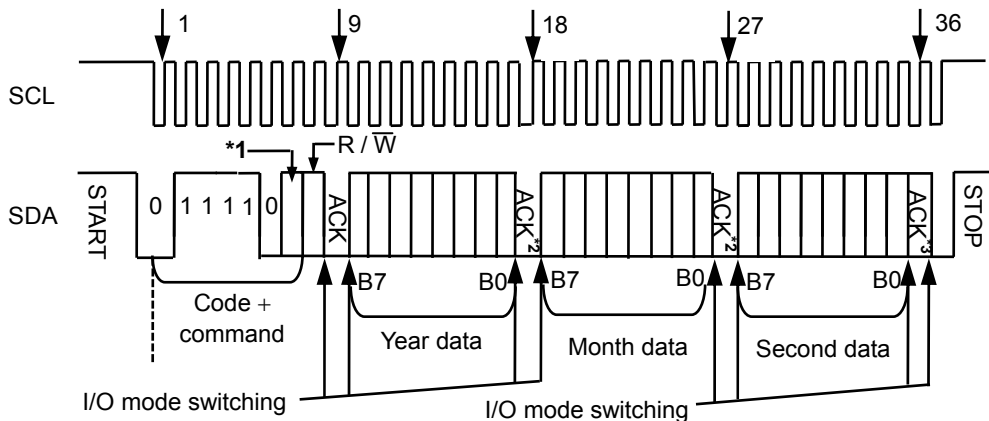
a	b	Register to Select
0	1	Free register 2
1	0	Free register 3

\*2. Set NO\_ACK = 1 when reading.

Figure 48 Free Register 2 Access and Free Register 3 Access

4.9 Alarm expansion register 1 access and alarm expansion register 2 access

Writing to the alarm expansion register 1 (alarm expansion register 2) should be executed after setting the status register 2.



\*1. 0: Alarm expansion register 1 access, 1: Alarm expansion register 2 access

\*2. Transmit ACK = 0 from the master device to the S-35399A03 when reading.

\*3. Set NO\_ACK = 1 when reading.

Figure 49 Alarm Expansion Register 1 Access and Alarm Expansion Register 2 Access

■ Reset After Communication Interruption

In case of communication interruption in the S-35399A03, for example, if the power supply voltage drops and only the master device is reset during communication, the S-35399A03 does not perform the next operation because the internal circuit keeps the status prior to communication interruption. Since the S-35399A03 does not have a reset pin, users usually reset its internal circuit by inputting a stop condition. However, if the SDA is outputting "L" (during output of acknowledgment signal or reading), the S-35399A03 does not accept a stop condition from the master device. In this case, users are necessary to finish acknowledgment output or reading of the SDA. **Figure 50** shows how to reset.

First, input a start condition from the master device (the S-35399A03 cannot detect a start condition because the SDA in the S-35399A03 is outputting "L"). Next, input a clock pulse equivalent to 1-byte data access (9-clock) from the SCL. During this period, release the SDA line for the master device. By this procedure, SDA I/O before communication interruption is finished, and the SDA line in the S-35399A03 is released. After that, inputting a stop condition resets the internal circuit and restores the regular communication. This reset procedure is recommended to be executed at initialization of the system after the master device's power supply voltage is raised.

If this reset procedure is executed when the S-35399A03 outputs an acknowledgment signal of a writing instruction, the writing operation may be performed at the corresponding register, so caution should be exercised.

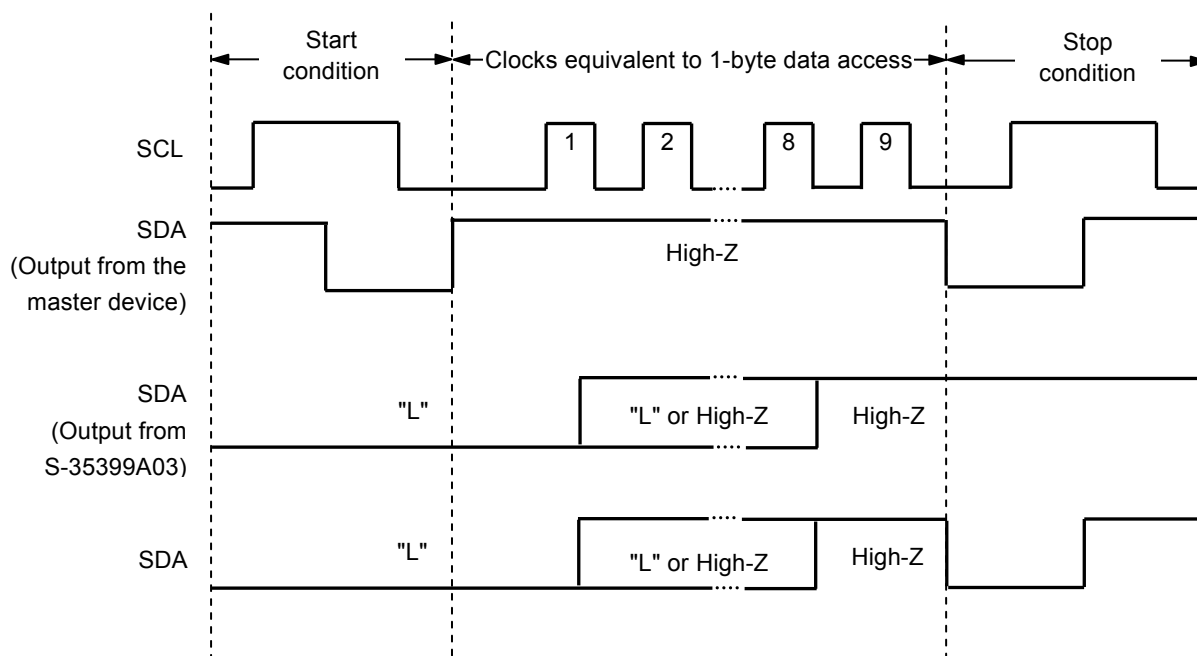
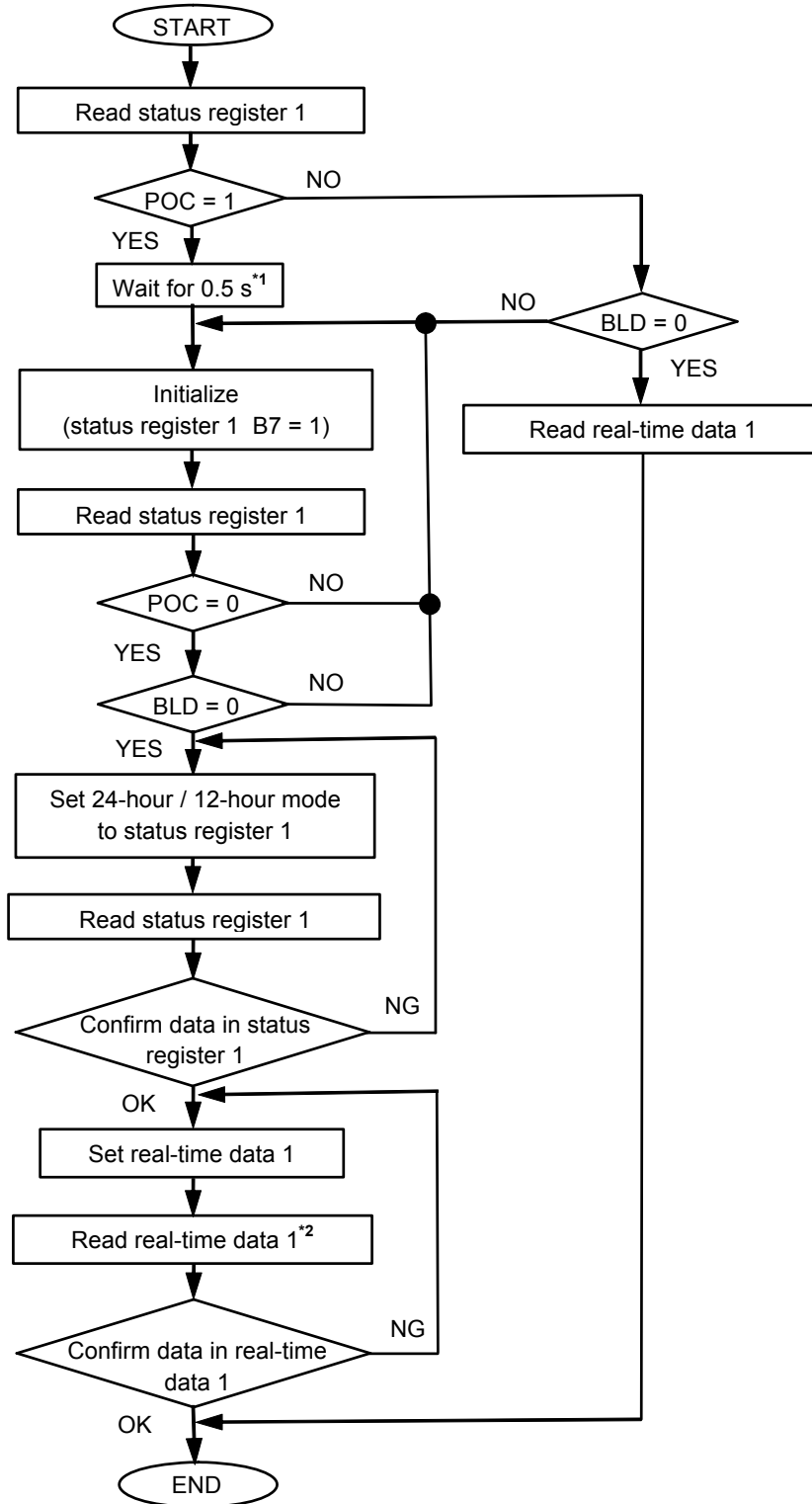


Figure 50 How to Reset

■ Flowchart of Initialization and Example of Real-time Data Set-up

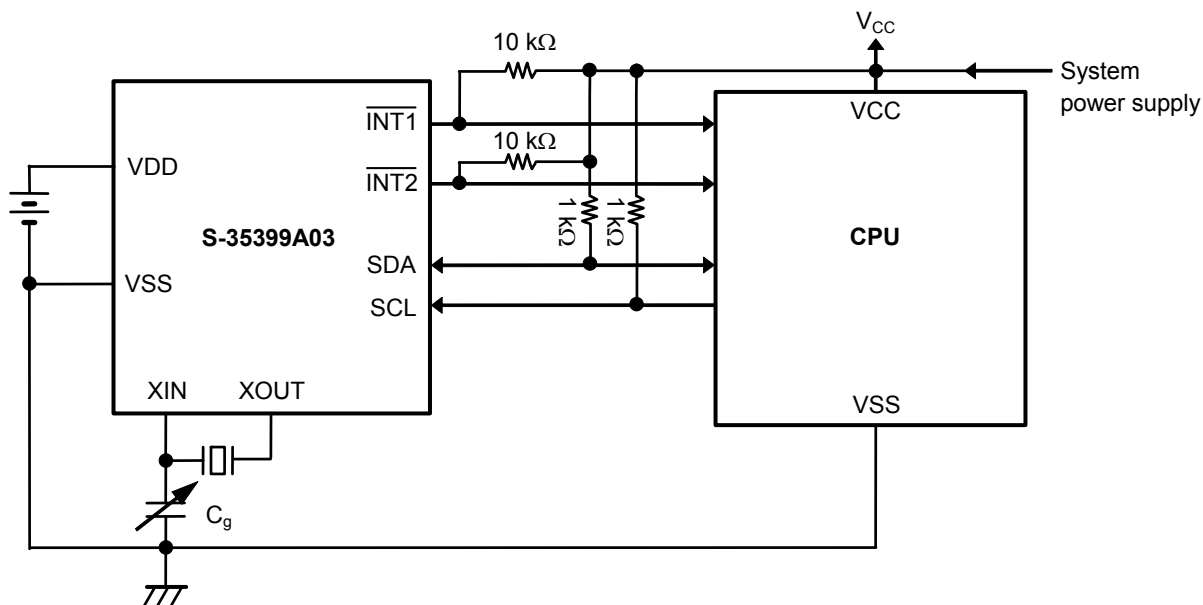
Figure 51 is a recommended flowchart when the master device shifts to a normal operation status and initiates communication with the S-35399A03. Regarding how to apply power, refer to "■ Power-on Detection Circuit and Register Status". It is unnecessary for users to comply with this flowchart of real-time data strictly. And if using the default data at initializing, it is also unnecessary to set up again.



\*1. Do not communicate for 0.5 seconds since the power-on detection circuit is in operation.  
\*2. Reading the real-time data 1 should be completed within 1 second after setting the real-time data 1.

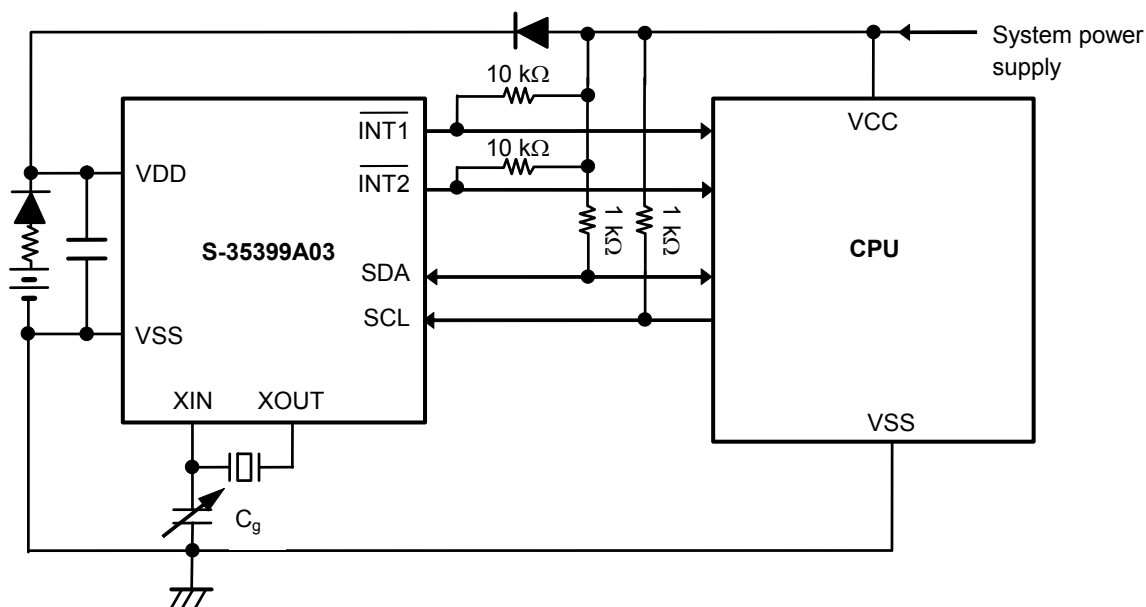
Figure 51 Example of Initialization Flowchart

■ Examples of Application Circuits



- Caution**
1. Because the I/O pin has no protective diode on the VDD side, the relation of  $V_{CC} \geq V_{DD}$  is possible. But pay careful attention to the specifications.
  2. Start communication under stable condition after power-on the power supply in the system.

Figure 52 Application Circuit 1



- Caution** Start communication under stable condition after power-on the power supply in the system.

Figure 53 Application Circuit 2

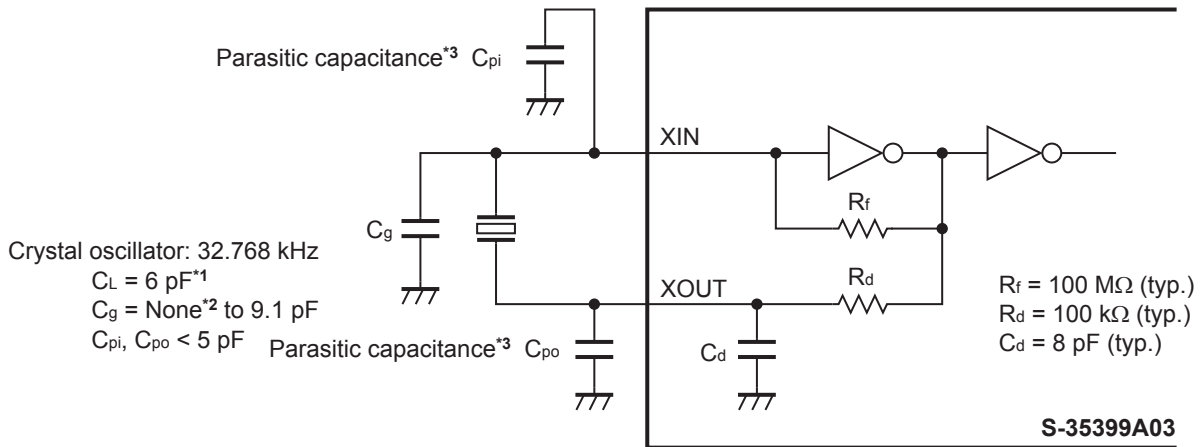
- Caution** The above connection diagrams do not guarantee operation. Set the constants after performing sufficient evaluation using the actual application.

■ Adjustment of Oscillation Frequency

1. Configuration of crystal oscillation circuit

Since the crystal oscillation circuit is sensitive to external noise (the clock accuracy is affected), the following measures are essential for optimizing the configuration.

- Place the S-35399A03, crystal oscillator, and external capacitor ( $C_g$ ) as close to each other as possible.
- Increase the insulation resistance between pins and the substrate wiring patterns of XIN and XOUT.
- Do not place any signal or power lines close to the crystal oscillation circuit.
- Locating the GND layer immediately below the crystal oscillation circuit is recommended.
- Locate the bypass capacitor adjacent to the power supply pin of the S-35399A03.



- \*1. When setting the value for the crystal oscillator's  $C_L$  as 7 pF, connect  $C_d$  externally if necessary.
- \*2. The crystal oscillation circuit operates even when  $C_g$  is not connected. Note that the oscillation frequency is in the direction that it advances.
- \*3. Design the board so that the parasitic capacitance is within 5 pF.

Figure 54 Connection Diagram 1

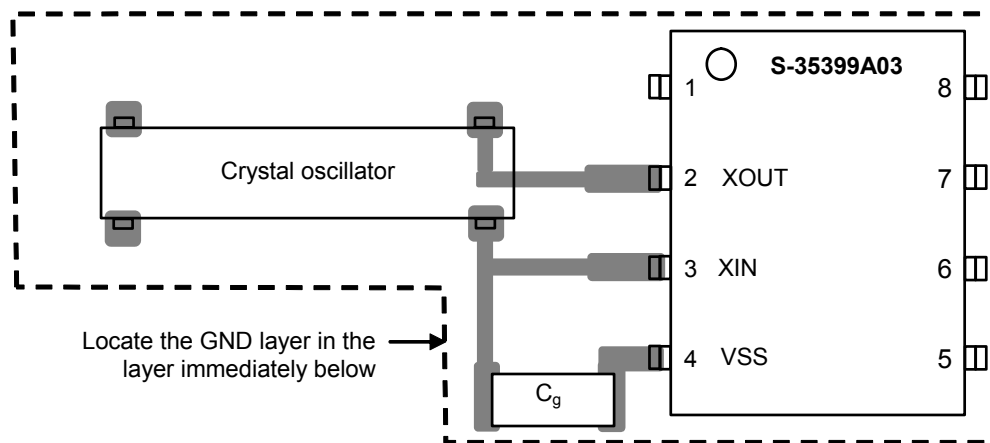


Figure 55 Connection Diagram 2

- Caution**
1. When using the crystal oscillator with a  $C_L$  exceeding the rated value (7 pF) (e.g:  $C_L = 12.5$  pF), oscillation operation may become unstable. Use a crystal oscillator with a  $C_L$  value of 6 pF or 7 pF.
  2. Oscillation characteristics is subject to the variation of each component such as substrate parasitic capacitance, parasitic resistance, crystal oscillator, and  $C_g$ . When configuring a crystal oscillaiton circuit, pay sufficient attention for them.

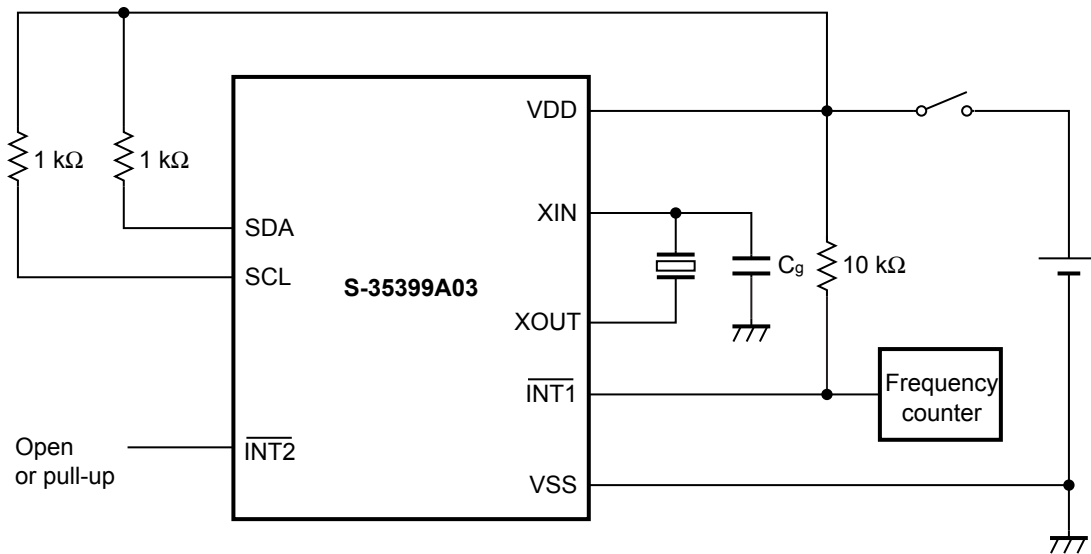
**2. Measurement of oscillation frequency**

When the S-35399A03 is turned on, the internal power-on detection circuit operates and a signal of 1 Hz is output from the  $\overline{\text{INT1}}$  pin to select the crystal oscillator and optimize the  $C_g$  value. Turn the power on and measure the signal with a frequency counter following the circuit configuration shown in **Figure 56**.

If 1 Hz signal is not output, the power-on detection circuit does not operate normally. Turn off the power and then turn it on again. For how to apply power, refer to "■ Power-on Detection Circuit and Register Status".

**Remark** If the error range is  $\pm 1$  ppm in relation to 1 Hz, the time is shifted by approximately 2.6 seconds per month (calculated using the following expression).

$$10^{-6} (1 \text{ ppm}) \times 60 \text{ seconds} \times 60 \text{ minutes} \times 24 \text{ hours} \times 30 \text{ days} = 2.592 \text{ seconds}$$



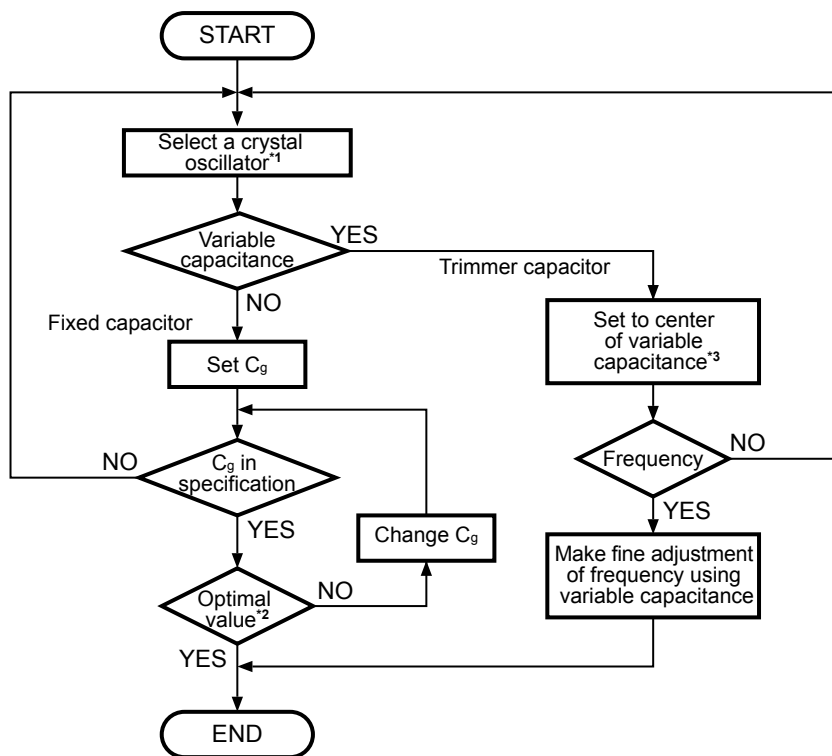
**Figure 56 Configuration of Oscillation Frequency Measurement Circuit**

- Caution**
1. Use a high-accuracy frequency counter of 7 digits or more.
  2. Measure the oscillation frequency under the use operation conditions.
  3. Since the 1 Hz signal continues to be output, initialization must be executed during normal operation.

### 3. Adjustment of oscillation frequency

#### 3.1 Adjustment by setting $C_g$

Matching of the crystal oscillator with the nominal frequency must be performed with the parasitic capacitance on the board included. Select a crystal oscillator and optimize the  $C_g$  value in accordance with the flowchart below.



\*1. Request a crystal manufacturer for a matching evaluation between the IC and the crystal oscillator. The recommended crystal characteristic values are,  $C_L$  value (load capacitance) = 6 pF,  $R_1$  value (equivalent serial resistance) = 65 k $\Omega$  max.

\*2. The  $C_g$  value must be selected on the actual PCB since it is affected by parasitic capacitance. Select the external  $C_g$  value in a range of 0 pF to 9.1 pF.

\*3. Adjust the rotation angle of the variable capacitance so that the capacitance value is slightly smaller than the center, and confirm the oscillation frequency and the center value of the variable capacitance. This is done in order to make the capacitance of the center value smaller than one half of the actual capacitance value because a smaller capacitance value increases the frequency variation.

Figure 57 Crystal Oscillator Setting Flow

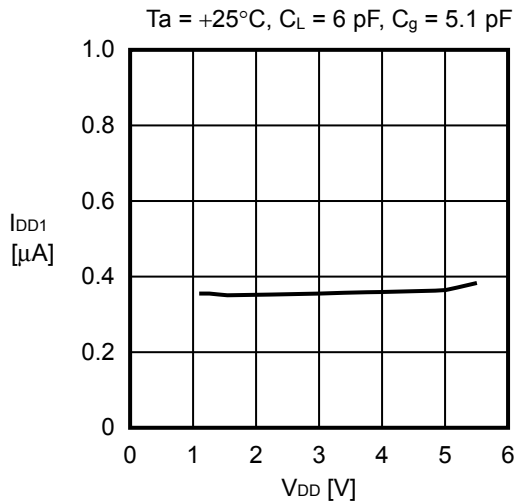
- Caution**
1. The oscillation frequency varies depending on the ambient temperature and power supply voltage. Refer to "■ Characteristics (Typical Data)".
  2. The 32.768 kHz crystal oscillator operates more slowly at an operating temperature higher or lower than +20°C to +25°C. Therefore, it is recommended to set the oscillator to operate slightly faster at normal temperature.

■ **Precautions**

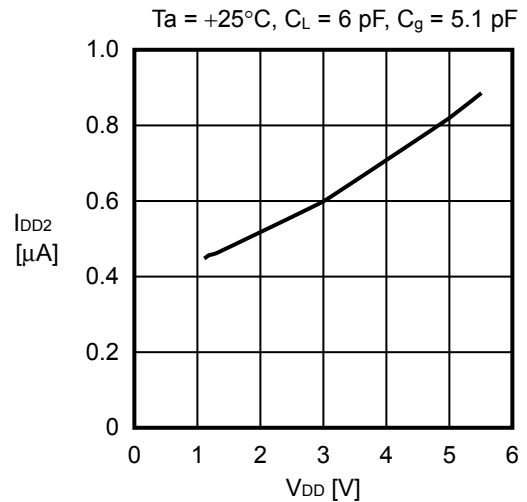
- Do not apply an electrostatic discharge to this IC that exceeds the performance ratings of the built-in electrostatic protection circuit.
- ABLIC Inc. claims no responsibility for any disputes arising out of or in connection with any infringement by products including this IC of patents owned by a third party.

■ Characteristics (Typical Data)

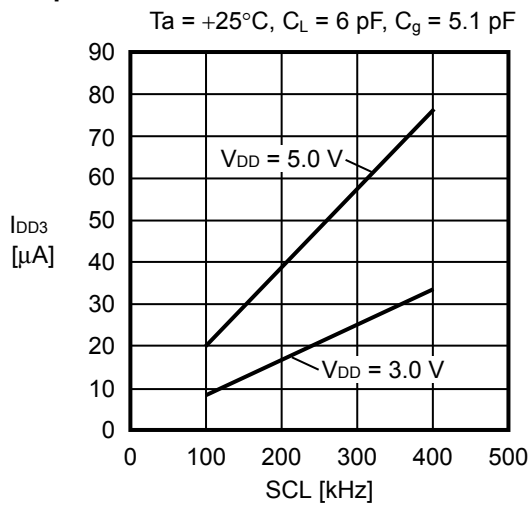
1. Current consumption 1 (current consumption out of communication) vs.  $V_{DD}$  characteristics



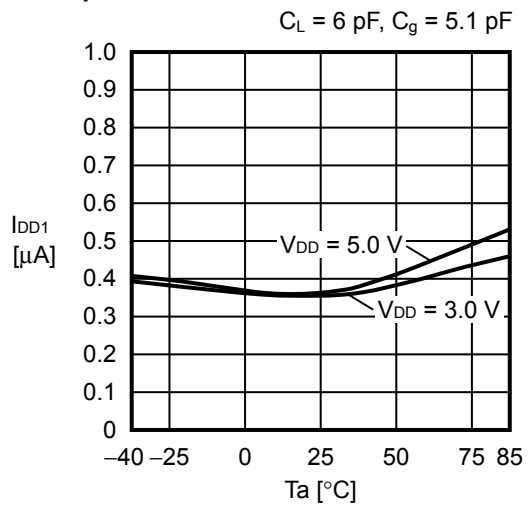
2. Current consumption 2 (current consumption when 32.768 kHz is output) vs.  $V_{DD}$  characteristics



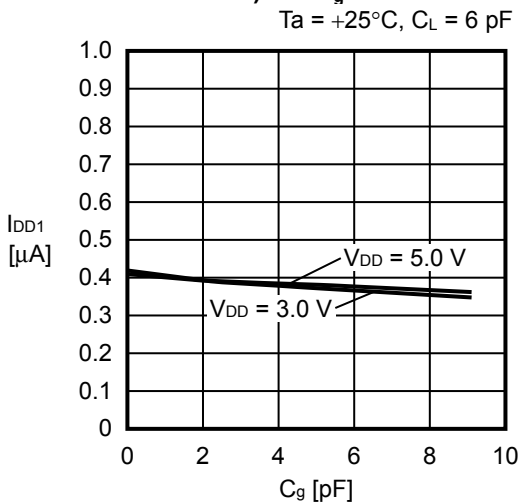
3. Current consumption 3 (current consumption during communication) vs. Input clock characteristics



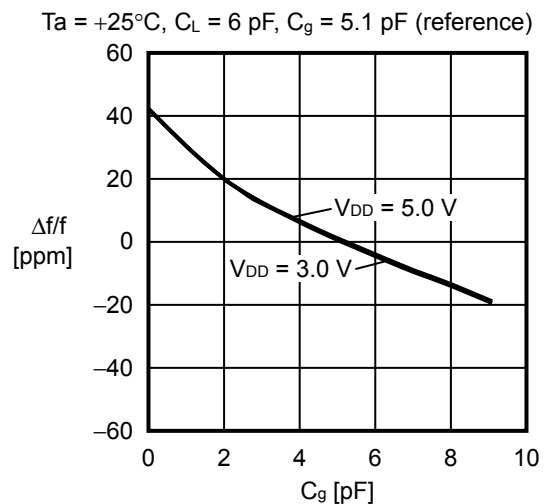
4. Current consumption 1 (current consumption out of communication) vs. Temperature characteristics



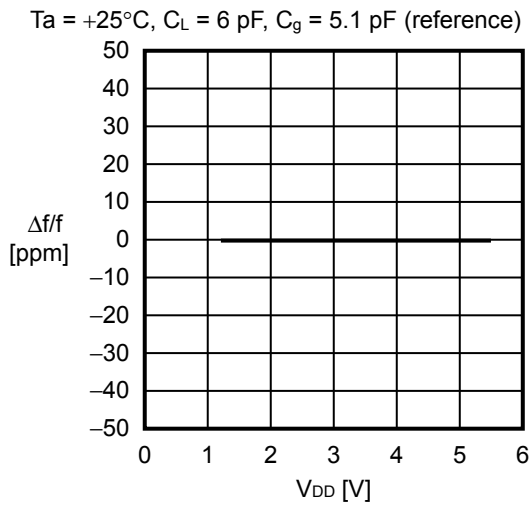
5. Current consumption 1 (current consumption out of communication) vs.  $C_g$  characteristics



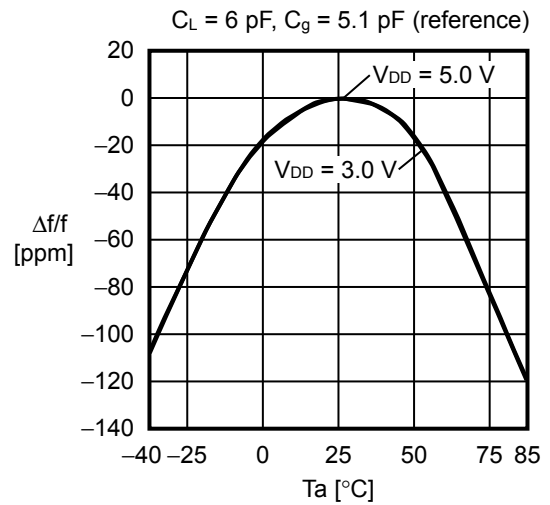
6. Oscillation frequency vs.  $C_g$  characteristics



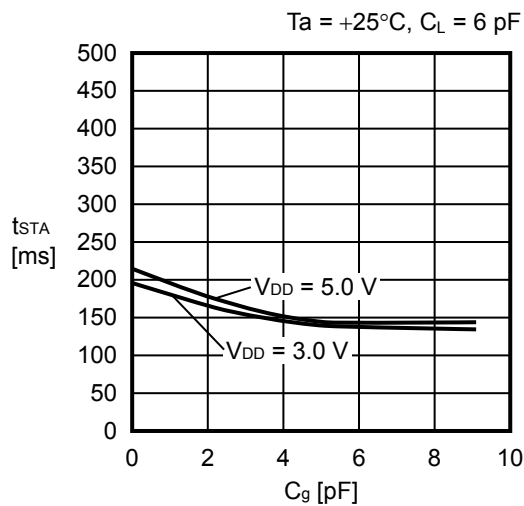
**7. Oscillation frequency vs.  $V_{DD}$  characteristics**



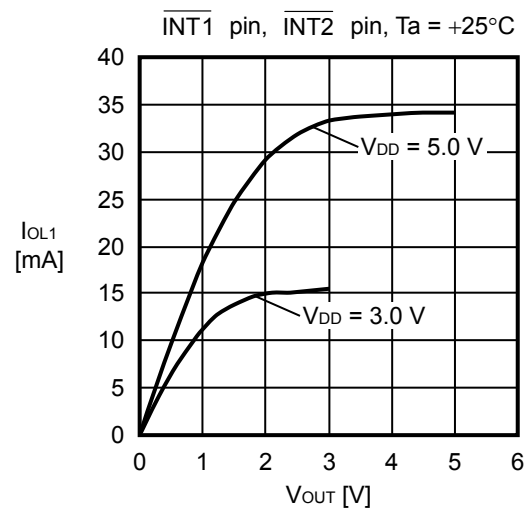
**8. Oscillation frequency vs. Temperature characteristics**



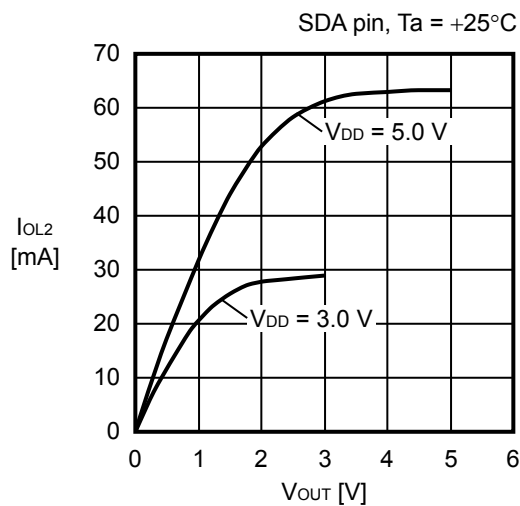
**9. Oscillation start time vs. Temperature characteristics (XOUT pin monitor)**



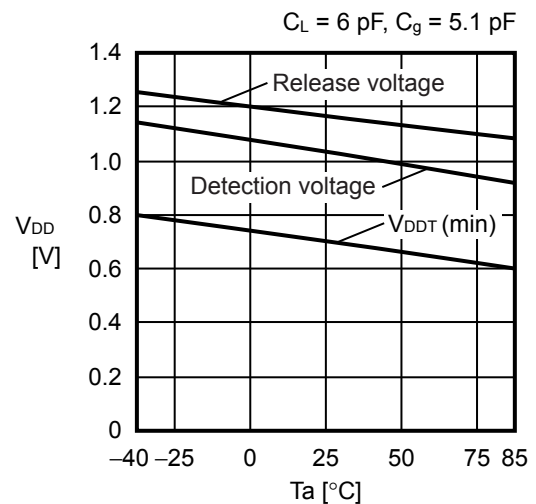
**10. Output current characteristics 1 ( $V_{OUT}$  vs.  $I_{OL1}$ )**



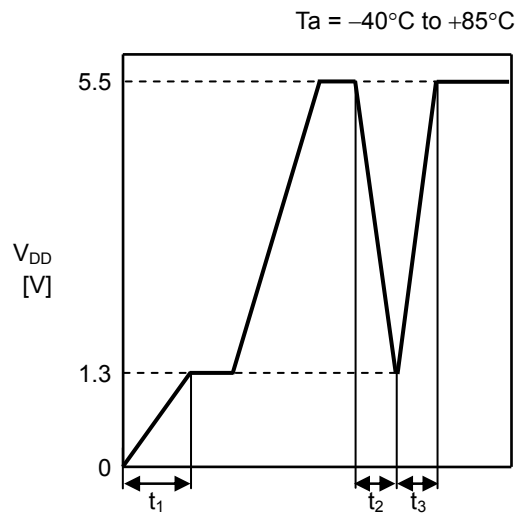
**11. Output current characteristics 2 ( $V_{OUT}$  vs.  $I_{OL2}$ )**



**12. Low power supply voltage detection voltage, release voltage, and time keeping power supply voltage (min) vs. Temperature characteristics**



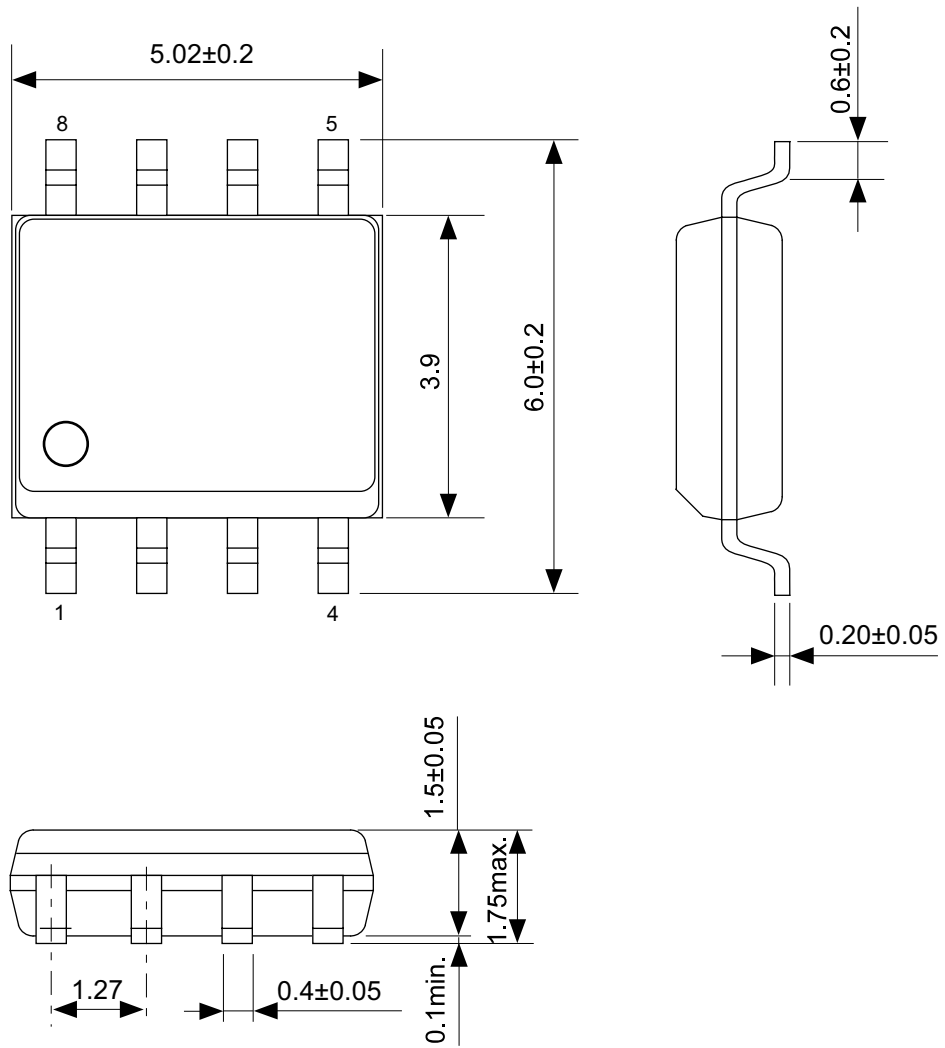
### 13. Characteristics of power-on detection circuit




$t_1$ : A condition that power-on detection works at turning on  
 $t_1 \leq 10 \text{ ms}$

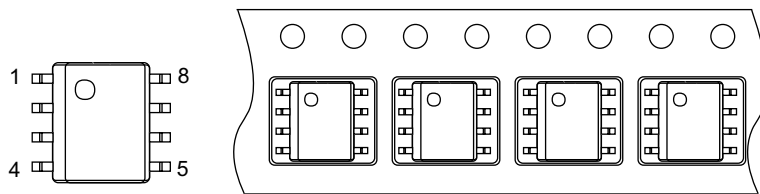
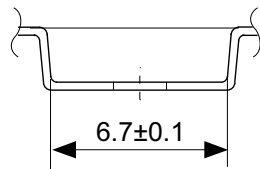
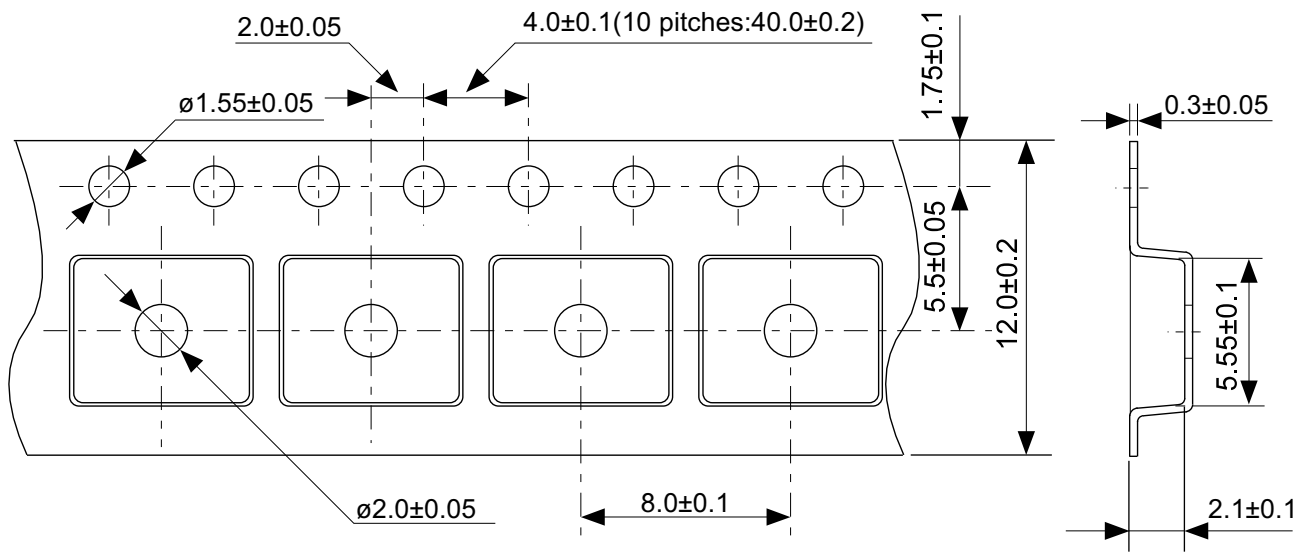
$t_2$ : A condition that the IC works regularly and data is retained during power voltage drop  
 $t_2 \geq 1 \text{ ms}$

$t_3$ : A condition that the IC works regularly and data is retained during power voltage rise  
 $t_3 \geq 1 \text{ ms}$



No. FJ008-A-P-SD-2.2

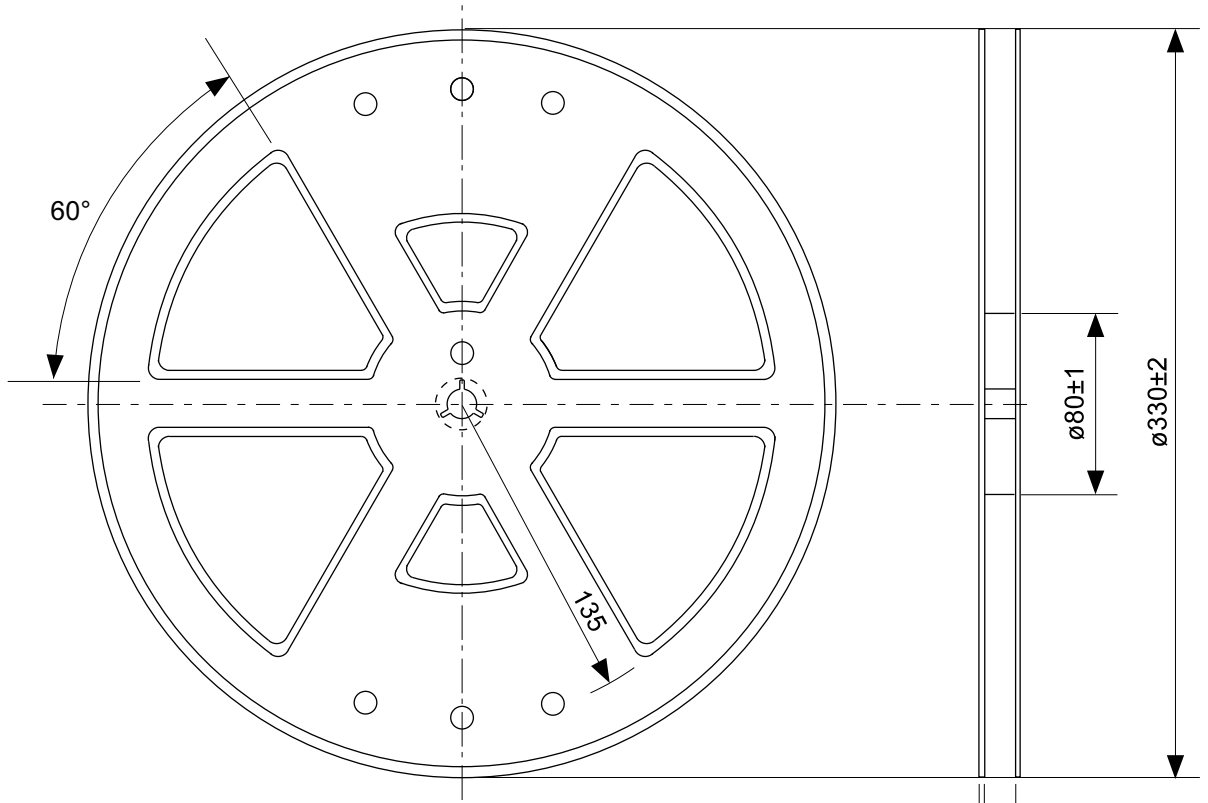
TITLE	SOP8J-D-PKG Dimensions
No.	FJ008-A-P-SD-2.2
ANGLE	
UNIT	mm
<b>ABLIC Inc.</b>	



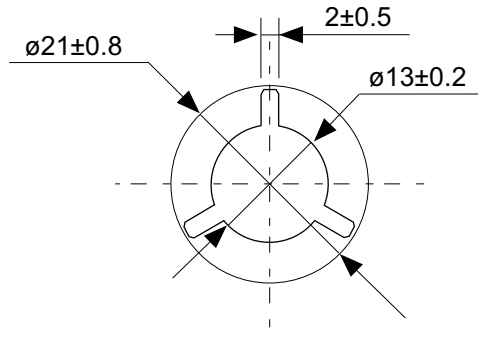
→  
Feed direction

No. FJ008-D-C-SD-1.1

TITLE	SOP8J-D-Carrier Tape
No.	FJ008-D-C-SD-1.1
ANGLE	
UNIT	mm
<b>ABLIC Inc.</b>	

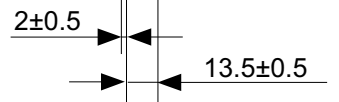
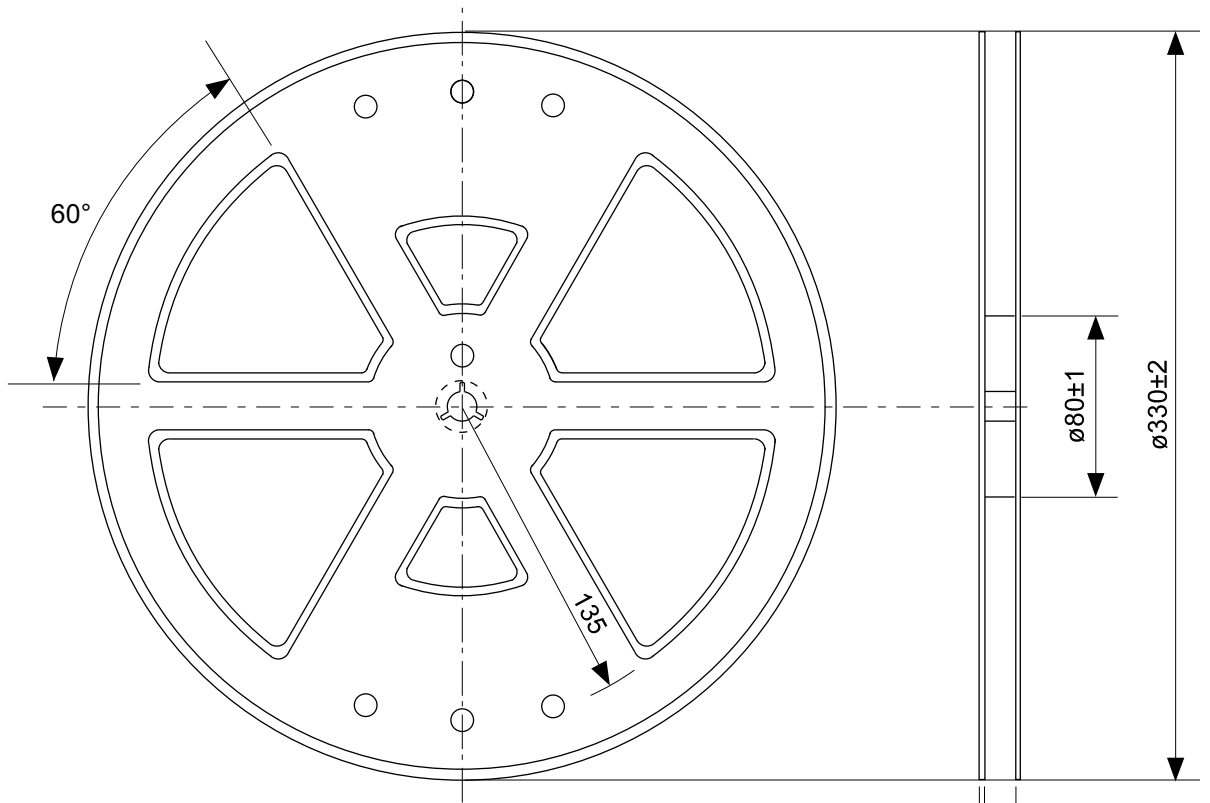


Enlarged drawing in the central part

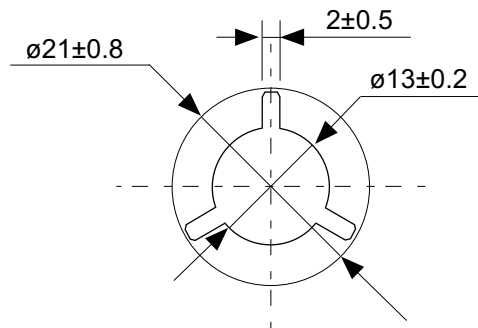


No. FJ008-D-R-SD-1.1

TITLE	SOP8J-D-Reel		
No.	FJ008-D-R-SD-1.1		
ANGLE		QTY.	2,000
UNIT	mm		
<b>ABLIC Inc.</b>			



Enlarged drawing in the central part



No. FJ008-D-R-S1-1.0

TITLE	SOP8J-D-Reel		
No.	FJ008-D-R-S1-1.0		
ANGLE		QTY.	4,000
UNIT	mm		
<b>ABLIC Inc.</b>			

## Disclaimers (Handling Precautions)

1. All the information described herein (product data, specifications, figures, tables, programs, algorithms and application circuit examples, etc.) is current as of publishing date of this document and is subject to change without notice.
2. The circuit examples and the usages described herein are for reference only, and do not guarantee the success of any specific mass-production design.  
ABLIC Inc. is not responsible for damages caused by the reasons other than the products described herein (hereinafter "the products") or infringement of third-party intellectual property right and any other right due to the use of the information described herein.
3. ABLIC Inc. is not responsible for damages caused by the incorrect information described herein.
4. Be careful to use the products within their specified ranges. Pay special attention to the absolute maximum ratings, operation voltage range and electrical characteristics, etc.  
ABLIC Inc. is not responsible for damages caused by failures and / or accidents, etc. that occur due to the use of the products outside their specified ranges.
5. When using the products, confirm their applications, and the laws and regulations of the region or country where they are used and verify suitability, safety and other factors for the intended use.
6. When exporting the products, comply with the Foreign Exchange and Foreign Trade Act and all other export-related laws, and follow the required procedures.
7. The products must not be used or provided (exported) for the purposes of the development of weapons of mass destruction or military use. ABLIC Inc. is not responsible for any provision (export) to those whose purpose is to develop, manufacture, use or store nuclear, biological or chemical weapons, missiles, or other military use.
8. The products are not designed to be used as part of any device or equipment that may affect the human body, human life, or assets (such as medical equipment, disaster prevention systems, security systems, combustion control systems, infrastructure control systems, vehicle equipment, traffic systems, in-vehicle equipment, aviation equipment, aerospace equipment, and nuclear-related equipment), excluding when specified for in-vehicle use or other uses. Do not apply the products to the above listed devices and equipments without prior written permission by ABLIC Inc. Especially, the products cannot be used for life support devices, devices implanted in the human body and devices that directly affect human life, etc.  
Prior consultation with our sales office is required when considering the above uses.  
ABLIC Inc. is not responsible for damages caused by unauthorized or unspecified use of our products.
9. Semiconductor products may fail or malfunction with some probability.  
The user of the products should therefore take responsibility to give thorough consideration to safety design including redundancy, fire spread prevention measures, and malfunction prevention to prevent accidents causing injury or death, fires and social damage, etc. that may ensue from the products' failure or malfunction.  
The entire system must be sufficiently evaluated and applied on customer's own responsibility.
10. The products are not designed to be radiation-proof. The necessary radiation measures should be taken in the product design by the customer depending on the intended use.
11. The products do not affect human health under normal use. However, they contain chemical substances and heavy metals and should therefore not be put in the mouth. The fracture surfaces of wafers and chips may be sharp. Be careful when handling these with the bare hands to prevent injuries, etc.
12. When disposing of the products, comply with the laws and ordinances of the country or region where they are used.
13. The information described herein contains copyright information and know-how of ABLIC Inc.  
The information described herein does not convey any license under any intellectual property rights or any other rights belonging to ABLIC Inc. or a third party. Reproduction or copying of the information from this document or any part of this document described herein for the purpose of disclosing it to a third-party without the express permission of ABLIC Inc. is strictly prohibited.
14. For more details on the information described herein, contact our sales office.

2.0-2018.01