

# ALD-514012PJ134

DC-DC Converter for LC Panels  
with LED Backlights

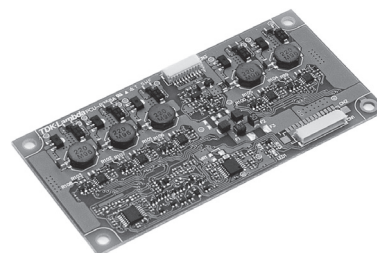

## ■ Features

- Five Outputs
- Low profile and compact
- High efficiency
- Usable in a wide range of temperatures
- Applicable panel size: 10 to 19 inches (rough guide)
- Combined use of PWM modulated light and analog modulated light (ADIM) assures universality
- Equipped with load (LED) open detection (alarm output) function

## ■ Applications



## ALD-514012PJ134 Specifications (Please refer to each specification before use)

### Electrical Characteristics

Item	Unit	Symbol	Specification			Condition					Remarks	
			min	typ	max	Vin(V)	Vrmt(V)	Vbr(V)	ADIM(V)	Ta(°C)		RL1,2(Ω)
Output Current	mA	Iout1-5 (Maximum dimmer)	112	140	168	12±0.1	3±0.05	0	0	25±10	180	(*1)
			100	140	180	12±1.2				-30 to 85		(*1)
		Iout1-5 (when modulating light)	10	20	30	12±0.1	3±0.05	2.5	0	25±10	180	PWM modulated light (*1)(*2)
			4	20	40	12±0.1	3±0.05	0	2.5	25±10	870	ADIM modulated light (*1)(*2)
Input Current	A	Iin1	1.20	1.64	2.00	12±0.1	3±0.05	0	0	25±10	180	Remote ON
			1.00	1.64	2.50	12±1.2				-30 to 85		
	mA	Iin2	-	-	1	12±0.1	0	0	0	25±10	180	Remote OFF
Modulated light frequency	Hz	F	160	200	240	12±0.1	3±0.05	2.5	0	25±10	180	
Alarm Signal	V	Vst	-	0.1	0.5	12±0.1	3±0.05	0	0	25±10	180	On a normal operation (*3)
			4.75	5	5.25	12±0.1						3±0.05

### Other Specifications

Modulated light system		PWM/ADIM (*2)
Operating Temperature	°C	-30 to +85
Storage Temperature	°C	-40 to +85
Operating Humidity Ratio	RH%	95Max
Weight	g	22 max.
Dimensions (WxDxH)	mm	100x50.0x5.2 (*4)
Fused Input		Yes
Remote ON / OFF		Yes
Lamp open detection function		Yes

## ■ Conformity to RoHs Directive

This means that, in conformity with EU Directive 2002/95/EC, lead, cadmium, mercury, hexavalent chromium, and specific bromine-based flame retardants, PBB and PBDE, have not been used, except for exempted applications.

(\*1) When output is open, the output voltage of that series is restricted, and other series operate normally.

(\*2) See "Connections" as well as "Analog Modulation Light (ADIM) and PWM Modulation Light" for details about modulation light.

(\*3) See "Connections" for details about alarm output.

(\*4) These dimensions are indicated the maximum only H. Others are typical values.

# Outline Drawing

Plan View (components surface)

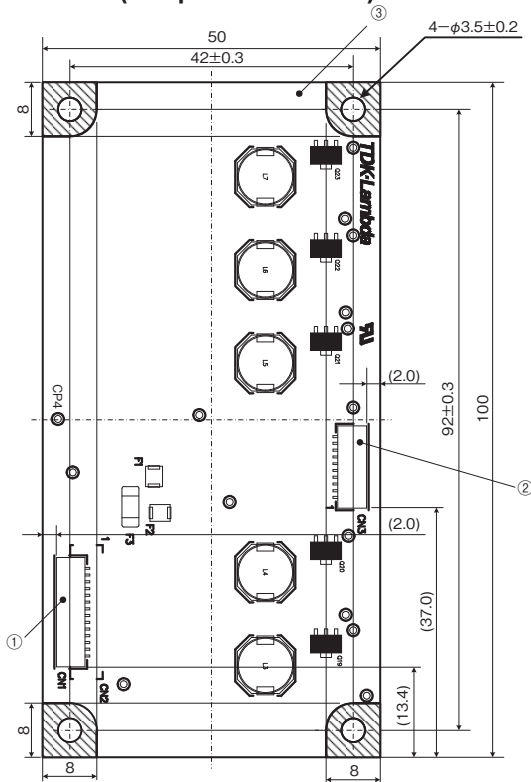

Side View



Bottom View

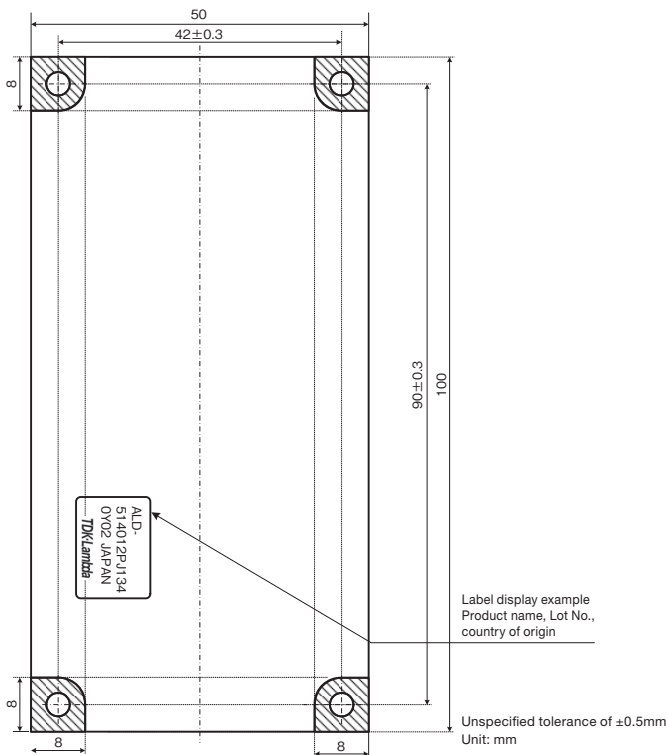

Component and pattern prohibited area (GND line excluded)

When securing LED driver, check to make sure crowns and plates (including uneven parts) fit inside the above prohibited areas (diagonal lined areas).

## Connector

No.	Component name	Type name	Qty	Remarks	Recommended suitable connector
①	Input connector CN1	SM14B-SRSS-TB (LF)(SN)	1	J.S.T Mfg., Co., Ltd	SHR-14V-S-B
②	Output connector CN3	SM10B-SRSS-TB (LF)(SN)	1	J.S.T Mfg., Co., Ltd	SHR-10V-S-B
③	Printed circuit board PCB	Glass epoxy (FR-4)	1	UL94V-0 t =1.0mm	—

※Not equipped with CN2.

## Connector Terminal and Number Functions

※Input connector CN2 is not mounted.

### Input side CN1

Terminal No.	Symbol	Rating	Remarks
CN1-1	Vin	12±1.2V	Power source input
CN1-2			
CN1-3			
CN1-4			
CN1-5			
CN1-6	GND	0V	Ground
CN1-7			
CN1-8			
CN1-9			
CN1-10	Vrmt	0-0.4(V) or OPEN/2.5-Vin(V)	OFF / ON
CN1-11			
CN1-12	Vbr /Rbr	2.5(V)/0(V) 50(kΩ)/0(kΩ)	PWM modulated light MIN/MAX Modulated light function using output PWM modulation
CN1-13	ADIM	2.5(V)/0(V)	ADIM modulated light MIN/MAX Modulated light function using output current variation
CN1-14	Vst	0(V)/5.0(V)	At time of normal load/ at time of abnormal load

### Output side CN3

Terminal No.	Symbol	Remarks
CN3-1	LED_C5	Series5-cathode side
CN3-2	LED_A5	Series5-anode side
CN3-3	LED_A4	Series 4 - anode side
CN3-4	LED_C4	Series 4 - cathode side
CN3-5	LED_C3	Series 3 - cathode side
CN3-6	LED_A3	Series 3 - anode side
CN3-7	LED_A2	Series 2 - anode side
CN3-8	LED_C2	Series 2 - cathode side
CN3-9	LED_C1	Series 1 - cathode side
CN3-10	LED_A1	Series 1 - anode side

# Connections

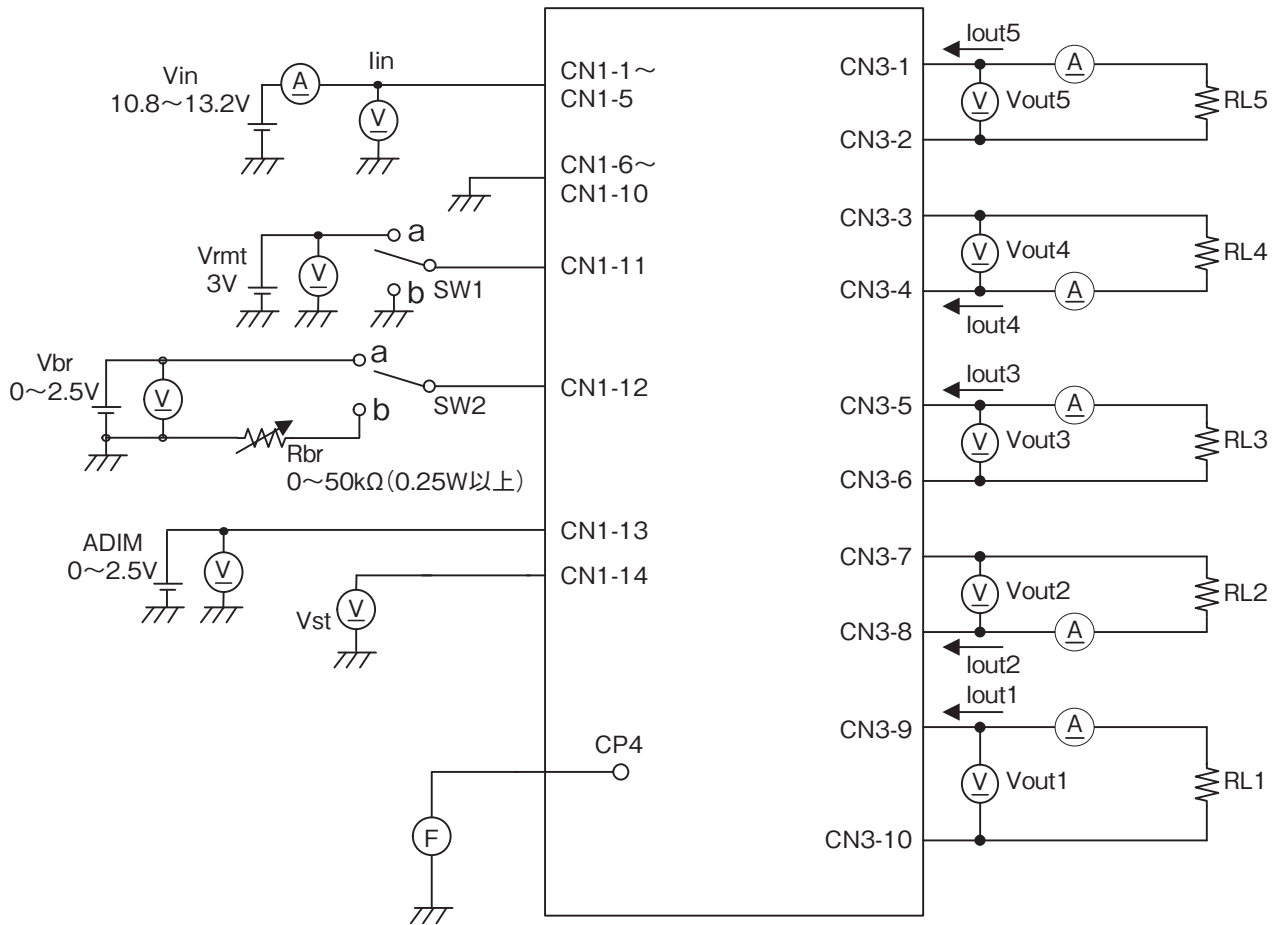

RL1 to 4: Load resistance (15W min.)

Operate by ON-OFF of SW1 as follows.

SW1	Unit operates
a	Operates
b	Does not operate
Open	Does not operate

Operate as follows by switching a SW2.

SW2	Unit operates
a	Voltage dimmer Vbr=0 to 2.5V (0V : Maximum brightness)
b	Volume dimmer VR=0 to 50kΩ (0Ω : Maximum brightness)

### Measuring Instruments

- (V) : DC voltmeter (ADVANTEST R6452A equivalent)
- (A) : DC ammeter (ADVANTEST R6452A equivalent)
- (F) : Frequency counter (ADVANTEST R6452A equivalent)

### Protection Circuit Operation

Load condition	Alarm output (CN1-14)	With or without latch
Stationary	0.5V max.	No latch
1 output open	4.5V min.	No latch
All outputs open	4.5V min.	No latch

Alarm output Vst may be output when there is excessive ON/OFF of Vin and Vrms.

## Analog Modulated Light (ADIM) and PWM Modulated Light Combination Example

Determines maximum value for output current in analog modulated light, to enable brightness control at that range, using PWM modulated light.

<Modulated Light Example 1 (gray in diagram below)>

Set output current value to 100%, in cases where PWM modulated light is desired at a modulated light range of 100% to 0%

<Modulated Light Example 2 (black in diagram below)>

Set output current value to 50%, in cases where PWM modulated light is desired at a modulated light range of 100% to 0%

PWM Modulated Light Voltage and Output Current Examples

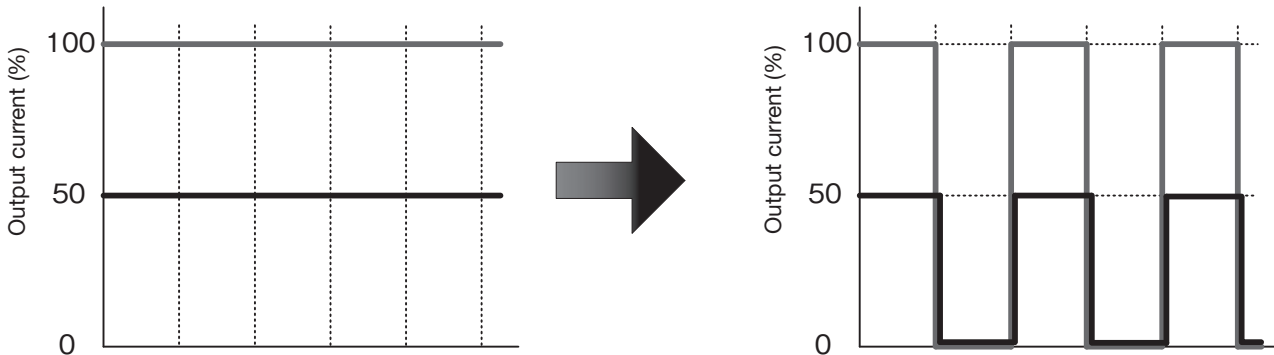

Analog modulated light is the modulated light system for changing current amplitude. The benefits this system offer are that low frequency noise hardly occurs because it does not have an intermittent action and input power source load is small because input current variation is small. Conversely, because it changes the LED action point, chromaticity varies according to the modulated light.

PWM modulated light is the system where intermittent actions are made at low frequency in the range of 100kHz to 1kHz, and this on duty is varied to modulate light. Although this system leaves concern about low frequency noise and the demand for excessive answering to accommodate input power source, it offers the benefit of small chromaticity variations according to the modulated light because the LED action point does not change. PWM modulated light comes in two forms: a built-in PWM modulated light system (this is inside the LED driver generating chopping and sawtooth waves, which are compared against the external DC voltage to form a modulated light pulse) and an external PWM modulated light system (this directly applies the pulse from outside to modulate light).

The ALD Series combines analog modulated light and PWM modulated light to enable the generation of modulated light that suits your needs.