

System-Side Impedance Track™ Fuel Gauge With Integrated Sense Resistor

FEATURES

- **Battery Fuel Gauge for 1-Series LiCoO₂ battery Applications**
- **Easy to Configure Battery Fuel Gauging Based on Patented Impedance Track™ Technology**
 - **Models Battery Discharge Curve for Accurate State-of-Charge Report**
 - **Automatically Adjusts for Battery Aging, Battery Self-Discharge, and Temperature/Rate Inefficiencies**
 - **Low-Value Integrated Sense Resistor (10 mΩ typical)**
- **Resides on System Main Board**
 - **Works with Embedded or Removable Battery Packs**
 - **Integrated LDO allows devices to be powered directly from battery pack**
- **Microcontroller Peripheral Provides:**
 - **Accurate Battery Fuel Gauging**
 - **Internal Temperature Sensor for Battery Temperature Reporting**
 - **Configurable Level of State-of-Charge (SOC) Interrupts**
- **I²C™ for Connection to System Microcontroller Port**
- **Small 15-pin 2,69 × 1,75 mm, 0.5 mm pitch CSP package**

APPLICATIONS

- **Feature Phones**
- **Smart Phones**
- **PDA's**
- **Digital Still and Video Cameras**
- **Handheld Terminals**
- **MP3 or Multimedia Players**

DESCRIPTION

The Texas Instruments bq27425 system-side LiCoO₂ battery fuel gauge is an easy to configure microcontroller peripheral that provides fuel gauging for single-cell LiCoO₂ battery packs. The device requires minimal user configurations and system microcontroller firmware development for accurate fuel gauging.

The bq27425 uses the patented Impedance Track™ algorithm for fuel gauging, and provides information such as remaining battery capacity (mAh), state-of-charge (%), and battery voltage (mV).

Battery fuel gauging with the bq27425 requires only PACK+ (P+), PACK- (P-), for a removable battery pack or embedded battery circuit. The 15-pin 2,69 × 1,75 mm, 0.5 mm pitch CSP package is ideal for space constrained applications.

TYPICAL APPLICATION

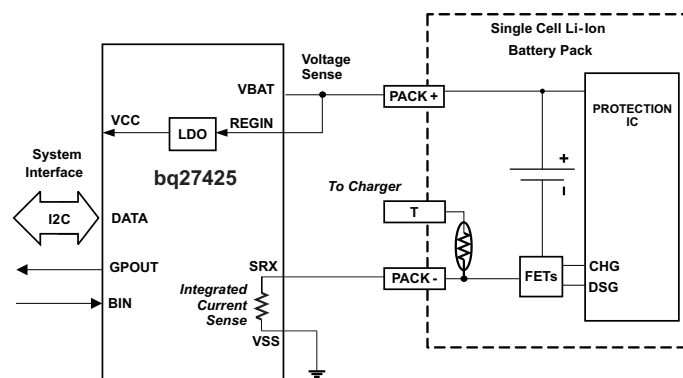

Please be aware that an important notice concerning availability, standard warranty, and use in critical applications of Texas Instruments semiconductor products and disclaimers thereto appears at the end of this data sheet.

Impedance Track is a trademark of Texas Instruments.

I²C is a trademark of Phillips Corporation.



These devices have limited built-in ESD protection. The leads should be shorted together or the device placed in conductive foam during storage or handling to prevent electrostatic damage to the MOS gates.

DEVICE INFORMATION

AVAILABLE OPTIONS

PART NUMBER	PACKAGE ⁽¹⁾	T _A	COMMUNICATION FORMAT	TAPE and REEL QUANTITY
bq27425YZFR-G1	CSP-15	-40°C to 85°C	I ² C	3000
bq27425YZFT-G1				250

(1) For the most current package and ordering information see the Package Option Addendum at the end of this document; or, see the TI website at www.ti.com.

PIN DIAGRAM

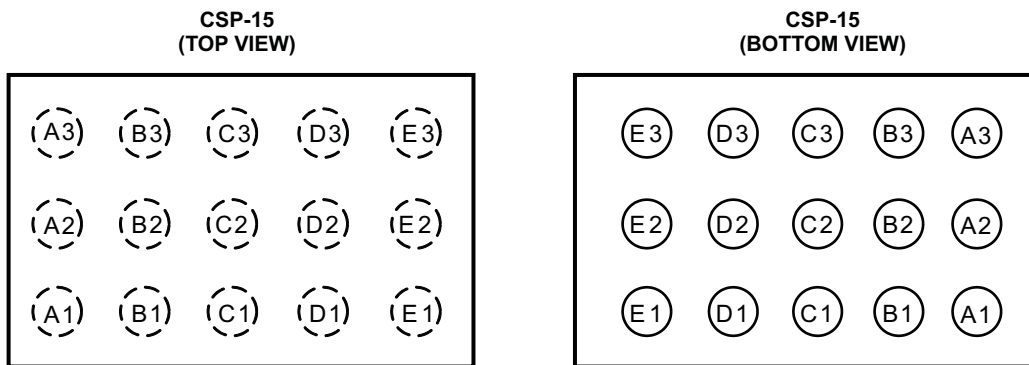

PIN FUNCTIONS

PIN		TYPE ⁽¹⁾	DESCRIPTION
NAME	NO.		
SRX	B1	IA	Integrated Sense Resistor and Coulomb Counter input typically connected to battery PACK- terminal. For best performance decouple with 0.1µF ceramic capacitor to V _{SS} .
V _{SS}	C1	P, IA	Device ground and Integrated Sense Resistor termination.
V _{CC}	D1	P	Regulator output and bq27425 processor power. Decouple with 1µF ceramic capacitor to V _{SS} .
REGIN	E1	P	Regulator input. Decouple with 0.1µF ceramic capacitor to V _{SS} .
CE	D2	I	Chip Enable. Internal LDO is disconnected from REGIN when driven low.
BAT	E2	I	Cell-voltage measurement input. ADC input. Recommend 4.8V maximum for conversion accuracy.
SCL	A3	I	Slave I ² C serial communications clock input line for communication with system (Master). Use with 10kΩ pull-up resistor (typical).
SDA	B3	I/O	Slave I ² C serial communications data line for communication with system (Master). Open-drain I/O. Use with 10kΩ pull-up resistor (typical).
BIN	C3	I	Battery-insertion detection input. A logic high to low transition is detected as a battery insertion event. Recommend using a pull-up resistor >1MΩ (1.8 MΩ typical) to V _{CC} for reduced power consumption. An internal pull-up resistor option is also available using the Operation Configuration [BI_PU_EN] register bit.
GPOUT	A2	O	General Purpose open-drain output. May be configured as a Battery Low indicator or perform SOC interrupt (SOC_INT) function.
NC	A1, B2, C2, D3, E3	IA	No Connect.

(1) I/O = Digital input/output, IA = Analog input, P = Power connection

ELECTRICAL SPECIFICATIONS

ABSOLUTE MAXIMUM RATINGS

over operating free-air temperature range (unless otherwise noted)⁽¹⁾

PARAMETER		VALUE	UNIT
V _{REGIN}	Regulator input range	-0.3 to 5.5	V
V _{CC}	Supply voltage range	-0.3 to 2.75	V
V _{IOD}	Open-drain I/O pins (SDA, SCL)	-0.3 to 5.5	V
V _{BAT}	BAT input pin	-0.3 to 5.5	
V _I	Input voltage range to all other pins (SRX , GPOUT)	-0.3 to V _{CC} + 0.3	V
T _A	Operating free-air temperature range	-40 to 85	°C
T _{stg}	Storage temperature range	-65 to 150	°C

- (1) Stresses beyond those listed under "absolute maximum ratings" may cause permanent damage to the device. These are stress ratings only, and functional operation of the device at these or any other conditions beyond those indicated under "recommended operating conditions" is not implied. Exposure to absolute-maximum-rated conditions for extended periods may affect device reliability.

THERMAL INFORMATION

THERMAL METRIC ⁽¹⁾		Value	UNITS
		YZF(15 PINS)	
θ _{JA}	Junction-to-ambient thermal resistance	70	°C/W
θ _{JCtop}	Junction-to-case (top) thermal resistance	17	
θ _{JB}	Junction-to-board thermal resistance	20	
ψ _{JT}	Junction-to-top characterization parameter	1	
ψ _{JB}	Junction-to-board characterization parameter	18	
θ _{JCbot}	Junction-to-case (bottom) thermal resistance	n/a	

- (1) For more information about traditional and new thermal metrics, see the IC Package Thermal Metrics application report, [SPRA953](#)

RECOMMENDED OPERATING CONDITIONS

T_A = 25°C and V_{REGIN} = V_{BAT} = 3.6V (unless otherwise noted)

PARAMETER		TEST CONDITIONS	MIN	TYP	MAX	UNIT
V _{REGIN}	Supply voltage	No operating restrictions	2.7		4.5	V
		No NVM writes	2.45		2.7	
C _{REGIN}	External input capacitor for internal LDO between REGIN and V _{SS}	Nominal capacitor values specified. Recommend a 5% ceramic X5R type capacitor located close to the device.		0.1		μF
C _{LDO25}	External output capacitor for internal LDO between V _{CC} and V _{SS}		0.47	1		μF
I _{CC}	NORMAL operating-mode current ⁽¹⁾	Fuel gauge in NORMAL mode. I _{LOAD} > Sleep Current		118		μA
I _{SLP}	SLEEP mode operating mode current ⁽¹⁾	Fuel gauge in SLEEP mode. I _{LOAD} < Sleep Current		23		μA
I _{HIB}	Hibernate operating-mode current ⁽¹⁾	Fuel gauge in HIBERNATE mode. I _{LOAD} < Hibernate Current		8		μA
V _{OL(OD)}	Output low voltage on open-drain pins (SCL, SDA, GPOUT)	I _{OL} = 1 mA			0.4	V
V _{OH(OD)}	Output high voltage on open-drain pins (SDA, SCL, GPOUT)	External pullup resistor connected to V _{CC}	V _{CC} - 0.5			V
V _{IL}	Input low voltage, all digital pins		-0.3		0.6	V
V _{IH}	Input high voltage (SDA, SCL)		1.2		5.5	V
	Input high voltage (BIN)		1.2		V _{CC} + 0.3	V
V _{A2}	Input voltage range (BAT)		V _{SS} - 0.125		5	V
V _{A3}	Input voltage range (SRX) ⁽¹⁾⁽²⁾		V _{SS} - 0.040		0.040	V

- (1) Specified by design. Not production tested.

- (2) Limited by I_{SRX} maximum recommend input current with some margin for the Integrated Sense Resistor tolerance

RECOMMENDED OPERATING CONDITIONS (continued)

$T_A = 25^\circ\text{C}$ and $V_{\text{REGIN}} = V_{\text{BAT}} = 3.6\text{V}$ (unless otherwise noted)

PARAMETER		TEST CONDITIONS	MIN	TYP	MAX	UNIT
I_{ikg}	Input leakage current (I/O pins)				0.3	μA
t_{PUCD}	Power-up communication delay			250		ms

POWER-ON RESET

$T_A = -40^\circ\text{C}$ to 85°C , typical values at $T_A = 25^\circ\text{C}$ and $V_{\text{REGIN}} = 3.6\text{V}$ (unless otherwise noted)

PARAMETER		TEST CONDITIONS	MIN	TYP	MAX	UNIT
$V_{\text{IT+}}$	Positive-going voltage on V_{CC} (Regulator output)		1.98	2.20	2.31	V
V_{HYS}	Power-on reset hysteresis		43	115	185	mV

2.5V LDO REGULATOR

$T_A = 25^\circ\text{C}$, $C_{\text{LDO25}} = 1\mu\text{F}$, $V_{\text{REGIN}} = 3.6\text{V}$ (unless otherwise noted)

PARAMETER		TEST CONDITION	MIN	NOM	MAX	UNIT	
2.5 V LDO REGULATOR⁽¹⁾							
V_{REG25}	Regulator output voltage	$2.7\text{V} \leq V_{\text{REGIN}} \leq 4.5\text{V}$, $I_{\text{OUT}} \leq 5\text{mA}$	$T_A = -40^\circ\text{C}$ to 85°C	2.4	2.5	2.6	V
		$2.45\text{V} \leq V_{\text{REGIN}} < 2.7\text{V}$ (low battery), $I_{\text{OUT}} \leq 3\text{mA}$	$T_A = -40^\circ\text{C}$ to 85°C	2.4			V
$V_{\text{IH(CE)}}$	CE High-level input voltage	$V_{\text{REGIN}} = 2.7$ to 4.5V	$T_A = -40^\circ\text{C}$ to 85°C	2.65	0.8	V	
$V_{\text{IL(CE)}}$	CE Low-level input voltage						
V_{DO}	Regulator dropout voltage	2.7V , $I_{\text{OUT}} \leq 5\text{mA}$	$T_A = -40^\circ\text{C}$ to 85°C		325	mV	
		2.45V , $I_{\text{OUT}} \leq 3\text{mA}$	$T_A = -40^\circ\text{C}$ to 85°C		50		
$\Delta V_{\text{REGTEMP}}$	Regulator output change with temperature	$V_{\text{REGIN}} = 3.6\text{V}$, $I_{\text{OUT}} = 5\text{mA}$	$T_A = -40^\circ\text{C}$ to 85°C	0.5%			
$\Delta V_{\text{REGLINE}}$	Line regulation	$2.7\text{V} \leq V_{\text{REGIN}} \leq 4.5\text{V}$, $I_{\text{OUT}} = 5\text{mA}$		18	40	mV	
$\Delta V_{\text{REGLOAD}}$	Load regulation	$0.2\text{mA} \leq I_{\text{OUT}} \leq 3\text{mA}$, $V_{\text{REGIN}} = 2.45\text{V}$		34	40	mV	
		$3\text{mA} \leq I_{\text{OUT}} \leq 5\text{mA}$, $V_{\text{REGIN}} = 2.7\text{V}$		31			
$I_{\text{SHORT}}^{(2)}$	Short circuit current limit	$V_{\text{REG25}} = 0\text{V}$	$T_A = -40^\circ\text{C}$ to 85°C		250	mA	

(1) LDO output current, I_{OUT} , is the sum of internal and external load currents.

(2) Assured by design. Not production tested.

INTERNAL TEMPERATURE SENSOR CHARACTERISTICS

 $T_A = -40^{\circ}\text{C}$ to 85°C ; typical values at $T_A = 25^{\circ}\text{C}$ and $V_{\text{REGIN}} = 3.6\text{ V}$ (unless otherwise noted)

PARAMETER	TEST CONDITIONS	MIN	TYP	MAX	UNIT
G_{TEMP} Temperature sensor voltage gain			-2		mV/ $^{\circ}\text{C}$

INTEGRATING ADC (COULOMB COUNTER) CHARACTERISTICS

 $T_A = -40^{\circ}\text{C}$ to 85°C ; typical values at $T_A = 25^{\circ}\text{C}$ and $V_{\text{REGIN}} = 3.6\text{ V}$ (unless otherwise noted)

PARAMETER	TEST CONDITIONS	MIN	TYP	MAX	UNIT
V_{SR} Input voltage range ⁽¹⁾⁽²⁾	$V_{\text{SR}} = V_{(\text{SRX})} - V_{\text{SS}}$	-0.040		0.040	V
$t_{\text{SR_CONV}}$ Conversion time	Single conversion		1		s
	Resolution	14		15	bits
$V_{\text{OS(SR)}}$ Input offset			10		μV
INL Integral nonlinearity error			± 0.007	± 0.034	% FSR
$Z_{\text{IN(SR)}}$ Effective input resistance ⁽¹⁾		2.5			M Ω
$I_{\text{lkg(SR)}}$ Input leakage current ⁽¹⁾	$T_A = 25^{\circ}\text{C}$			0.3	μA

(1) Specified by design. Not tested in production.

(2) Limited by I_{SRX} maximum recommend input current with some margin for the Integrated Sense Resistor tolerance.

INTEGRATED SENSE RESISTOR CHARACTERISTICS

 $T_A = -40^{\circ}\text{C}$ to 85°C ; typical values at $T_A = 25^{\circ}\text{C}$ and $V_{\text{REGIN}} = 3.6\text{ V}$ (unless otherwise noted)

PARAMETER	TEST CONDITIONS	MIN	TYP	MAX	UNIT
SRX_{RES} Resistance of Integrated Sense Resistor from SRX to VSS. ⁽¹⁾⁽²⁾	$T_A = 25^{\circ}\text{C}$		10		m Ω
I_{SRX} Recommended Sense Resistor input current. ⁽¹⁾⁽³⁾	Long term RMS, average device utilization.			1000	mA
	Peak RMS current, 10% device utilization. ⁽³⁾			2500	mA
	Peak pulsed current, 250mS max, 1% device utilization. ⁽³⁾			3500	mA

(1) Specified by design. Not tested in production.

(2) Firmware compensation applied for temperature coefficient of resistor.

(3) Device utilization is the long term usage profile at a specific condition compared to the average condition.

ADC (TEMPERATURE AND CELL MEASUREMENT) CHARACTERISTICS

 $T_A = -40^{\circ}\text{C}$ to 85°C ; typical values at $T_A = 25^{\circ}\text{C}$ and $V_{\text{REGIN}} = 3.6\text{ V}$ (unless otherwise noted)

PARAMETER	TEST CONDITIONS	MIN	TYP	MAX	UNIT
$V_{\text{IN(ADC)}}$ Input voltage range		0.05		1	V
$t_{\text{ADC_CONV}}$ Conversion time				125	ms
	Resolution	14		15	bits
$V_{\text{OS(ADC)}}$ Input offset			1		mV
Z_{ADC} Effective input resistance (BAT) ⁽¹⁾	Not measuring cell voltage	8			M Ω
	Measuring cell voltage		100		k Ω
$I_{\text{lkg(ADC)}}$ Input leakage current ⁽¹⁾	$T_A = 25^{\circ}\text{C}$			0.3	μA

(1) Specified by design. Not tested in production.

EEPROM MEMORY CHARACTERISTICS

T_A = -40°C to 85°C; typical values at T_A = 25°C and V_{REGIN} = 3.6 V (unless otherwise noted)

PARAMETER	TEST CONDITIONS	MIN	TYP	MAX	UNIT
Array Size			256		Bytes
Data retention ⁽¹⁾		10			Years
Programming write cycles ⁽¹⁾		100K			Cycles

(1) Specified by design. Not production tested

I²C-COMPATIBLE INTERFACE COMMUNICATION TIMING CHARACTERISTICS

T_A = -40°C to 85°C; typical values at T_A = 25°C and V_{REGIN} = 3.6 V (unless otherwise noted)

PARAMETER	TEST CONDITIONS	MIN	TYP	MAX	UNIT
t _r	SCL/SDA rise time			300	ns
t _f	SCL/SDA fall time			300	ns
t _{w(H)}	SCL pulse duration (high)	600			ns
t _{w(L)}	SCL pulse duration (low)	1.3			μs
t _{su(STA)}	Setup for repeated start	600			ns
t _{d(STA)}	Start to first falling edge of SCL	600			ns
t _{su(DAT)}	Data setup time	100			ns
t _{h(DAT)}	Data hold time	0			ns
t _{su(STOP)}	Setup time for stop	600			ns
t _(BUF)	Bus free time between stop and start	66			μs
f _{SCL}	Clock frequency			400	kHz

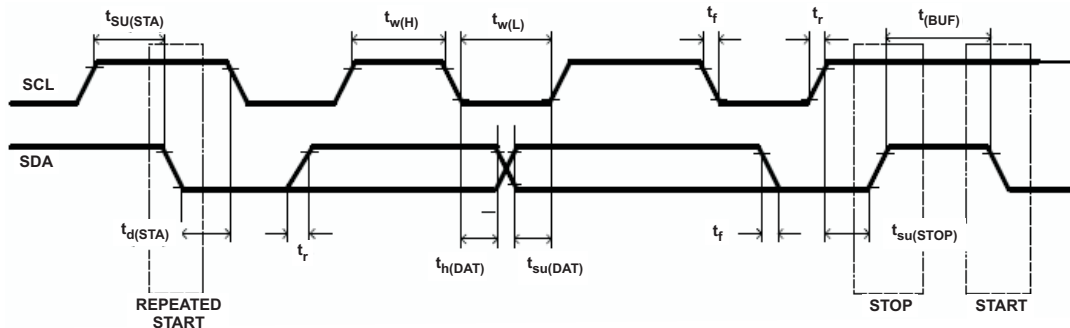

Figure 1. I²C-Compatible Interface Timing Diagrams

GENERAL DESCRIPTION

The bq27425 accurately predicts the battery capacity and other operational characteristics of a single LiCoO₂ rechargeable cell. It can be interrogated by a system processor to provide cell information, such as state-of-charge (SOC).

Information is accessed through a series of commands, called *Standard Commands*. Further capabilities are provided by the additional *Extended Commands* set. Both sets of commands, indicated by the general format *Command()*, are used to read and write information contained within the bq27425 control and status registers, as well as its data locations. Commands are sent from system to gauge using the bq27425's I²C serial communications engine, and can be executed during application development, pack manufacture, or end-equipment operation.

The key to the bq27425's high-accuracy gas gauging prediction is Texas Instrument's proprietary Impedance Track™ algorithm. This algorithm uses cell measurements, characteristics, and properties to create state-of-charge predictions that can achieve high accuracy across a wide variety of operating conditions and over the lifetime of the battery.

The bq27425 measures charge/discharge activity by monitoring the voltage across a small-value integrated sense resistor (10 mΩ typical) located between the system's V_{SS} and the battery's PACK– terminal. When a cell is attached to the bq27425, cell impedance is computed, based on cell current, cell open-circuit voltage (OCV), and cell voltage under loading conditions.

The bq27425 utilizes an integrated temperature sensor for estimating cell temperature. Alternatively, the host processor can provide temperature data for the bq27425.

To minimize power consumption, the bq27425 has several power modes: INITIALIZATION, NORMAL, SLEEP, and HIBERNATE. The bq27425 passes automatically between these modes, depending upon the occurrence of specific events, though a system processor can initiate some of these modes directly. More details can be found in Section *Power Modes*.

NOTE

FORMATTING CONVENTIONS IN THIS DOCUMENT:

Commands: *italics* with *parentheses* and no breaking spaces, e.g. *RemainingCapacity()*.

NVM Data: *italics*, **bold**, and *breaking spaces*, e.g. **Design Capacity**.

Register bits and flags: brackets and *italics*, e.g. [TDA]

NVM Data bits: brackets, *italics* and **bold**, e.g. [LED1]

Modes and states: ALL CAPITALS, e.g. UNSEALED mode.

DATA COMMANDS

Standard Data Commands

The bq27425 uses a series of 2-byte standard commands to enable system reading and writing of battery information. Each standard command has an associated command-code pair, as indicated in [Table 1](#). Because each command consists of two bytes of data, two consecutive I²C transmissions must be executed both to initiate the command function, and to read or write the corresponding two bytes of data. Additional options for transferring data, such as spooling, are described in Section, *I2C INTERFACE*. Standard commands are accessible in NORMAL operation. Read/Write permissions depend on the active access mode, SEALED or UNSEALED (for details on the SEALED and UNSEALED states, refer to Section *Access Modes*.)

Table 1. Standard Commands

NAME		COMMAND CODE	UNITS	SEALED ACCESS
<i>Control()</i>	CNTL	0x00 / 0x01	N/A	R/W
<i>Temperature()</i>	TEMP	0x02 / 0x03	0.1°K	R/W
<i>Voltage()</i>	VOLT	0x04 / 0x05	mV	R
<i>Flags()</i>	FLAGS	0x06 / 0x07	N/A	R
<i>NominalAvailableCapacity()</i>	NAC	0x08 / 0x09	mAh	R
<i>FullAvailableCapacity()</i>	FAC	0x0a / 0x0b	mAh	R
<i>RemainingCapacity()</i>	RM	0x0c / 0x0d	mAh	R
<i>FullChargeCapacity()</i>	FCC	0x0e / 0x0f	mAh	R
<i>AverageCurrent()</i>	AI	0x10 / 0x11	mA	R
<i>StandbyCurrent()</i>	SI	0x12 / 0x13	mA	R
<i>MaxLoadCurrent()</i>	MLI	0x14 / 0x15	mA	R
<i>AveragePower()</i>	AP	0x18 / 0x19	mW	R
<i>StateOfCharge()</i>	SOC	0x1c / 0x1d	%	R
<i>IntTemperature()</i>	ITEMP	0x1e / 0x1f	0.1°K	R
<i>StateofHealth()</i>	SOH	0x20 / 0x21	%	R

Control(): 0x00/0x01

Issuing a *Control()* command requires a subsequent 2-byte subcommand. These additional bytes specify the particular control function desired. The *Control()* command allows the system to control specific features of the bq27425 during normal operation and additional features when the bq27425 is in different access modes, as described in [Table 2](#).

Table 2. Control() Subcommands

CNTL FUNCTION	CNTL DATA	SEALED ACCESS	DESCRIPTION
CONTROL_STATUS	0x0000	Yes	Reports the status of device.
DEVICE_TYPE	0x0001	Yes	Reports the device type (0x0410).
FW_VERSION	0x0002	Yes	Reports the firmware version on the device type.
HW_VERSION	0x0003	Yes	Reports the hardware version of the device type.
PREV_MACWRITE	0x0007	No	Returns previous MAC command code.
BAT_INSERT	0x000c	Yes	Forces the <i>[BAT_DET]</i> bit set when the <i>[BIE]</i> bit is 0.
BAT_REMOVE	0x000d	Yes	Forces the <i>[BAT_DET]</i> bit clear when the <i>[BIE]</i> bit is 0.
SET_HIBERNATE	0x0011	Yes	Forces CONTROL_STATUS [<i>HIBERNATE</i>] to 1.
CLEAR_HIBERNATE	0x0012	Yes	Forces CONTROL_STATUS [<i>HIBERNATE</i>] to 0.
SET_CFGUPDATE	0x0013	No	Force CONTROL_STATUS [<i>CFGUPMODE</i>] to 1 and gauge enters CONFIG UPDATE mode.
SEALED	0x0020	No	Places the bq27425 in SEALED access mode.
RESET	0x0041	No	Forces a full reset of the bq27425.
SOFT_RESET	0x0042	No	Performs a soft reset to reinitialize configuration data. Forces CONTROL_STATUS [<i>CFGUPMODE</i>] to 0.

CONTROL_STATUS: 0x0000

Instructs the fuel gauge to return status information to control addresses 0x00/0x01. The status word includes the following information.

Table 3. CONTROL_STATUS Bit Definitions

	bit7	bit6	bit5	bit4	bit3	bit2	bit1	bit0
High Byte	RSVD	RSVD	SS	CALMODE	CCA	BCA	QMAX_UP	RES_UP
Low Byte	RSVD	HIBERNATE	RSVD	SLEEP	LDMD	RUP_DIS	VOK	RSVD

RSVD = Reserved.

SS = Status bit indicating the bq27425 is in the SEALED State. Active when set.

CALMODE = Status bit indicating the bq27425 is in calibration mode. Active when set.

CCA = Status bit indicating the bq27425 Coulomb Counter Auto-Calibration routine is active. The CCA routine will take place approximately 3 minutes and 45 seconds after the initialization. Active when set.

BCA = Status bit indicating the bq27425 board calibration routine is active. Active when set.

QMAX_UP = Status bit indicating Qmax has Updated. True when set. This bit is cleared after power on reset or when [BAT_DET] bit is set. When this bit is cleared, it enables fast learning of battery Qmax.

RES_UP = Status bit indicating that resistance has been updated. True when set. This bit is cleared after power on reset or when [BAT_DET] bit is set. Also this bit can only be set after Qmax is updated or QMAXU is set. When this bit is cleared, it enables fast learning of battery impedance.

HIBERNATE = Status bit indicating a request for entry into HIBERNATE from SLEEP mode has been issued. True when set. Default is 0.

SLEEP = Status bit indicating the bq27425 is in SLEEP mode. True when set.

LDMD = Status bit indicating the algorithm is using constant-power mode. True when set. Default is 1. Note: The bq27425 always uses constant-power mode.

RUP_DIS = Status bit indicating the bq27425 Ra table updates are disabled. Updates disabled when set..

VOK = Status bit indicating cell voltages are OK for Qmax updates. True when set.

DEVICE_TYPE: 0x0001

Instructs the fuel gauge to return the device type to addresses 0x00/0x01.

FW_VERSION: 0x0002

Instructs the fuel gauge to return the firmware version to addresses 0x00/0x01.

HW_VERSION: 0x0003

Instructs the fuel gauge to return the hardware version to addresses 0x00/0x01.

PREV_MACWRITE: 0x0007

Instructs the fuel gauge to return the previous command written to addresses 0x00/0x01. The value returned is limited to less than 0x0015.

BAT_INSERT: 0X000C

This subcommand forces the *Flags()* [BAT_DET] bit to set when the battery insertion detection is disabled via **OpConfig[BIE=0]**. In this case, the gauge does not detect battery insertion from the BIN pin's logic state, but relies on the BAT_INSERT host subcommand to indicate battery presence in the system. This subcommand also starts Impedance Track™ gauging.

BAT_REMOVE: 0X000D

This subcommand forces the *Flags()* [BAT_DET] bit to clear when the battery insertion detection is disabled via **OpConfig[BIE=0]**. In this case, the gauge does not detect battery removal from the BIN pin's logic state, but relies on the BAT_REMOVE host subcommand to indicate battery removal from the system.

SET_HIBERNATE: 0x0011

Instructs the fuel gauge to force the CONTROL_STATUS[HIBERNATE] bit to 1. This allows the gauge to enter the HIBERNATE power mode after the transition to SLEEP power state is detected. The [HIBERNATE] bit is automatically cleared upon exiting from HIBERNATE mode.

CLEAR_HIBERNATE: 0x0012

Instructs the fuel gauge to force the CONTROL_STATUS[HIBERNATE] and [HIBE] bit to 0. This prevents the gauge from entering the HIBERNATE power mode after the transition to SLEEP power state is detected. It can also be used to force the gauge out of HIBERNATE mode.

SET_CFGUPDATE: 0x0013

Instructs the fuel gauge to set the CONTROL_STATUS[CFGUPMODE] bit to 1 and enter CONFIG UPDATE mode. This command is only available when the fuel gauge is UNSEALED. Note: A SOFT_RESET subcommand is typically used to exit CONFIG UPDATE mode for use resume normal gauging.

FACTORY_RESTORE: 0X0015

Instructs the fuel gauge to reset learned resistance tables and Qmax values (default = **DesignCapacity**) to the default values. This command is only available when the fuel gauge is UNSEALED.

SEALED: 0x0020

Instructs the fuel gauge to transition from UNSEALED state to SEALED state. The fuel gauge should always be set to SEALED state for use in end equipment.

RESET : 0x0041

This command instructs the fuel gauge to perform a full device reset and reset RAM data to the default values from ROM. This command is only available when the fuel gauge is UNSEALED.

SOFT_RESET : 0x0042

This command instructs the fuel gauge to perform a partial reset to reinitialize configuration data and clear the ITPOR bit of the *Flags()* register to resume normal gauging from CONFIG UPDATE mode. This command is only available when the fuel gauge is UNSEALED.

Temperature(): 0x02/0x03

This read-/write-word function returns an unsigned integer value of the temperature in units of 0.1 K measured by the fuel gauge. If [TEMPS] bit = 1, a write command sets the temperature to be used for gauging calculations while a read command returns to temperature previously written. If [TEMPS] bit = 0, a read command will return the internal temperature sensor value and write command will be ignored.

Voltage(): 0x04/0x05

This read-only function returns an unsigned integer value of the measured cell-pack voltage in mV with a range of 0 to 6000 mV.

Flags(): 0x06/0x07

This read-word function returns the contents of the gas-gauge status register, depicting the current operating status.

Table 4. Flags Bit Definitions

	bit7	bit6	bit5	bit4	bit3	bit2	bit1	bit0
High Byte	OT	UT	RSVD	RSVD	RSVD	EEFAIL	FC	CHG
Low Byte	OCVTAKEN	RSVD	ITPOR	CFGUPMODE	BAT_DET	SOC1	SOCF	DSG

OT = Over-Temperature condition is detected. True when set. See [Over-Temperature Indication: Charge](#) Sub-Section.

UT = Under-Temperature condition is detected. True when set. See [Over-Temperature Indication: Discharge](#) Sub-Section.

RSVD = Reserved.

RSVD = Reserved.

RSVD = Reserved.

EEFAIL = EEPROM Write Fail. True when set. This bit is set after a single EEPROM write failure. All subsequent EEPROM writes are disabled. A power on reset or RESET subcommand is required to clear the bit to re-enable EEPROM writes.

FC = Full-charged condition reached. True when set.

CHG = (Fast) charging allowed. True when set.

OCVTAKEN = Cleared on entry to relax mode and Set to 1 when OCV measurement is performed in relax

RSVD = Reserved.

ITPOR = Indicates a Power On Reset or RESET subcommand as occurred. True when set. This bit is cleared after the SOFT_RESET subcommand is received.

CFGUPMODE = Fuel gauge is in CONFIG UPDATE mode. True when set. Default is 0. Refer to CONFIG Mode section for details.

BAT_DET = Battery insertion detected. True when set. When **OpConfig[BIE]]** is set, **[BAT_DET]** is set by detecting a logic high to low transition at BIN pin. when **OpConfig[BIE]]** is low, **[BAT_DET]** is set when host issues BAT_INSERT subcommand and clear when host issues BAT_REMOVE subcommand.

SOC1 = If set, *StateOfCharge()* <= **SOC1 Set Threshold**. The [SOC1] bit will remain set until *StateOfCharge()* >= **SOC1 Clear Threshold**.

SOCF = If set, *StateOfCharge()* <= **SOCF Set Threshold**. The [SOCF] bit will remain set until *StateOfCharge()* >= **SOCF Clear Threshold**.

DSG = Discharging detected. True when set.

NominalAvailableCapacity(): 0x08/0x09

This read-only command pair returns the uncompensated (less than C/20 load) battery capacity remaining. Units are mAh.

FullAvailableCapacity(): 0x0a/0x0b

This read-only command pair returns the uncompensated (less than C/20 load) capacity of the battery when fully charged. Units are mAh. *FullAvailableCapacity()* is updated at regular intervals, as specified by the IT algorithm.

RemainingCapacity(): 0x0c/0x0d

This read-only command pair returns the compensated battery capacity remaining. Units are mAh.

FullChargeCapacity(): 0x0e/0f

This read-only command pair returns the compensated capacity of the battery when fully charged. Units are mAh. *FullChargeCapacity()* is updated at regular intervals, as specified by the IT algorithm.

AverageCurrent(): 0x10/0x11

This read-only command pair returns a signed integer value that is the average current flow through the sense resistor. It is updated every 1 second. Units are mA.

StandbyCurrent(): 0x12/0x13

This read-only function returns a signed integer value of the measured standby current through the sense resistor. The *StandbyCurrent()* is an adaptive measurement. Initially it reports the standby current programmed in **Initial Standby** (default = -10mA), and after spending some time in standby, reports the measured standby current.

The register value is updated every 1 second when the measured current is above the **Deadband** (= ±5mA) and is less than or equal to 2 x **Initial Standby (default = -10mA)**. The first and last values that meet this criteria are not averaged in, since they may not be stable values. To approximate a 1-minute time constant, each new *StandbyCurrent()* value is computed by taking approximate 93% weight of the last standby current and approximate 7% of the current measured average current.

MaxLoadCurrent(): 0x14/0x15

This read-only function returns a signed integer value, in units of mA, of the maximum load conditions. The *MaxLoadCurrent()* is an adaptive measurement which is initially reported as the maximum load current programmed in **Initial Max Load Current** (default = -500mA). If the measured current is ever greater than **Initial Max Load Current**, then *MaxLoadCurrent()* updates to the new current. *MaxLoadCurrent()* is reduced to the average of the previous value and **Initial Max Load Current** whenever the battery is charged to full after a previous discharge to an SOC less than 50%. This prevents the reported value from maintaining an unusually high value.

AveragePower(): 0x18/0x19

This read-only function returns an signed integer value of the average power during battery charging and discharging. It is negative during discharge and positive during charge. A value of 0 indicates that the battery is not being discharged. The value is reported in units of mW.

StateOfCharge(): 0x1c/0x1d

This read-only function returns an unsigned integer value of the predicted remaining battery capacity expressed as a percentage of *FullChargeCapacity()*, with a range of 0 to 100%.

IntTemperature(): 0x1e/0x1f

This read-/write-word function returns an unsigned integer value of the internal temperature sensor in units of 0.1 K measured by the fuel gauge. If **OpConfig[WRTEMP]** = 0, this command will return the same value as *Temperature()*.

StateofHealth(): 0x20/0x21

0x20 SOH percentage: this read-only function returns an unsigned integer value, expressed as a percentage of the ratio of predicted FCC(25°C, **SOH LoadI**) over the *DesignCapacity()*. The FCC(25°C, **SOH LoadI**) is the calculated full charge capacity at 25°C and the **SOH LoadI** which is programmed in factory (default = -400mA). The range of the returned SOH percentage is 0x00 to 0x64, indicating 0 to 100% correspondingly.

0x21 SOH Status: this read-only function returns an unsigned integer value, indicating the status of the SOH percentage. The meanings of the returned value are:

- 0x00: SOH not valid (initialization)
- 0x01: Instant SOH value ready
- 0x02: Initial SOH value ready
 - Calculation based on uncompensated Qmax
 - Updated at first grid point update after cell insertion
- 0x03: SOH value ready
 - Utilize the updated Qmax update
 - Calculation based on compensated Qmax
 - Updated after complete charge and relax is complete
- 0x04-0xFF: Reserved

Extended Data Commands

Extended commands offer additional functionality beyond the standard set of commands. They are used in the same manner; however unlike standard commands, extended commands are not limited to 2-byte words. The number of command bytes for a given extended command ranges in size from single to multiple bytes, as specified in [Table 5](#).

Table 5. Extended Commands

NAME		COMMAND CODE	UNITS	SEALED ACCESS ⁽¹⁾ ⁽²⁾	UNSEALED ACCESS ⁽¹⁾ ⁽²⁾
<i>OperationConfiguration()</i>	OPCFG	0x3a / 0x3b	N/A	R	R/W
<i>DesignCapacity()</i>	DCAP	0x3c / 0x3d	mAh	R	R/W
<i>DataClass()</i> ⁽²⁾	DFCLS	0x3e	N/A	N/A	R/W
<i>DataBlock()</i> ⁽²⁾	DFBLK	0x3f	N/A	R/W	R/W
<i>BlockData()</i>	DFD	0x40...0x5f	N/A	R	R/W
<i>BlockDataCheckSum()</i>	DFDCKS	0x60	N/A	R/W	R/W
<i>BlockDataControl()</i>	DFDCNTL	0x61	N/A	N/A	R/W
<i>DeviceNameLength()</i>	DNAMELEN	0x62	N/A	R	R
<i>DeviceName()</i>	DNAME	0x63...0x69	N/A	R	R
Reserved	RSVD	0x6a...0x7f	N/A	R	R

(1) SEALED and UNSEALED states are entered via commands to **Control()** 0x00/0x01

(2) In sealed mode, data CANNOT be accessed through commands 0x3e and 0x3f.

***OperationConfiguration()*: 0x3a/0x3b**

SEALED and UNSEALED Access: This command returns the **Operation Configuration** register setting

***DesignCapacity()*: 0x3c/0x3d**

SEALED and UNSEALED Access: This command returns the value is stored in **Design Capacity** and is expressed in mAh. This is intended to be the theoretical or nominal capacity of a new pack and is used as an input for the algorithm to scale the normalized resistance tables.

***DataClass()*: 0x3e**

UNSEALED Access: This command sets the data class to be accessed. The class to be accessed should be entered in hexadecimal.

SEALED Access: This command is not available in SEALED mode.

***DataBlock()*: 0x3f**

UNSEALED Access: This command sets the data block to be accessed. When 0x00 is written to *BlockDataControl()*, *DataBlock()* holds the block number of the data to be read or written. Example: writing a 0x00 to *DataBlock()* specifies access to the first 32 byte block and a 0x01 specifies access to the second 32 byte block, and so on.

SEALED Access: This command directs which data block will be accessed by the *BlockData()* command. Issuing a 0x01 instructs the *BlockData()* command to transfer **Manufacturer Info Block A**.

***BlockData()*: 0x40...0x5f**

UNSEALED Access: This data block is the remainder of the 32 byte data block when accessing general block data.

SEALED Access: This data block is the remainder of the 32 byte data block when accessing **Manufacturer Info Block**.

BlockDataChecksum(): 0x60

UNSEALED Access: This byte contains the checksum on the 32 bytes of block data read or written. The least-significant byte of the sum of the data bytes written must be complemented ($[255 - x]$, for x the least-significant byte) before being written to 0x60.

SEALED Access: This byte contains the checksum for the 32 bytes of block data written to **Manufacturer Info Block**. The least-significant byte of the sum of the data bytes written must be complemented ($[255 - x]$, for x the least-significant byte) before being written to 0x60.

BlockDataControl(): 0x61

UNSEALED Access: This command is used to control the data access mode. Writing 0x00 to this command enables *BlockData()* to access general data NVM. Writing a 0x01 to this command enables SEALED mode operation of *DataBlock()*.

SEALED Access: This command is not available in SEALED mode.

DeviceNameLength(): 0x62

UNSEALED and SEALED Access: This byte contains the length of the **Device Name**.

DeviceName(): 0x63...0x69

UNSEALED and SEALED Access: This block contains the device name that is programmed in **Device Name**

Reserved – 0x6a – 0x7f**BLOCK DATA INTERFACE****Accessing Block Data**

The bq27425 contains both re-writable EEPROM non-volatile memory (NVM) and ROM-based data blocks. Upon device RESET, the ROM-based data blocks are copied to associated volatile RAM space to initialize default configuration and data constants to be used by the fuel gauging algorithm. Re-writable NVM-based data blocks contain information expected to change such as: calibration, customer data and Impedance Track fuel gauging data tables. If the application requires a change to the NVM or RAM configuration data, the host can update the data blocks in CONFIG UPDATE mode. RAM-based data changes are temporary and must be applied by the host using CONFIG UPDATE mode after each device RESET; while changes to the NVM data blocks are permanent. The data blocks can be accessed in several different ways, depending on the access mode and what data is being accessed.

Commonly accessed data block locations, frequently read by a system, are conveniently accessed through specific instructions, already described in Section *Data Commands*. These commands are available when the bq27425 is either in UNSEALED or SEALED modes.

Most data block locations, however, are only accessible in UNSEALED mode by use of the bq27425 evaluation software or by data block transfers. These locations should be optimized and/or fixed during the development and manufacture processes. They become part of a golden image file and can then be written to multiple battery packs. Once established, the values generally remain unchanged during end-equipment operation.

To access data locations individually, the block containing the desired data NVM location(s) must be transferred to the command register locations, where they can be read to the system or changed directly. This is accomplished by sending the set-up command *BlockDataControl()* (0x61) with data 0x00. Up to 32 bytes of data can be read directly from the *BlockData()* (0x40...0x5f), externally altered, then rewritten to the *BlockData()* command space. Alternatively, specific locations can be read, altered, and rewritten if their corresponding offsets are used to index into the *BlockData()* command space. Finally, the data residing in the command space is transferred to the associated data block, once the correct checksum for the whole block is written to *BlockDataChecksum()* (0x60).

Occasionally, a data CLASS will be larger than the 32-byte block size. In this case, the *DataBlock()* command is used to designate which 32-byte block the desired locations reside in. The correct command address is then given by $0x40 + \text{offset modulo } 32$. For example, to access **Terminate Voltage** in the *Gas Gauging* class, *DataClass()* is issued 80 (0x50) to set the class. Because the offset is 48, it must reside in the second 32-byte block. Hence, *DataBlock()* is issued 0x01 to set the block offset, and the offset used to index into the *BlockData()* memory area is $0x40 + 48 \text{ modulo } 32 = 0x40 + 16 = 0x40 + 0x10 = 0x50$.

Reading and writing subclass data are block operations up to 32 bytes in length. If during a write the data length exceeds the maximum block size, then the data is ignored.

None of the data written to memory are bounded by the bq27425, the values are not rejected by the fuel gauge. Writing an incorrect value may result in hardware failure due to firmware program interpretation of the invalid data. The data written to NVM blocks is persistent, so a power-on reset does not resolve the fault.

ACCESS MODES

The bq27425 provides three security modes (FULL ACCESS, UNSEALED, and SEALED) that control data NVM access permissions according to [Table 6](#). Although FULL ACCESS and UNSEALED modes appear identical, only FULL ACCESS mode allows the bq27425 to write access-mode transition keys.

Table 6. Data NVM Access

Security Mode	Data NVM	Manufacturer Info
FULL ACCESS	R/W	R/W
UNSEALED	R/W	R/W
SEALED	None	R

SEALING/UNSEALING DATA BLOCKS

The bq27425 implements a key-access scheme to transition between SEALED, UNSEALED, and FULL-ACCESS modes. Each transition requires that a unique set of two keys be sent to the bq27425 via the *Control()* control command. The keys must be sent consecutively, with no other data being written to the *Control()* register in between. Note that to avoid conflict, the keys must be different from the codes presented in the *CNTL DATA* column of [Table 2](#) subcommands.

When in SEALED mode the *[SS]* bit of CONTROL_STATUS is set, but when the UNSEAL keys are correctly received by the bq27425, the *[SS]* bit is cleared. When the full-access keys are correctly received then the CONTROL_STATUS *[FAS]* bit is cleared.

Both the sets of keys for each level are 2 bytes each in length and are stored in data ROM. The UNSEAL key (stored at **Unseal Key 0** and **Unseal Key 1**) and the FULL-ACCESS key (stored at **Full Access Key 0** and **Full Access Key 1**) can only be updated when in FULL-ACCESS mode. The order of the bytes entered through the *Control()* command is the reverse of what is read from the part. For example, if the 1st and 2nd word of the **UnSeal Key 0** returns 0x1234 and 0x5678, then *Control()* should supply 0x3412 and 0x7856 to unseal the part.

BLOCK DATA SUMMARY

Table 7 summarizes the data blocks available to the user, including their default, minimum, and maximum values.

Table 7. Block Data Summary

Class	SubClass ID	SubClass	Offset	Name	Data Type	Min	Max	Default	Unit (EVSW Unit)
Configuration [RAM]	2	Safety [RAM]	0	Over Temp	I2	-1200	1200	550	0.1°C
			2	Under Temp	I2	-1200	1200	0	0.1°C
			4	Temp Hys	U1	0	255	50	0.1°C
	36	Charge Termination [RAM]	0	Min Taper Capacity	I2	0	1000	25	mAh
			2	Current Taper Window	U1	0	60	40	mV
			3	TCA Set %	I1	-1	100	99	%
			4	TCA Clear %	I1	-1	100	95	%
			5	FC Set %	I1	-1	100	100	%
			6	FC Clear %	I1	-1	100	98	%
			49	Discharge [RAM]	0	SOC1 Set Threshold	U1	0	255
	1	SOC1 Clear Threshold			U1	0	255	15	%
	2	SOCF Set Threshold			U1	0	255	2	%
	3	SOCF Clear Threshold			U1	0	255	5	%
	68	Power [RAM]	9	Hibernate I	I2	0	700	3	mA
11			Hibernate V	I2	2400	3000	2550	mV	
System Data [NVM]	58	Manufacturer Info [NVM]	0-11	Block A 0-11	H1	0x0	0xff	0x0	-
Gas Gauging [NVM/RAM]	80	IT Cfg [RAM]	41	User Rate-mA	I2	2000	9000	0	mV
			43	User Rate-mW	I2	3000	14000	0	CentiW
			45	Reserve Cap-mWh	I2	0	14000	0	cWattHour
	81	Current Thresholds [RAM]	0	Dsg Current Threshold	I2	0	2000	167	mA
			2	Chg Current Threshold	I2	0	2000	133	mA
			4	Quit Current	I2	0	1000	250	mA
	82	State [NVM]	3	Reserve Cap-mAh	I2	0	9000	0	mAh
			5	Op Config	H2	0x0000	0xFFFF	0x01F8	Hex
			12	Design Capacity	I2	0	32767	1340	mAh
			14	Design Energy	I2	0	32767	4960	mWh
			18	Terminate Voltage	I2	2800	3700	3200	mV
			30	Taper Current	I2	0	1000	75	mA
			32	Taper Voltage	I2	0	5000	4100	mV
34	Sleep Current	I2	0	100	10	mA			
Ra Tables [NVM/RAM]	88	R_a [NVM]	0 - 28	Cell0 R_a 0-14	I2	Table	Table	Table	2~10Ω (num)
	89	R_a [RAM]	0 - 28	Cell0 R_a 0-14	I2	Table	Table	Table	2~10Ω (num)

Table 7. Block Data Summary (continued)

Class	SubClass ID	SubClass	Offset	Name	Data Type	Min	Max	Default	Unit (EVSW Unit)
Calibration [NVM]	104	Data [NVM]	0	CC Delta	F4	2.98E+04	1.19E+06	567744.568	num (2 [^] -10Ω)
			4	CC Offset	U2	0	65535	-1200	num (mV)
			6	Board Offset	I1	-128	127	0	num (uV)
			7	Int Temp Offset	I1	-128	127	0	num (°C)
			8	Pack V Offset	I1	-128	127	0	num (mV)
	105	CC Cal [NVM]	0	CC Gain	F4	1.00E-01	4.00E+01	0.4768	Num (2 [^] -10Ω)
			4	CC Cal Temp	I2	0	32767	2982	0.1K
Security [RAM]	112	Codes [RAM]	0	Sealed to Unsealed	H4	0x0	0xffffffff	x36720414	-

FUNCTIONAL DESCRIPTION

FUEL GAUGING

The bq27425 is an easy to configure fuel gauge that measures the cell voltage, temperature, and current to determine battery state of charge (SOC). The bq27425 monitors charge and discharge activity by sensing the voltage across a small-value resistor (5 mΩ to 20 mΩ typ.) between the SRX and VSS pins and in series with the cell. By integrating charge passing through the battery, the battery's SOC is adjusted during battery charge or discharge.

The total battery capacity is found by comparing states of charge before and after applying the load with the amount of charge passed. When an application load is applied, the impedance of the cell is measured by comparing the OCV obtained from a predefined function for present SOC with the measured voltage under load. Measurements of OCV and charge integration determine chemical state of charge and chemical capacity (Qmax). The initial Qmax values are taken from the **Design Capacity**. The bq27425 acquires and updates the battery-impedance profile during normal battery usage. It uses this profile, along with SOC and the Qmax value, to determine *FullChargeCapacity()* and *StateOfCharge()*, specifically for the present load and temperature. *FullChargeCapacity()* is reported as capacity available from a fully charged battery under the present load and temperature until *Voltage()* reaches the **Terminate Voltage**. *NominalAvailableCapacity()* and *FullAvailableCapacity()* are the uncompensated (no or light load) versions of *RemainingCapacity()* and *FullChargeCapacity()* respectively.

In addition, a FACTORY_RESTORE subcommand is provided to restore default resistance and Qmax to factory condition.

FUEL GAUGING CONFIGURATIONS

The bq27425 features easy to configure data NVM to speed-up fuel gauging design. Users are required to configure **Design Capacity**, **Termination Voltage**, and **Operation Configuration** (see [The Operation Configuration Register](#) section for details) to achieve optimal performance. The Impedance Track™ algorithm uses these parameters with its built-in parameters to achieve accurate battery fuel gauging.

Several built-in parameters are used in the Impedance Track™ algorithm to identify different modes of battery:

- Charging : **Chg Current Threshold** (default = **DesignCapacity** /13.3),
- Discharging: **Dsg Current Threshold** (default = **DesignCapacity** /16.7)
- Relax: **Quit Current Threshold** (default = **DesignCapacity** /25.0)

To achieve accurate fuel gauging, the bq27425 uses Constant Power Model for fuel gauging. This model uses the average discharge power from the beginning of the discharge cycle until present time to compute load-compensated capacity such as *RemainingCapacity()* and *FullChargeCapacity()* in the Impedance Track™ algorithm.

DETAILED PIN DESCRIPTIONS

The Operation Configuration Register

Two bq27425 pins are configured via the **Operation Configuration** data NVM register, as indicated in [Table 8](#). This register is programmed/read via the methods described in [Section Accessing the Data NVM](#).

Table 8. Operation Configuration Bit Definition

	bit7	bit6	bit5	bit4	bit3	bit2	bit1	bit0
High Byte	INTSNSSEN	RSVD0	BIE	BI_PU_EN	GNDSEL	RSVD0	RSVD0	RSVD1
Low Byte	RSVD1	RSVD1	SLEEP	RMFCC	RSVD1	BATLOWEN	GPIOPOL	WRTEMP

INTSNSSEN = Enables temperature compensation of the integrated sense resistor. Default is 0.

BIE = Battery Insertion Enable. If set, the battery insertion is detection via BIN pin input. If cleared, the detection relies on the host to issue BAT_INSERT subcommand to indicate battery presence in the system. Default is 0.

BI_PU_EN = Enables internal weak pull-up on BIN pin. Default is 0 which assumes an external pull-up resistor.

GNDSEL = The ADC ground select control. The Vss (Pin D1) is selected as ground reference when the bit is clear. Pin A1 is selected when the bit is set. Default is 0.

SLEEP = The fuel gauge can enter sleep, if operating conditions allow. True when set. Default is 1.

RMFCC = RM is updated with the value from FCC, on valid charge termination. True when set. Default is 1.

BATLOWEN = If set, the BAT_LOW function for GPOUT pin is selected. If cleared, the SOC_INT function is selected for GPOUT. Default is 0.

GPIO_POL = GPOUT pin is active-high if set or active-low if cleared. Default is 0.

WRTEMP = Enables the host to write *Temperature()* if set. If cleared, the internal temperature sensor is used for *Temperature()*. Default is 0.

RSVD0 = Reserved. Default is 0. (Set to 0 for proper operation)

RSVD1 = Reserved. Default is 1. (Set to 1 for proper operation)

GPOUT Pin

The GPOUT Pin is a multiplex pin and the polarity of the pin output can be selected via the *[GPIO_POL]* bit of the **Operation Configuration**. The function is defined by *[BATLOWEN]*. If set, the Battery Low Indicator (BAT_LOW) function for GPOUT pin is selected. If cleared, the SOC interrupt (SOC_INT) function is selected for GPOUT.

When the BAT_LOW function is activated, the signaling on the multiplexed pin follows the status of the *[SOC1]* bit in the *Flags()* register. The bq27425 has two flags accessed by the *Flags()* function that warns when the battery's SOC has fallen to critical levels. When *StateOfCharge()* falls below the first capacity threshold, specified in **SOC1 Set Threshold**, the *[SOC1]* (*State of Charge Initial*) flag is set. The flag is cleared once *StateOfCharge()* rises above **SOC1 Set Threshold**. The bq27425's GPOUT pin automatically reflects the status of the *[SOC1]* flag when **OpConfig[BATLOWEN=0]**.

When *StateOfCharge()* falls below the second capacity threshold, **SOCF Set Threshold**, the *[SOCF]* (*State of Charge Final*) flag is set, serving as a final discharge warning. Similarly, when *StateOfCharge()* rises above **SOCF Clear Threshold** and the *[SOCF]* flag has already been set, the *[SOCF]* flag is cleared.

When the SOC_INT function is activated, the GPOUT pin generates 1ms pulse width under various conditions as described in [Table 9](#).

Table 9. SOC_INT Function Definition

	Enable Condition	Pulse Width	Description
SOCI_Delta	SOCI_Delta \neq 0	1ms	<p>During charge, when the <i>StateOfCharge()</i> reaches greater than or equal to (\geq) the defined SOC_INT intervals. The intervals are defined as 100% and 100% – n \times SOCI_Delta.</p> <p>During discharge, when the <i>StateOfCharge()</i> reaches less than ($<$) the defined SOC_INT intervals. The intervals are defined as 0% and 100% – n \times SOCI_Delta.</p> <p>n: Integer value starting from 0.</p> <p>For SOCI_Delta = 10%, the SOC_INT intervals are 0%, 10%, 20%, 90%, and 100%.</p>
State Change	SOCI_Delta \neq 0	1ms	When there is a state change including charging, discharging, and relaxation.
Battery Removal	[BIE] bit is set in OpConfig	1ms	When battery removal is detected by BIN pin.

Battery Detection (BIN)

The host is responsible for battery detection by setting the [BAT_DET] bit to trigger INITIALIZATION mode. The function of *OpConfig*[BIE] bit is described in Table 10. When battery insertion is detected and INITIALIZATION mode is completed, the bq27425 runs in NORMAL mode to start Impedance Track™ fuel gauging. When battery insertion is not detected, fuel gauging is stopped.

Table 10. Battery Detection

OpConfig[BIE]	Battery Insertion Requirement	Battery Removal Requirement
1	<p>(1) Host drives BIN pin from logic high to low to signal battery insertion.</p> <p>or</p> <p>(2) A weak pull-up resistor can be used (between BIN and VCC pin). When battery pack with pull-down is connected, it can generate a logic low to signal battery insertion.</p>	<p>(1) Host drives BIN pin from logic low to high to signal battery removal.</p> <p>or</p> <p>(2) When battery pack with pull-down is removed, the weak pull-up resistor can generate a logic high to signal battery removal.</p>
0	Host sends BAT_INSERT subcommand to signal battery insertion.	Host sends BAT_REMOVE subcommand to signal battery removal.

TEMPERATURE MEASUREMENT

The bq27425 measures temperature using an on-chip temperature sensor. Alternatively if [WRTEMP] = 1, the host sends temperature data to the gauge with the initial default setting at 25°C. Regardless of [WRTEMP] setting, the fuel gauge uses temperature data in *Temperature()* command for fuel gauging.

Over-Temperature Indication: Charge

If during charging, *Temperature()* reaches the threshold of **OT Chg** (default = 55°C) for a period of **OT Chg Time** (default = 2 seconds) and *AverageCurrent()* > *Chg Current Threshold* (default = *DesignCapacity* / 13.3), then the [OTC] bit of *Flags()* is set. When *Temperature()* falls to **OT Chg Recovery** (default = 50°C), the [OTC] bit of *Flags()* is reset.

Over-Temperature Indication: Discharge

If during discharging, *Temperature()* reaches the threshold of **OT Dsg** (default = 60°C) for a period of **OT Dsg Time** (default = 2 seconds) , and *AverageCurrent()* \leq *-Dsg Current Threshold* (default = *DesignCapacity* /16.7) , then the [OTD] bit of *Flags()* is set. When *Temperature()* falls to **OT Dsg Recovery** (default = 55°C), the [OTD] bit of *Flags()* is reset.

DETECTING CHARGE TERMINATION

The bq27425 detects charge termination when (1) during 2 consecutive periods of **Current Taper Window** (default = 40 seconds), the $AverageCurrent()$ is $< Taper\ Current$ (default = 100 mA), (2) during the same periods, the accumulated change in capacity $> 0.25mAh / Current\ Taper\ Window$ (default = 40 seconds), and (3) $Voltage() > (Charging\ Voltage - 100mV)$ where **Charging Voltage** = 4200mV by default. When this occurs, the [CHG] bit of $Flags()$ is cleared. Also, if the [RMFCC] bit of **Operation Configuration** is set, and $RemainingCapacity()$ is set equal to $FullChargeCapacity()$.

Charge Inhibit

The bq27425 can indicate when battery temperature has fallen below or risen above predefined thresholds **Charge Inhibit Temp Low** (default = 0°C) or **Charge Inhibit Temp High** (default = 45°C), respectively. In this mode, the [CHG_INH] of $Flags()$ is made high to indicate this condition, and is returned to its low state, once battery temperature returns to the range [Charge Temp Low, Charge Temp High] (default = [5°C, 40°C]).

OPERATING MODES

The bq27425 has different operating modes: POR, INITIALIZATION, NORMAL, CONFIG UPDATE, SLEEP, and HIBERNATE. Following Power On Reset (POR), the fuel gauge begins INITIALIZATION. In NORMAL mode, the bq27425 is fully powered and can execute any allowable task. Configuration data in RAM and NVM can be updated by the host using the CONFIG UPDATE mode. In SLEEP mode the fuel gauge turns off the high frequency oscillator clock to enter a reduced-power state, periodically taking measurements and performing calculations. In HIBERNATE mode, the fuel gauge is in a very low power state, but can be woken up by communication or certain I/O activity.

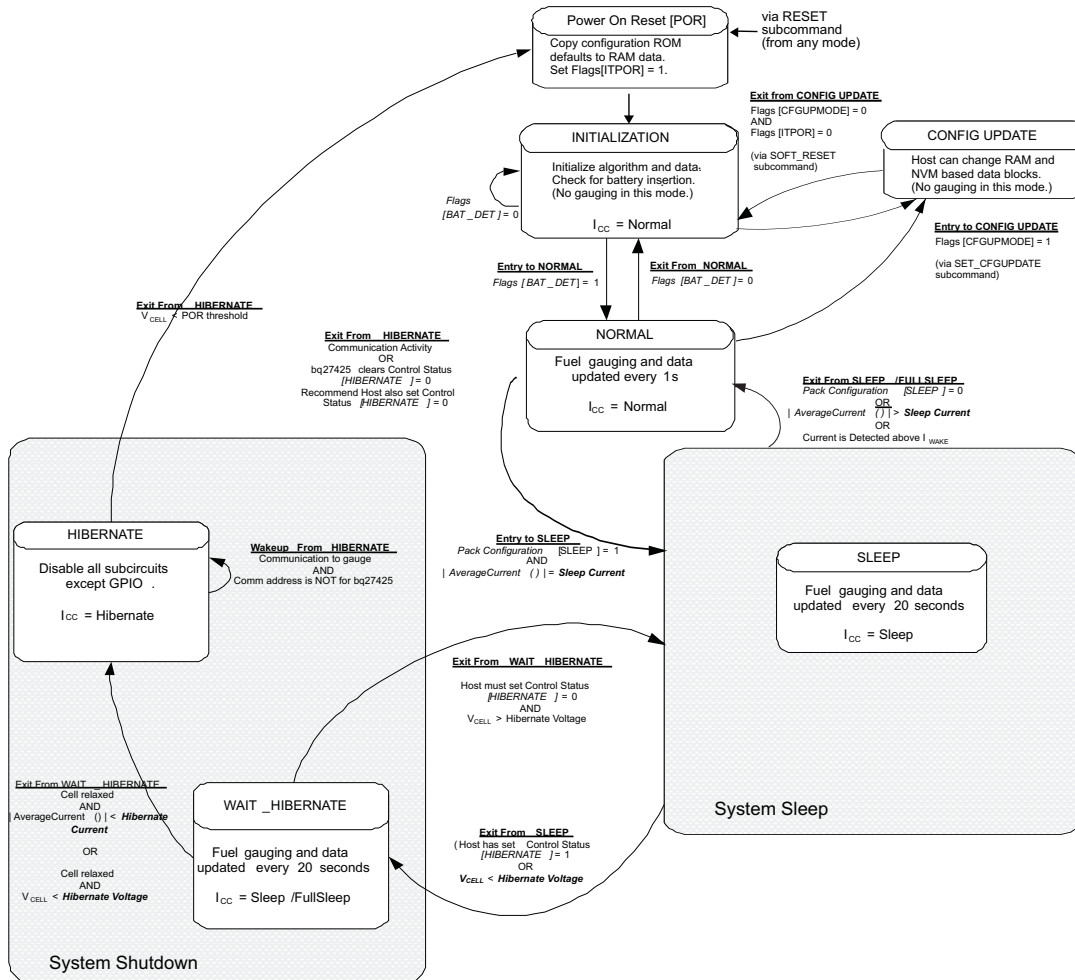

Figure 2. Power Mode Diagram

POR and INITIALIZATION Modes

Upon Power On Reset (POR), the fuel gauge copies ROM-based configuration defaults to RAM and begins INITIALIZATION mode where essential data is initialized and will remain in INITIALIZATION mode as halted-CPU state when an adapter, or other power source is present to power the bq27425 (and system), yet no battery has been detected. The occurrence of POR or a *Control()* RESET subcommand will set the *Flags()* [ITPOR] status bit to indicate that RAM has returned to ROM default data. When battery insertion is detected, a series of initialization activities begin including an OCV measurement. In addition CONTROL_STATUS[QMAXU] and [RESU] bits are cleared to allow fast learning of Qmax and impedance.

Some commands, issued by a system processor, can be processed while the bq27425 is halted in this mode. The gauge will wake up to process the command, and then return to the halted state awaiting battery insertion. The current consumption of INITIALIZATION mode is similar to NORMAL mode.

CONFIG UPDATE Mode

If the application requires different configuration data for the bq27425. The host can update both NVM and RAM based parameters using the *Control()* SET_CFGUPDATE subcommand to enter CONFIG UPDATE mode as indicated by the *Flags()* [CFGUPMODE] status bit. In this mode, fuel gauging is suspended while the host uses the Extended Data Commands to modify the configuration data blocks. To resume fuel gauging, the host sends a *Control()* SOFT_RESET subcommand to return to the INITIALIZATION mode and clear both *Flags()* [ITPOR] and [CFGUPMODE] bits.

NORMAL Mode

The fuel gauge is in NORMAL mode when not in any other power mode. During this mode, *AverageCurrent()*, *Voltage()* and *Temperature()* measurements are taken, and the interface data set is updated. Decisions to change states are also made. This mode is exited by activating a different power mode.

Because the gauge consumes the most power in NORMAL mode, the Impedance Track™ algorithm minimizes the time the fuel gauge remains in this mode.

SLEEP Mode

SLEEP mode is entered automatically if the feature is enabled (**Operation Configuration [SLEEP] = 1**) and *AverageCurrent()* is below the programmable level **Sleep Current** (default = 10mA). Once entry into SLEEP mode has been qualified, but prior to entering it, the bq27425 performs an ADC autocalibration to minimize offset.

During SLEEP mode, the bq27425 periodically takes data measurements and updates its data set. However, a majority of its time is spent in an idle condition.

The bq27425 exits SLEEP if any entry condition is broken, specifically when: *AverageCurrent()* rises above **Sleep Current** (default = 10mA).

HIBERNATE Mode

HIBERNATE mode could be used when the system equipment needs to enter a very low-power state, and minimal gauge power consumption is required. This mode is ideal when a system equipment is set to its own HIBERNATE, SHUTDOWN, or OFF modes.

Before the fuel gauge can enter HIBERNATE mode, the system must set the [HIBERNATE] bit of the CONTROL_STATUS register. The gauge waits to enter HIBERNATE mode until it has taken a valid OCV measurement and the magnitude of the average cell current has fallen below **Hibernate Current**. The gauge can also enter HIBERNATE mode if the cell voltage falls below **Hibernate Voltage**. The gauge will remain in HIBERNATE mode until the system issues a direct I²C command to the gauge. I²C Communication that is not directed to the gauge will not wake the gauge (or at least for very long).

It is the system's responsibility to wake the bq27425 after it has gone into HIBERNATE mode and prevents a charger from charging the battery before the [OCVTAKEN] bit is set which signals an OCV reading is taken. After waking, the gauge can proceed with the initialization of the battery information.

I²C INTERFACE

The bq27425 supports the standard I²C read, incremental read, quick read, one byte write, and incremental write functions. The 7 bit device address (ADDR) is the most significant 7 bits of the hex address and is fixed as 1010101. The 8-bit device address will therefore be 0xAA or 0xAB for write or read, respectively.

Host generated bq27425 generated

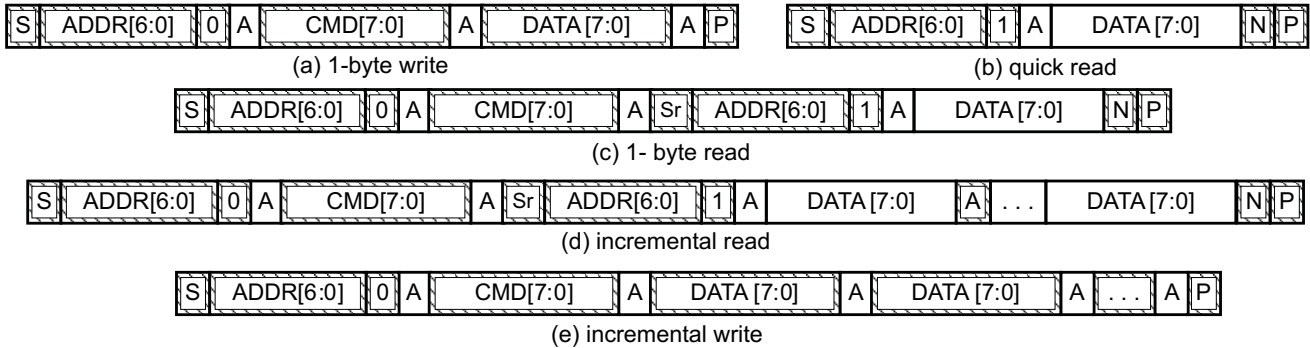

(S = Start, Sr = Repeated Start, A = Acknowledge, N = No Acknowledge, and P = Stop).

Figure 3. Supported I²C Formats

The "quick read" returns data at the address indicated by the address pointer. The address pointer, a register internal to the I²C communication engine, increments whenever data is acknowledged by the bq27425 or the I²C master. "Quick writes" function in the same manner and are a convenient means of sending multiple bytes to consecutive command locations (such as two-byte commands that require two bytes of data).

The following command sequences are not supported:

Attempt to write a read-only address (NACK after data sent by master):

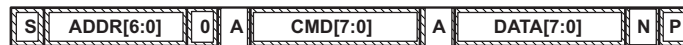

Attempt to read an address above 0x6B (NACK command):



I²C Command Waiting Time

To make sure the correct results of a command with the 400KHz I²C operation, a proper waiting time should be added between issuing command and reading results. For Subcommands, the following diagram shows, as an example, the 66 μs waiting time required between issuing the control command and reading the status data. Similarly, a 100 ms waiting time is required between the *BlockDataChecksum()* Extended command. For read-write Standard Commands, such as *Temperature()*, a minimum of 2 seconds is needed to observe the data read back following the associated data write. For read-only standard commands, there is no waiting time required; however, the host should not issue all standard commands more than two times per second. Otherwise, the gauge could result in a reset issue due to the expiration of a watchdog timer.

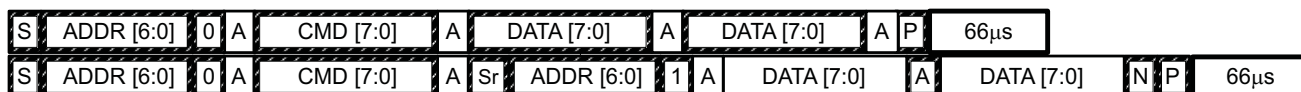

Waiting time between control subcommand and reading results

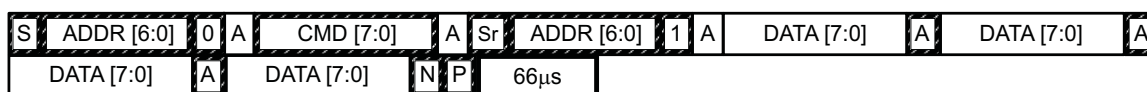

Waiting time between continuous reading results

I²C Clock Stretching

I²C clock stretches can occur during all modes of fuel gauge operation. In the SLEEP and HIBERNATE modes, a short clock stretch of approximately 75 μs will occur on all I²C traffic as the device must wake-up to process the packet. In NORMAL mode, clock stretching will only occur for packets addressed for the fuel gauge. The timing of stretches will vary as interactions between the communicating host and the gauge are asynchronous. The I²C clock stretches may occur after start bits, the ACK/NAK bit and first data bit transmit on a host read cycle. The majority of clock stretch periods are small (<= 4mSec) as the I²C interface peripheral and CPU firmware perform normal data flow control. However, very infrequent clock stretch periods of up to 144 ms maximum may occur if the host issues an I²C command while the gauge is asynchronously updating NVM data tables.

REFERENCE SCHEMATIC

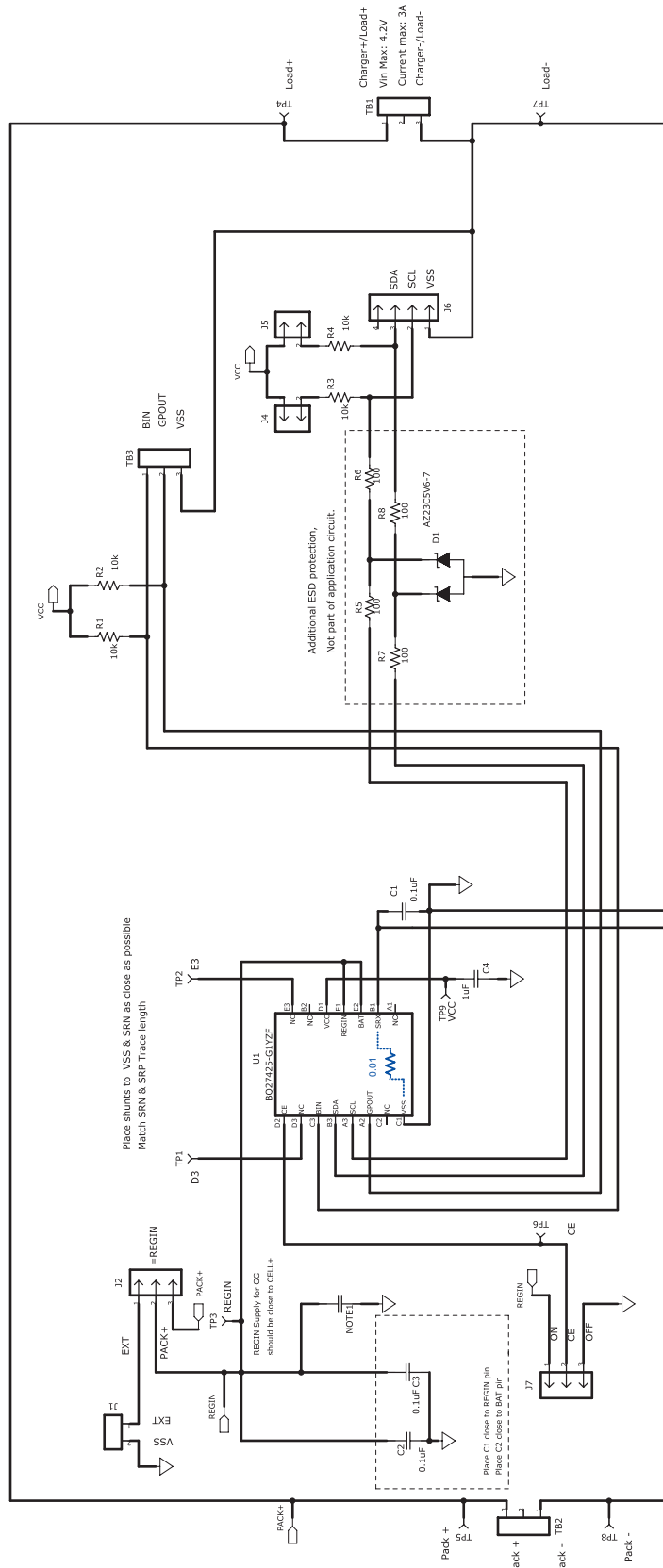

Use ground plane for SRX and VSS connection

NOTE: This is a placeholder for a TVS protection device with an 0402 package.

Package Dimensions

D	E
Max = 2720 μm	Max = 1780 μm
Min = 2660 μm	Min = 1720 μm

PACKAGING INFORMATION

Orderable Device	Status (1)	Package Type	Package Drawing	Pins	Package Qty	Eco Plan (2)	Lead/Ball Finish (6)	MSL Peak Temp (3)	Op Temp (°C)	Device Marking (4/5)	Samples
BQ27425YZFR-G1	NRND	DSBGA	YZF	15	3000	Green (RoHS & no Sb/Br)	SNAGCU	Level-1-260C-UNLIM	-40 to 85	BQ27425	
BQ27425YZFT-G1	NRND	DSBGA	YZF	15	250	Green (RoHS & no Sb/Br)	SNAGCU	Level-1-260C-UNLIM	-40 to 85	BQ27425	

(1) The marketing status values are defined as follows:

ACTIVE: Product device recommended for new designs.

LIFEBUY: TI has announced that the device will be discontinued, and a lifetime-buy period is in effect.

NRND: Not recommended for new designs. Device is in production to support existing customers, but TI does not recommend using this part in a new design.

PREVIEW: Device has been announced but is not in production. Samples may or may not be available.

OBSELETE: TI has discontinued the production of the device.

(2) Eco Plan - The planned eco-friendly classification: Pb-Free (RoHS), Pb-Free (RoHS Exempt), or Green (RoHS & no Sb/Br) - please check <http://www.ti.com/productcontent> for the latest availability information and additional product content details.

TBD: The Pb-Free/Green conversion plan has not been defined.

Pb-Free (RoHS): TI's terms "Lead-Free" or "Pb-Free" mean semiconductor products that are compatible with the current RoHS requirements for all 6 substances, including the requirement that lead not exceed 0.1% by weight in homogeneous materials. Where designed to be soldered at high temperatures, TI Pb-Free products are suitable for use in specified lead-free processes.

Pb-Free (RoHS Exempt): This component has a RoHS exemption for either 1) lead-based flip-chip solder bumps used between the die and package, or 2) lead-based die adhesive used between the die and leadframe. The component is otherwise considered Pb-Free (RoHS compatible) as defined above.

Green (RoHS & no Sb/Br): TI defines "Green" to mean Pb-Free (RoHS compatible), and free of Bromine (Br) and Antimony (Sb) based flame retardants (Br or Sb do not exceed 0.1% by weight in homogeneous material)

(3) MSL, Peak Temp. - The Moisture Sensitivity Level rating according to the JEDEC industry standard classifications, and peak solder temperature.

(4) There may be additional marking, which relates to the logo, the lot trace code information, or the environmental category on the device.

(5) Multiple Device Markings will be inside parentheses. Only one Device Marking contained in parentheses and separated by a "~" will appear on a device. If a line is indented then it is a continuation of the previous line and the two combined represent the entire Device Marking for that device.

(6) Lead/Ball Finish - Orderable Devices may have multiple material finish options. Finish options are separated by a vertical ruled line. Lead/Ball Finish values may wrap to two lines if the finish value exceeds the maximum column width.

Important Information and Disclaimer: The information provided on this page represents TI's knowledge and belief as of the date that it is provided. TI bases its knowledge and belief on information provided by third parties, and makes no representation or warranty as to the accuracy of such information. Efforts are underway to better integrate information from third parties. TI has taken and continues to take reasonable steps to provide representative and accurate information but may not have conducted destructive testing or chemical analysis on incoming materials and chemicals. TI and TI suppliers consider certain information to be proprietary, and thus CAS numbers and other limited information may not be available for release.

In no event shall TI's liability arising out of such information exceed the total purchase price of the TI part(s) at issue in this document sold by TI to Customer on an annual basis.

TAPE AND REEL INFORMATION

QUADRANT ASSIGNMENTS FOR PIN 1 ORIENTATION IN TAPE

*All dimensions are nominal

Device	Package Type	Package Drawing	Pins	SPQ	Reel Diameter (mm)	Reel Width W1 (mm)	A0 (mm)	B0 (mm)	K0 (mm)	P1 (mm)	W (mm)	Pin1 Quadrant
BQ27425YZFR-G1	DSBGA	YZF	15	3000	180.0	8.4	2.0	2.8	0.7	4.0	8.0	Q1
BQ27425YZFT-G1	DSBGA	YZF	15	250	180.0	8.4	2.0	2.8	0.7	4.0	8.0	Q1

TAPE AND REEL BOX DIMENSIONS



*All dimensions are nominal

Device	Package Type	Package Drawing	Pins	SPQ	Length (mm)	Width (mm)	Height (mm)
BQ27425YZFR-G1	DSBGA	YZF	15	3000	182.0	182.0	20.0
BQ27425YZFT-G1	DSBGA	YZF	15	250	182.0	182.0	20.0

YZF0015

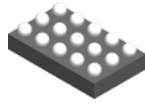

PACKAGE OUTLINE

DSBGA - 0.625 mm max height

DIE SIZE BALL GRID ARRAY

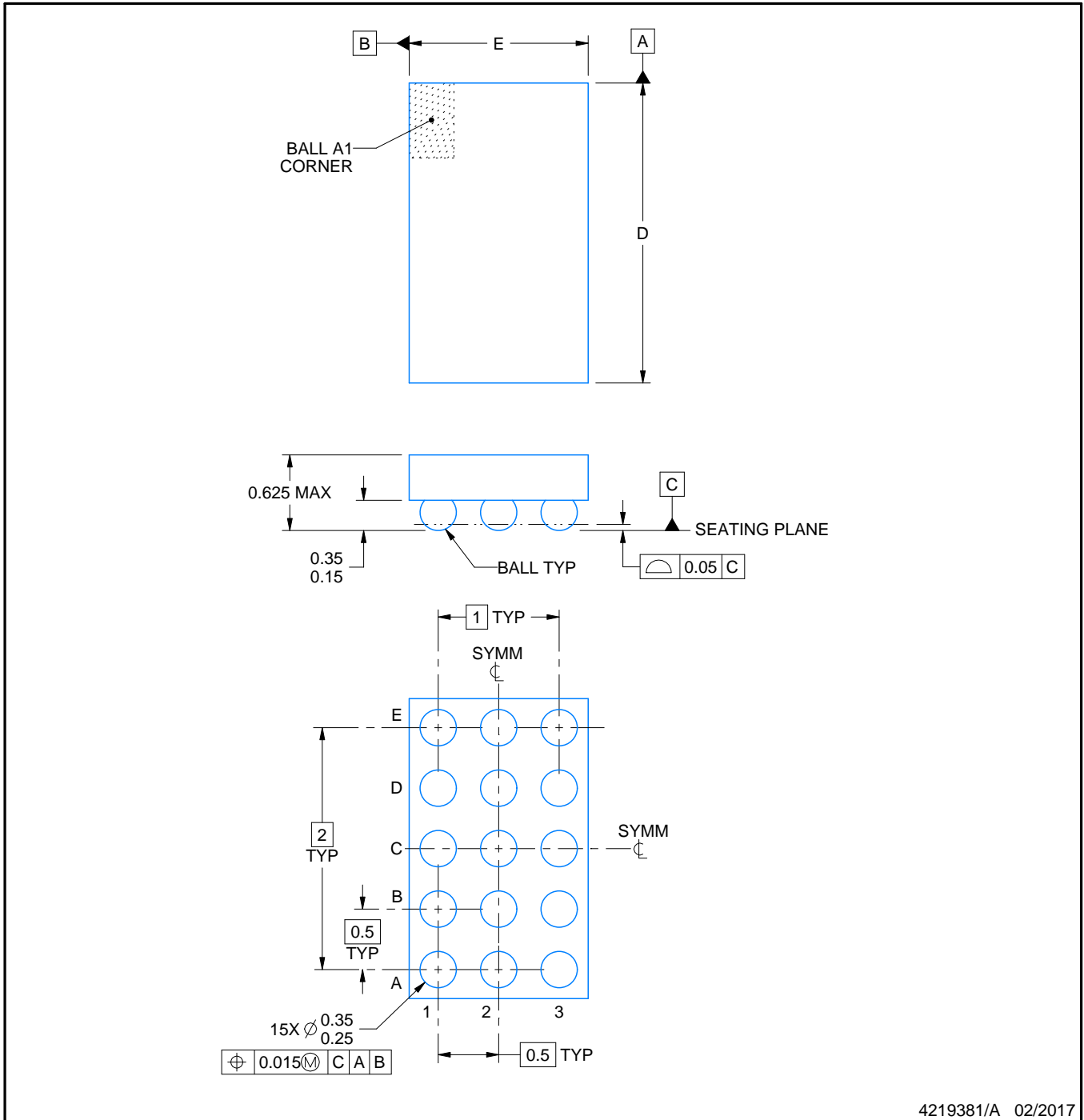

4219381/A 02/2017

NOTES:

NanoFree Is a trademark of Texas Instruments.

1. All linear dimensions are in millimeters. Any dimensions in parenthesis are for reference only. Dimensioning and tolerancing per ASME Y14.5M.
2. This drawing is subject to change without notice.
3. NanoFree™ package configuration.

EXAMPLE BOARD LAYOUT

YZF0015

DSBGA - 0.625 mm max height

DIE SIZE BALL GRID ARRAY

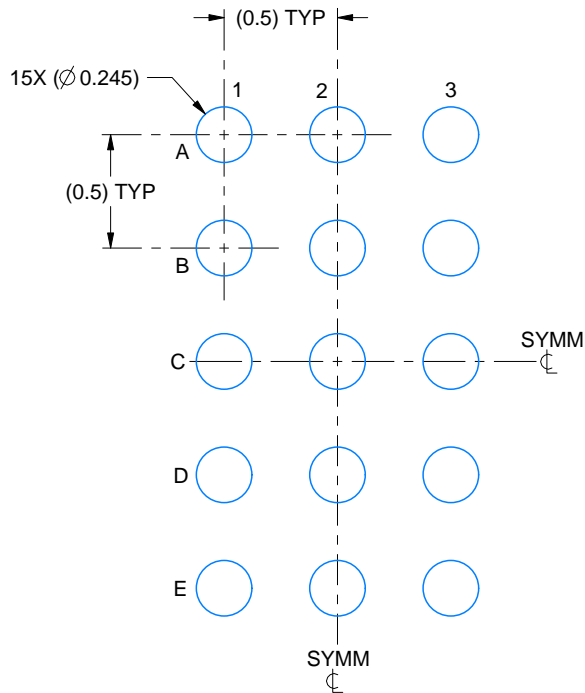

LAND PATTERN EXAMPLE
EXPOSED METAL SHOWN
SCALE:30X

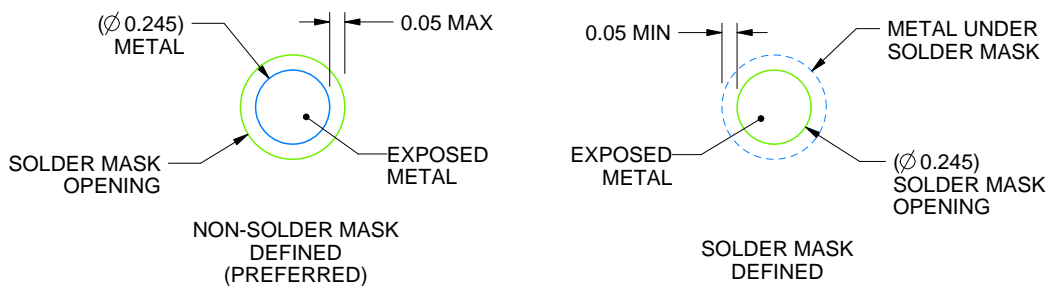

SOLDER MASK DETAILS
NOT TO SCALE

4219381/A 02/2017

NOTES: (continued)

- Final dimensions may vary due to manufacturing tolerance considerations and also routing constraints. For more information, see Texas Instruments literature number SNVA009 (www.ti.com/lit/snva009).

EXAMPLE STENCIL DESIGN

YZF0015

DSBGA - 0.625 mm max height

DIE SIZE BALL GRID ARRAY

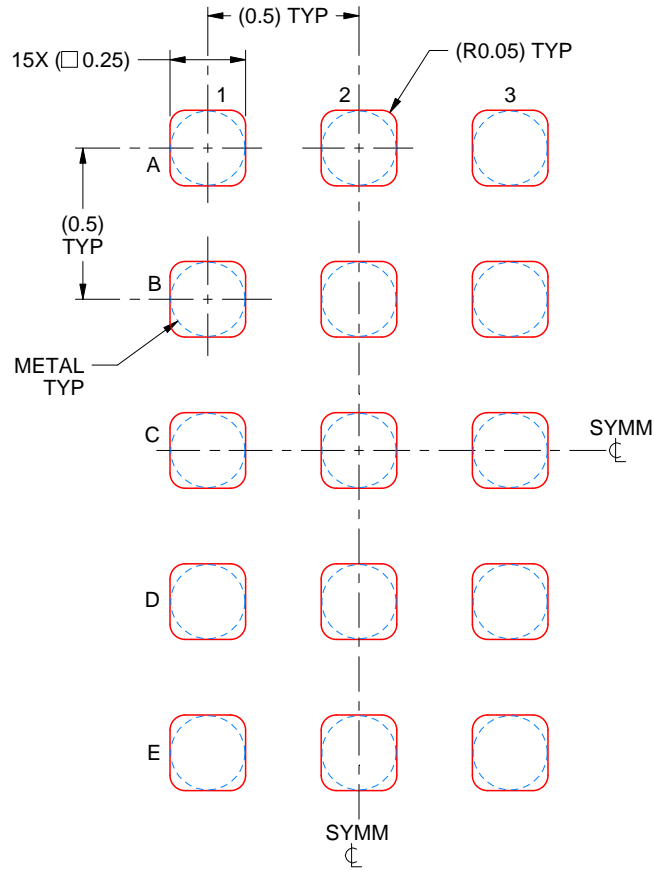

SOLDER PASTE EXAMPLE
BASED ON 0.1 mm THICK STENCIL
SCALE:40X

4219381/A 02/2017

NOTES: (continued)

5. Laser cutting apertures with trapezoidal walls and rounded corners may offer better paste release.

IMPORTANT NOTICE FOR TI DESIGN INFORMATION AND RESOURCES

Texas Instruments Incorporated ("TI") technical, application or other design advice, services or information, including, but not limited to, reference designs and materials relating to evaluation modules, (collectively, "TI Resources") are intended to assist designers who are developing applications that incorporate TI products; by downloading, accessing or using any particular TI Resource in any way, you (individually or, if you are acting on behalf of a company, your company) agree to use it solely for this purpose and subject to the terms of this Notice.

TI's provision of TI Resources does not expand or otherwise alter TI's applicable published warranties or warranty disclaimers for TI products, and no additional obligations or liabilities arise from TI providing such TI Resources. TI reserves the right to make corrections, enhancements, improvements and other changes to its TI Resources.

You understand and agree that you remain responsible for using your independent analysis, evaluation and judgment in designing your applications and that you have full and exclusive responsibility to assure the safety of your applications and compliance of your applications (and of all TI products used in or for your applications) with all applicable regulations, laws and other applicable requirements. You represent that, with respect to your applications, you have all the necessary expertise to create and implement safeguards that (1) anticipate dangerous consequences of failures, (2) monitor failures and their consequences, and (3) lessen the likelihood of failures that might cause harm and take appropriate actions. You agree that prior to using or distributing any applications that include TI products, you will thoroughly test such applications and the functionality of such TI products as used in such applications. TI has not conducted any testing other than that specifically described in the published documentation for a particular TI Resource.

You are authorized to use, copy and modify any individual TI Resource only in connection with the development of applications that include the TI product(s) identified in such TI Resource. NO OTHER LICENSE, EXPRESS OR IMPLIED, BY ESTOPPEL OR OTHERWISE TO ANY OTHER TI INTELLECTUAL PROPERTY RIGHT, AND NO LICENSE TO ANY TECHNOLOGY OR INTELLECTUAL PROPERTY RIGHT OF TI OR ANY THIRD PARTY IS GRANTED HEREIN, including but not limited to any patent right, copyright, mask work right, or other intellectual property right relating to any combination, machine, or process in which TI products or services are used. Information regarding or referencing third-party products or services does not constitute a license to use such products or services, or a warranty or endorsement thereof. Use of TI Resources may require a license from a third party under the patents or other intellectual property of the third party, or a license from TI under the patents or other intellectual property of TI.

TI RESOURCES ARE PROVIDED "AS IS" AND WITH ALL FAULTS. TI DISCLAIMS ALL OTHER WARRANTIES OR REPRESENTATIONS, EXPRESS OR IMPLIED, REGARDING TI RESOURCES OR USE THEREOF, INCLUDING BUT NOT LIMITED TO ACCURACY OR COMPLETENESS, TITLE, ANY EPIDEMIC FAILURE WARRANTY AND ANY IMPLIED WARRANTIES OF MERCHANTABILITY, FITNESS FOR A PARTICULAR PURPOSE, AND NON-INFRINGEMENT OF ANY THIRD PARTY INTELLECTUAL PROPERTY RIGHTS.

TI SHALL NOT BE LIABLE FOR AND SHALL NOT DEFEND OR INDEMNIFY YOU AGAINST ANY CLAIM, INCLUDING BUT NOT LIMITED TO ANY INFRINGEMENT CLAIM THAT RELATES TO OR IS BASED ON ANY COMBINATION OF PRODUCTS EVEN IF DESCRIBED IN TI RESOURCES OR OTHERWISE. IN NO EVENT SHALL TI BE LIABLE FOR ANY ACTUAL, DIRECT, SPECIAL, COLLATERAL, INDIRECT, PUNITIVE, INCIDENTAL, CONSEQUENTIAL OR EXEMPLARY DAMAGES IN CONNECTION WITH OR ARISING OUT OF TI RESOURCES OR USE THEREOF, AND REGARDLESS OF WHETHER TI HAS BEEN ADVISED OF THE POSSIBILITY OF SUCH DAMAGES.

You agree to fully indemnify TI and its representatives against any damages, costs, losses, and/or liabilities arising out of your non-compliance with the terms and provisions of this Notice.

This Notice applies to TI Resources. Additional terms apply to the use and purchase of certain types of materials, TI products and services. These include; without limitation, TI's standard terms for semiconductor products (<http://www.ti.com/sc/docs/stdterms.htm>), [evaluation modules](#), and [samples](http://www.ti.com/sc/docs/sampterm.htm) (<http://www.ti.com/sc/docs/sampterm.htm>).

Mailing Address: Texas Instruments, Post Office Box 655303, Dallas, Texas 75265
Copyright © 2017, Texas Instruments Incorporated