

## DLP9500 DLP® 0.95 1080p 2x LVDS Type A DMD

### 1 Features

- 0.95-Inch Diagonal Micromirror Array
  - 1920 × 1080 Array of Aluminum, Micrometer-Sized Mirrors (1080p Resolution)
  - 10.8- $\mu\text{m}$  Micromirror Pitch
  - $\pm 12^\circ$  Micromirror Tilt Angle (Relative to Flat State)
  - Designed for Corner Illumination
- Designed for Use with Visible Light (400 to 700 nm):
  - Window Transmission 97% (Single Pass, Through Two Window Surfaces)
  - Micromirror Reflectivity 88%
  - Array Diffraction Efficiency 86%
  - Array Fill Factor 92%
- Four 16-Bit, Low-Voltage Differential Signaling (LVDS), Double Data Rate (DDR) Input Data Buses
- Up to 400-MHz Input Data Clock Rate
- 42.2-mm × 42.2-mm × 7-mm Package Footprint
- Hermetic Package

### 2 Applications

- Industrial:
  - Digital Imaging Lithography
  - Laser Marking
  - LCD and OLED Repair
  - Computer-to-Plate Printers
  - SLA 3D Printers
  - 3D Scanners for Machine Vision and Factory Automation
  - Flat Panel Lithography
- Medical:
  - Phototherapy Devices
  - Ophthalmology
  - Direct Manufacturing
  - Hyperspectral Imaging
  - 3D Biometrics
  - Confocal Microscopes
- Display:
  - 3D Imaging Microscopes
  - Adaptive Illumination
  - Augmented Reality and Information Overlay

### 3 Description

The DLP9500 1080p chipset is part of the DLP® Discovery™ 4100 platform, which enables high resolution and high performance spatial light modulation. The DLP9500 is the digital micromirror device (DMD) fundamental to the 0.95 1080p chipset. The DLP Discovery 4100 platform also provides the highest level of individual micromirror control with the option for random row addressing. Combined with a hermetic package, the unique capability and value offered by DLP9500 makes it well suited to support a wide variety of industrial, medical, and advanced display applications.

In addition to the DLP9500 DMD, the 0.95 1080p chipset includes a dedicated DLPC410 controller required for high speed pattern rates of >23000 Hz (1-bit binary) and >1700 Hz (8-bit gray), one unit DLPR410 (DLP Discovery 4100 Configuration PROM), and two units DLPA200 (DMD micromirror drivers).

Reliable function and operation of the DLP9500 requires that it be used in conjunction with the other components of the chipset. A dedicated chipset provides developers easier access to the DMD as well as high speed, independent micromirror control.

DLP9500 is a digitally controlled micro-electromechanical system (MEMS) spatial light modulator (SLM). When coupled to an appropriate optical system, the DLP9500 can be used to modulate the amplitude, direction, and/or phase of incoming light.

#### Device Information <sup>(1)</sup>

PART NUMBER	PACKAGE	BODY SIZE (NOM)
DLP9500	LCCC (355)	42.16 mm × 42.16 mm

(1) For all available packages, see the orderable addendum at the end of the data sheet.

#### Simplified Schematic

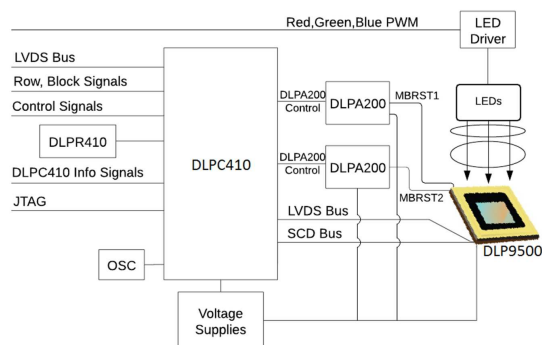

## Table of Contents

<b>1 Features</b> .....	1	8.3 Feature Description .....	26
<b>2 Applications</b> .....	1	8.4 Device Functional Modes .....	32
<b>3 Description</b> .....	1	8.5 Window Characteristics and Optics .....	34
<b>4 Revision History</b> .....	2	8.6 Micromirror Array Temperature Calculation .....	35
<b>5 Description (continued)</b> .....	4	8.7 Micromirror Landed-On and Landed-Off Duty Cycle .....	37
<b>6 Pin Configuration and Functions</b> .....	4	<b>9 Application and Implementation</b> .....	39
<b>7 Specifications</b> .....	13	9.1 Application Information .....	39
7.1 Absolute Maximum Ratings .....	13	9.2 Typical Application .....	40
7.2 Storage Conditions .....	13	<b>10 Power Supply Recommendations</b> .....	42
7.3 ESD Ratings .....	13	10.1 Power-Up Sequence (Handled by the DLPC410) .....	42
7.4 Recommended Operating Conditions .....	14	10.2 DMD Power-Up and Power-Down Procedures .....	42
7.5 Thermal Information .....	15	<b>11 Layout</b> .....	43
7.6 Electrical Characteristics .....	16	11.1 Layout Guidelines .....	43
7.7 LVDS Timing Requirements .....	17	11.2 Layout Example .....	45
7.8 LVDS Waveform Requirements .....	18	<b>12 Device and Documentation Support</b> .....	46
7.9 Serial Control Bus Timing Requirements .....	19	12.1 Device Support .....	46
7.10 Systems Mounting Interface Loads .....	20	12.2 Documentation Support .....	47
7.11 Micromirror Array Physical Characteristics .....	21	12.3 Related Links .....	47
7.12 Micromirror Array Optical Characteristics .....	22	12.4 Community Resources .....	47
7.13 Window Characteristics .....	23	12.5 Trademarks .....	47
7.14 Chipset Component Usage Specification .....	23	12.6 Electrostatic Discharge Caution .....	47
<b>8 Detailed Description</b> .....	24	12.7 Glossary .....	47
8.1 Overview .....	24	<b>13 Mechanical, Packaging, and Orderable Information</b> .....	47
8.2 Functional Block Diagram .....	24		

## 4 Revision History

NOTE: Page numbers for previous revisions may differ from page numbers in the current version.

Changes from Revision C (September 2015) to Revision D	Page
• Removed '692' from Pin Configurations image .....	4
• Added RH name for relative humidity in <a href="#">Absolute Maximum Ratings</a> .....	13
• Clarified T <sub>GRADIENT</sub> footnote in <a href="#">Absolute Maximum Ratings</a> .....	13
• Changed T <sub>stg</sub> to T <sub>DMD</sub> in <a href="#">Storage Conditions</a> to conform to current nomenclature .....	13
• Changed SUPPLY VOLTAGES heading to ELECTRICAL in <a href="#">Recommended Operating Conditions</a> .....	14
• Changed Environmental sections of <a href="#">Recommended Operating Conditions</a> - Simplified to one Environmental section with Illumination power densities in a single group .....	14
• Added Maximum illumination power values for 363 to 400 nm, 400 to 420 nm, and 363 to 420 nm total power values in <a href="#">Recommended Operating Conditions</a> .....	14
• Changed 400-420 nm illumination from 2.5 to 11 W/cm <sup>2</sup> in <a href="#">Recommended Operating Conditions</a> .....	14
• Added 400-420 nm illumination power of 26.6 W in <a href="#">Recommended Operating Conditions</a> .....	14
• Changed typical micromirror crossover time to the time required to transition from mirror position to the other in <a href="#">Micromirror Array Optical Characteristics</a> .....	22
• Added typical micromirror switching time - 13 μs in <a href="#">Micromirror Array Optical Characteristics</a> .....	22
• Changed "Micromirror switching time" to "Array switching time" for clarity in <a href="#">Micromirror Array Optical Characteristics</a> .....	22
• Added clarification to Micromirror switching time at 400 MHz with global reset in <a href="#">Micromirror Array Optical Characteristics</a> .....	22
• Updated <a href="#">Figure 20</a> and <a href="#">Figure 21</a> .....	46
• Added <a href="#">Related Links</a> table .....	47

<b>Changes from Revision B (July 2013) to Revision C</b>	<b>Page</b>
• Added <i>ESD Ratings</i> table, <i>Feature Description</i> section, <i>Device Functional Modes</i> , <i>Application and Implementation</i> section, <i>Power Supply Recommendations</i> section, <i>Layout</i> section, <i>Device and Documentation Support</i> section, and <i>Mechanical, Packaging, and Orderable Information</i> section .....	1
• Minor wording changes in Features and Description sections .....	1
• Changed name of Micromirror clocking pulse reset .....	11
• Changed ESD Ratings table to match new standard .....	13
• Adjusted recommended power density conditions .....	14
• Changed thermal test points to match new test point diagram .....	14
• Added Max Recommended DMD Temperature – Derating Curve .....	15
• Moved Max Recommended DMD Temperature – Derating Curve to <i>Recommended Operating Conditions</i> .....	15
• Replaced <a href="#">Figure 4</a> .....	19
• Changed units from lbs to N .....	20
• Added explanation for the 15 MBRST lines to the DLP9500 from each DLPA200 .....	26
• Changed Thermal Test Point Location graphic .....	35
• Added program interface to system interface list in <i>Design Requirements</i> .....	41
• Corrected number of banks of DMD mirrors to 15 .....	41
• Removed link to DLP Discovery 4100 chipset datasheet .....	47
• Added <a href="#">Community Resources</a> .....	47

<b>Changes from Revision A (September 2012) to Revision B</b>	<b>Page</b>
• Added DLPR4101 enhanced PROM to DLPR410 in chipset list .....	1
• Added DLPR4101 Enhanced PROM to DLPR410 in Related Documentation .....	47

<b>Changes from Original (August 2012) to Revision A</b>	<b>Page</b>
• Changed the device From: Product Preview To: Production .....	1

## 5 Description (continued)

Electrically, the DLP9500 consists of a two-dimensional array of 1-bit CMOS memory cells, organized in a grid of 1920 memory cell columns by 1080 memory cell rows. The CMOS memory array is addressed on a row-by-row basis, over four 16-bit LVDS DDR buses. Addressing is handled by a serial control bus. The specific CMOS memory access protocol is handled by the DLPC410 digital controller.

## 6 Pin Configuration and Functions

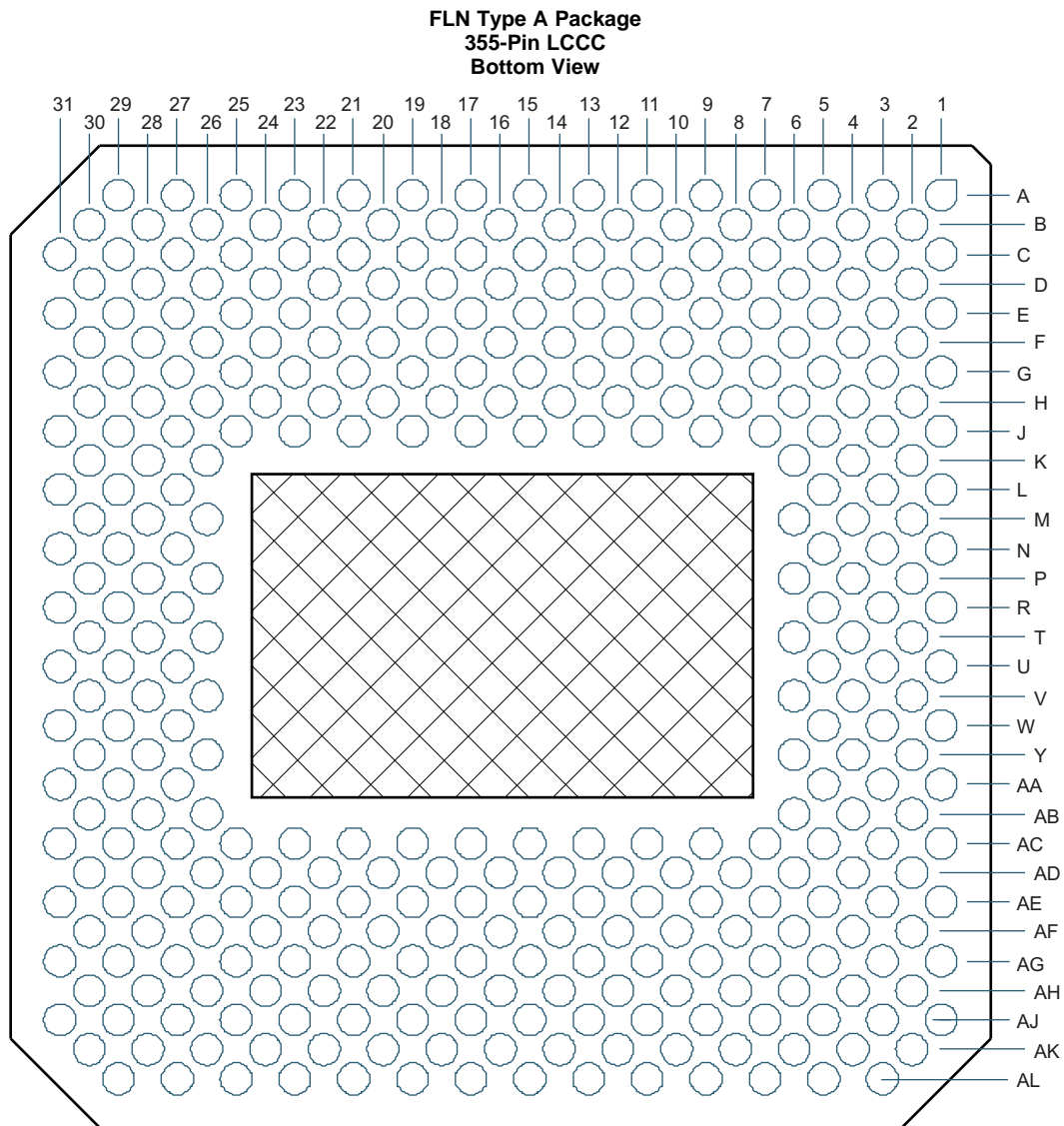

**Pin Functions**

PIN <sup>(1)</sup>		TYPE (I/O/P)	SIGNAL	DATA RATE <sup>(2)</sup>	INTERNAL TERM <sup>(3)</sup>	CLOCK	DESCRIPTION	TRACE (MILS)
NAME	NO.							
<b>DATA BUS A</b>								
D_AN(0)	F2	Input	LVC MOS	DDR	Differentially terminated – 100 Ω	DCLK_A	Input data bus A (2x LVDS)	512.01
D_AN(1)	H8	Input	LVC MOS	DDR	Differentially terminated – 100 Ω	DCLK_A		158.79
D_AN(2)	E5	Input	LVC MOS	DDR	Differentially terminated – 100 Ω	DCLK_A		471.24
D_AN(3)	G9	Input	LVC MOS	DDR	Differentially terminated – 100 Ω	DCLK_A		159.33
D_AN(4)	D2	Input	LVC MOS	DDR	Differentially terminated – 100 Ω	DCLK_A		585.41
D_AN(5)	G3	Input	LVC MOS	DDR	Differentially terminated – 100 Ω	DCLK_A		551.17
D_AN(6)	E11	Input	LVC MOS	DDR	Differentially terminated – 100 Ω	DCLK_A		229.41
D_AN(7)	F8	Input	LVC MOS	DDR	Differentially terminated – 100 Ω	DCLK_A		300.54
D_AN(8)	C9	Input	LVC MOS	DDR	Differentially terminated – 100 Ω	DCLK_A		346.35
D_AN(9)	H2	Input	LVC MOS	DDR	Differentially terminated – 100 Ω	DCLK_A		782.27
D_AN(10)	B10	Input	LVC MOS	DDR	Differentially terminated – 100 Ω	DCLK_A		451.52
D_AN(11)	G15	Input	LVC MOS	DDR	Differentially terminated – 100 Ω	DCLK_A		74.39
D_AN(12)	D14	Input	LVC MOS	DDR	Differentially terminated – 100 Ω	DCLK_A		194.26
D_AN(13)	F14	Input	LVC MOS	DDR	Differentially terminated – 100 Ω	DCLK_A		148.29
D_AN(14)	C17	Input	LVC MOS	DDR	Differentially terminated – 100 Ω	DCLK_A		244.9
D_AN(15)	H16	Input	LVC MOS	DDR	Differentially terminated – 100 Ω	DCLK_A		73.39
D_AP(0)	F4	Input	LVC MOS	DDR	Differentially terminated – 100 Ω	DCLK_A		509.63
D_AP(1)	H10	Input	LVC MOS	DDR	Differentially terminated – 100 Ω	DCLK_A		152.59
D_AP(2)	E3	Input	LVC MOS	DDR	Differentially terminated – 100 Ω	DCLK_A		464.09
D_AP(3)	G11	Input	LVC MOS	DDR	Differentially terminated – 100 Ω	DCLK_A		152.39
D_AP(4)	D4	Input	LVC MOS	DDR	Differentially terminated – 100 Ω	DCLK_A	591.39	
D_AP(5)	G5	Input	LVC MOS	DDR	Differentially terminated – 100 Ω	DCLK_A	532.16	
D_AP(6)	E9	Input	LVC MOS	DDR	Differentially terminated – 100 Ω	DCLK_A	230.78	
D_AP(7)	F10	Input	LVC MOS	DDR	Differentially terminated – 100 Ω	DCLK_A	300.61	
D_AP(8)	C11	Input	LVC MOS	DDR	Differentially terminated – 100 Ω	DCLK_A	338.16	
D_AP(9)	H4	Input	LVC MOS	DDR	Differentially terminated – 100 Ω	DCLK_A	773.17	
D_AP(10)	B8	Input	LVC MOS	DDR	Differentially terminated – 100 Ω	DCLK_A	449.57	

(1) The following power supplies are required to operate the DMD: VCC, VCC1, VCC2. VSS must also be connected.

(2) DDR = Double Data Rate. SDR = Single Data Rate. Refer to the [LVDS Timing Requirements](#) for specifications and relationships.

(3) Refer to [Electrical Characteristics](#) for differential termination specification.

**Pin Functions (continued)**

PIN <sup>(1)</sup>		TYPE (I/O/P)	SIGNAL	DATA RATE <sup>(2)</sup>	INTERNAL TERM <sup>(3)</sup>	CLOCK	DESCRIPTION	TRACE (MILS)
NAME	NO.							
D_AP(11)	H14	Input	LVC MOS	DDR	Differentially terminated – 100 Ω	DCLK_A	Input data bus A (2x LVDS)	71.7
D_AP(12)	D16	Input	LVC MOS	DDR	Differentially terminated – 100 Ω	DCLK_A		198.69
D_AP(13)	F16	Input	LVC MOS	DDR	Differentially terminated – 100 Ω	DCLK_A		143.72
D_AP(14)	C15	Input	LVC MOS	DDR	Differentially terminated – 100 Ω	DCLK_A		240.14
D_AP(15)	G17	Input	LVC MOS	DDR	Differentially terminated – 100 Ω	DCLK_A		74.05
<b>DATA BUS B</b>								
D_BN(0)	AH2	Input	LVC MOS	DDR	Differentially terminated – 100 Ω	DCLK_B	Input data bus B (2x LVDS)	525.25
D_BN(1)	AD8	Input	LVC MOS	DDR	Differentially terminated – 100 Ω	DCLK_B		190.59
D_BN(2)	AJ5	Input	LVC MOS	DDR	Differentially terminated – 100 Ω	DCLK_B		525.25
D_BN(3)	AE3	Input	LVC MOS	DDR	Differentially terminated – 100 Ω	DCLK_B		494.91
D_BN(4)	AG9	Input	LVC MOS	DDR	Differentially terminated – 100 Ω	DCLK_B		222.67
D_BN(5)	AE11	Input	LVC MOS	DDR	Differentially terminated – 100 Ω	DCLK_B		205.45
D_BN(6)	AH10	Input	LVC MOS	DDR	Differentially terminated – 100 Ω	DCLK_B		309.05
D_BN(7)	AF10	Input	LVC MOS	DDR	Differentially terminated – 100 Ω	DCLK_B		285.62
D_BN(8)	AK8	Input	LVC MOS	DDR	Differentially terminated – 100 Ω	DCLK_B		483.58
D_BN(9)	AG5	Input	LVC MOS	DDR	Differentially terminated – 100 Ω	DCLK_B		711.58
D_BN(10)	AL11	Input	LVC MOS	DDR	Differentially terminated – 100 Ω	DCLK_B		462.21
D_BN(11)	AE15	Input	LVC MOS	DDR	Differentially terminated – 100 Ω	DCLK_B		74.39
D_BN(12)	AH14	Input	LVC MOS	DDR	Differentially terminated – 100 Ω	DCLK_B		194.26
D_BN(13)	AF14	Input	LVC MOS	DDR	Differentially terminated – 100 Ω	DCLK_B		156
D_BN(14)	AJ17	Input	LVC MOS	DDR	Differentially terminated – 100 Ω	DCLK_B		247.9
D_BN(15)	AD16	Input	LVC MOS	DDR	Differentially terminated – 100 Ω	DCLK_B		111.52
D_BP(0)	AH4	Input	LVC MOS	DDR	Differentially terminated – 100 Ω	DCLK_B		525.02
D_BP(1)	AD10	Input	LVC MOS	DDR	Differentially terminated – 100 Ω	DCLK_B		190.61
D_BP(2)	AJ3	Input	LVC MOS	DDR	Differentially terminated – 100 Ω	DCLK_B		524.22
D_BP(3)	AE5	Input	LVC MOS	DDR	Differentially terminated – 100 Ω	DCLK_B	476.07	
D_BP(4)	AG11	Input	LVC MOS	DDR	Differentially terminated – 100 Ω	DCLK_B	222.8	
D_BP(5)	AE9	Input	LVC MOS	DDR	Differentially terminated – 100 Ω	DCLK_B	219.48	
D_BP(6)	AH8	Input	LVC MOS	DDR	Differentially terminated – 100 Ω	DCLK_B	306.55	
D_BP(7)	AF8	Input	LVC MOS	DDR	Differentially terminated – 100 Ω	DCLK_B	298.04	
D_BP(8)	AK10	Input	LVC MOS	DDR	Differentially terminated – 100 Ω	DCLK_B	480.31	

**Pin Functions (continued)**

PIN <sup>(1)</sup>		TYPE (I/O/P)	SIGNAL	DATA RATE <sup>(2)</sup>	INTERNAL TERM <sup>(3)</sup>	CLOCK	DESCRIPTION	TRACE (MILS)
NAME	NO.							
D_BP(9)	AG3	Input	LVC MOS	DDR	Differentially terminated – 100 Ω	DCLK_B	Input data bus B (2x LVDS)	727.18
D_BP(10)	AL9	Input	LVC MOS	DDR	Differentially terminated – 100 Ω	DCLK_B		461.02
D_BP(11)	AD14	Input	LVC MOS	DDR	Differentially terminated – 100 Ω	DCLK_B		71.35
D_BP(12)	AH16	Input	LVC MOS	DDR	Differentially terminated – 100 Ω	DCLK_B		197.69
D_BP(13)	AF16	Input	LVC MOS	DDR	Differentially terminated – 100 Ω	DCLK_B		150.38
D_BP(14)	AJ15	Input	LVC MOS	DDR	Differentially terminated – 100 Ω	DCLK_B		243.14
D_BP(15)	AE17	Input	LVC MOS	DDR	Differentially terminated – 100 Ω	DCLK_B		113.36
<b>DATA BUS C</b>								
D_CN(0)	B14	Input	LVC MOS	DDR	Differentially terminated – 100 Ω	DCLK_C	Input data bus C (2x LVDS)	459.04
D_CN(1)	E15	Input	LVC MOS	DDR	Differentially terminated – 100 Ω	DCLK_C		342.79
D_CN(2)	A17	Input	LVC MOS	DDR	Differentially terminated – 100 Ω	DCLK_C		456.22
D_CN(3)	G21	Input	LVC MOS	DDR	Differentially terminated – 100 Ω	DCLK_C		68.24
D_CN(4)	B20	Input	LVC MOS	DDR	Differentially terminated – 100 Ω	DCLK_C		362.61
D_CN(5)	F20	Input	LVC MOS	DDR	Differentially terminated – 100 Ω	DCLK_C		163.07
D_CN(6)	D22	Input	LVC MOS	DDR	Differentially terminated – 100 Ω	DCLK_C		204.16
D_CN(7)	G23	Input	LVC MOS	DDR	Differentially terminated – 100 Ω	DCLK_C		105.59
D_CN(8)	B26	Input	LVC MOS	DDR	Differentially terminated – 100 Ω	DCLK_C		450.51
D_CN(9)	F28	Input	LVC MOS	DDR	Differentially terminated – 100 Ω	DCLK_C		302.04
D_CN(10)	C29	Input	LVC MOS	DDR	Differentially terminated – 100 Ω	DCLK_C		429.8
D_CN(11)	G27	Input	LVC MOS	DDR	Differentially terminated – 100 Ω	DCLK_C		317.1
D_CN(12)	D26	Input	LVC MOS	DDR	Differentially terminated – 100 Ω	DCLK_C		276.76
D_CN(13)	H28	Input	LVC MOS	DDR	Differentially terminated – 100 Ω	DCLK_C		186.78
D_CN(14)	E29	Input	LVC MOS	DDR	Differentially terminated – 100 Ω	DCLK_C		311.3
D_CN(15)	J29	Input	LVC MOS	DDR	Differentially terminated – 100 Ω	DCLK_C		262.62
D_CP(0)	B16	Input	LVC MOS	DDR	Differentially terminated – 100 Ω	DCLK_C		463.64
D_CP(1)	E17	Input	LVC MOS	DDR	Differentially terminated – 100 Ω	DCLK_C	347.65	
D_CP(2)	A15	Input	LVC MOS	DDR	Differentially terminated – 100 Ω	DCLK_C	456.45	
D_CP(3)	H20	Input	LVC MOS	DDR	Differentially terminated – 100 Ω	DCLK_C	67.72	
D_CP(4)	B22	Input	LVC MOS	DDR	Differentially terminated – 100 Ω	DCLK_C	362.76	
D_CP(5)	F22	Input	LVC MOS	DDR	Differentially terminated – 100 Ω	DCLK_C	161.69	

**Pin Functions (continued)**

PIN <sup>(1)</sup>		TYPE (I/O/P)	SIGNAL	DATA RATE <sup>(2)</sup>	INTERNAL TERM <sup>(3)</sup>	CLOCK	DESCRIPTION	TRACE (MILS)
NAME	NO.							
D_CP(6)	D20	Input	LVC MOS	DDR	Differentially terminated – 100 Ω	DCLK_C	Input data bus C (2x LVDS)	195.09
D_CP(7)	H22	Input	LVC MOS	DDR	Differentially terminated – 100 Ω	DCLK_C		104.86
D_CP(8)	B28	Input	LVC MOS	DDR	Differentially terminated – 100 Ω	DCLK_C		451.41
D_CP(9)	F26	Input	LVC MOS	DDR	Differentially terminated – 100 Ω	DCLK_C		294.22
D_CP(10)	C27	Input	LVC MOS	DDR	Differentially terminated – 100 Ω	DCLK_C		429.68
D_CP(11)	G29	Input	LVC MOS	DDR	Differentially terminated – 100 Ω	DCLK_C		314.98
D_CP(12)	D28	Input	LVC MOS	DDR	Differentially terminated – 100 Ω	DCLK_C		276.04
D_CP(13)	H26	Input	LVC MOS	DDR	Differentially terminated – 100 Ω	DCLK_C		186.25
D_CP(14)	E27	Input	LVC MOS	DDR	Differentially terminated – 100 Ω	DCLK_C		312.07
D_CP(15)	J27	Input	LVC MOS	DDR	Differentially terminated – 100 Ω	DCLK_C		262.94
<b>DATA BUS D</b>								
D_DN(0)	AK14	Input	LVC MOS	DDR	Differentially terminated – 100 Ω	DCLK_D	Input data bus D (2x LVDS)	492.53
D_DN(1)	AG15	Input	LVC MOS	DDR	Differentially terminated – 100 Ω	DCLK_D		342.78
D_DN(2)	AL17	Input	LVC MOS	DDR	Differentially terminated – 100 Ω	DCLK_D		491.83
D_DN(3)	AE21	Input	LVC MOS	DDR	Differentially terminated – 100 Ω	DCLK_D		74.24
D_DN(4)	AK20	Input	LVC MOS	DDR	Differentially terminated – 100 Ω	DCLK_D		356.23
D_DN(5)	AF20	Input	LVC MOS	DDR	Differentially terminated – 100 Ω	DCLK_D		163.07
D_DN(6)	AH22	Input	LVC MOS	DDR	Differentially terminated – 100 Ω	DCLK_D		204.16
D_DN(7)	AE23	Input	LVC MOS	DDR	Differentially terminated – 100 Ω	DCLK_D		105.59
D_DN(8)	AK26	Input	LVC MOS	DDR	Differentially terminated – 100 Ω	DCLK_D		450.51
D_DN(9)	AF28	Input	LVC MOS	DDR	Differentially terminated – 100 Ω	DCLK_D		302.04
D_DN(10)	AJ29	Input	LVC MOS	DDR	Differentially terminated – 100 Ω	DCLK_D		429.8
D_DN(11)	AE27	Input	LVC MOS	DDR	Differentially terminated – 100 Ω	DCLK_D		298.87



**Pin Functions (continued)**

PIN <sup>(1)</sup>		TYPE (I/O/P)	SIGNAL	DATA RATE <sup>(2)</sup>	INTERNAL TERM <sup>(3)</sup>	CLOCK	DESCRIPTION	TRACE (MILS)
NAME	NO.							
D_DN(12)	AH26	Input	LVC MOS	DDR	Differentially terminated – 100 Ω	DCLK_D	Input data bus D (2x LVDS)	276.76
D_DN(13)	AD28	Input	LVC MOS	DDR	Differentially terminated – 100 Ω	DCLK_D		186.78
D_DN(14)	AG29	Input	LVC MOS	DDR	Differentially terminated – 100 Ω	DCLK_D		311.3
D_DN(15)	AC29	Input	LVC MOS	DDR	Differentially terminated – 100 Ω	DCLK_D		262.62
D_DP(0)	AK16	Input	LVC MOS	DDR	Differentially terminated – 100 Ω	DCLK_D		495.13
D_DP(1)	AG17	Input	LVC MOS	DDR	Differentially terminated – 100 Ω	DCLK_D		342.47
D_DP(2)	AL15	Input	LVC MOS	DDR	Differentially terminated – 100 Ω	DCLK_D		492.06
D_DP(3)	AD20	Input	LVC MOS	DDR	Differentially terminated – 100 Ω	DCLK_D		67.72
D_DP(4)	AK22	Input	LVC MOS	DDR	Differentially terminated – 100 Ω	DCLK_D		356.37
D_DP(5)	AF22	Input	LVC MOS	DDR	Differentially terminated – 100 Ω	DCLK_D		161.98
D_DP(6)	AH20	Input	LVC MOS	DDR	Differentially terminated – 100 Ω	DCLK_D		195.09
D_DP(7)	AD22	Input	LVC MOS	DDR	Differentially terminated – 100 Ω	DCLK_D		102.86
D_DP(8)	AK28	Input	LVC MOS	DDR	Differentially terminated – 100 Ω	DCLK_D		451.41
D_DP(9)	AF26	Input	LVC MOS	DDR	Differentially terminated – 100 Ω	DCLK_D		296.7
D_DP(10)	AJ27	Input	LVC MOS	DDR	Differentially terminated – 100 Ω	DCLK_D		429.68
D_DP(11)	AE29	Input	LVC MOS	DDR	Differentially terminated – 100 Ω	DCLK_D		302.74
D_DP(12)	AH28	Input	LVC MOS	DDR	Differentially terminated – 100 Ω	DCLK_D		276.04
D_DP(13)	AD26	Input	LVC MOS	DDR	Differentially terminated – 100 Ω	DCLK_D	186.25	
D_DP(14)	AG27	Input	LVC MOS	DDR	Differentially terminated – 100 Ω	DCLK_D	312.07	
D_DP(15)	AC27	Input	LVC MOS	DDR	Differentially terminated – 100 Ω	DCLK_D	262.94	

**Pin Functions (continued)**

PIN <sup>(1)</sup>		TYPE (I/O/P)	SIGNAL	DATA RATE <sup>(2)</sup>	INTERNAL TERM <sup>(3)</sup>	CLOCK	DESCRIPTION	TRACE (MILS)
NAME	NO.							
<b>DATA CLOCKS</b>								
DCLK_AN	D10	Input	LVC MOS	—	Differentially terminated – 100 Ω	—	Input data bus A Clock (2x LVDS)	325.8
DCLK_AP	D8	Input	LVC MOS	—	Differentially terminated – 100 Ω	—		319.9
DCLK_BN	AJ11	Input	LVC MOS	—	Differentially terminated – 100 Ω	—	Input data bus B Clock (2x LVDS)	318.92
DCLK_BP	AJ9	Input	LVC MOS	—	Differentially terminated – 100 Ω	—		318.74
DCLK_CN	C23	Input	LVC MOS	—	Differentially terminated – 100 Ω	—	Input data bus C Clock (2x LVDS)	252.01
DCLK_CP	C21	Input	LVC MOS	—	Differentially terminated – 100 Ω	—		241.18
DCLK_DN	AJ23	Input	LVC MOS	—	Differentially terminated – 100 Ω	—	Input data bus D Clock (2x LVDS)	252.01
DCLK_DP	AJ21	Input	LVC MOS	—	Differentially terminated – 100 Ω	—		241.18
<b>DATA CONTROL INPUTS</b>								
SCTRL_AN	J3	Input	LVC MOS	DDR	Differentially terminated – 100 Ω	DCLK_A	Serial control for data bus A (2x LVDS)	608.14
SCTRL_AP	J5	Input	LVC MOS	DDR	Differentially terminated – 100 Ω	DCLK_A		607.45
SCTRL_BN	AF4	Input	LVC MOS	DDR	Differentially terminated – 100 Ω	DCLK_B	Serial control for data bus B (2x LVDS)	698.12
SCTRL_BP	AF2	Input	LVC MOS	DDR	Differentially terminated – 100 Ω	DCLK_B		703.8
SCTRL_CN	E23	Input	LVC MOS	DDR	Differentially terminated – 100 Ω	DCLK_C	Serial control for data bus C (2x LVDS)	232.46
SCTRL_CP	E21	Input	LVC MOS	DDR	Differentially terminated – 100 Ω	DCLK_C		235.21
SCTRL_DN	AG23	Input	LVC MOS	DDR	Differentially terminated – 100 Ω	DCLK_D	Serial control for data bus D (2x LVDS)	235.53
SCTRL_DP	AG21	Input	LVC MOS	DDR	Differentially terminated – 100 Ω	DCLK_D		235.66
<b>SERIAL COMMUNICATION AND CONFIGURATION</b>								
SCPCLK	AE1	Input	LVC MOS	—	pull-down	—	Serial port clock	324.26
SCPDO	AC3	Output	LVC MOS	—	—	SCP_CLK	Serial port output	281.38
SCPDI	AD2	Input	LVC MOS	—	pull-down	SCP_CLK	Serial port input	261.55
SCPEN	AD4	Input	LVC MOS	—	pull-down	SCP_CLK	Serial port enable	184.86
PWRDN	B4	Input	LVC MOS	—	pull-down	—	Device reset	458.78
MODE_A	J1	Input	LVC MOS	—	pull-down	—	Data bandwidth mode select	471.57
MODE_B	G1	Input	LVC MOS	—	pull-down	—		521.99

**Pin Functions (continued)**

PIN <sup>(1)</sup>		TYPE (I/O/P)	SIGNAL	DATA RATE <sup>(2)</sup>	INTERNAL TERM <sup>(3)</sup>	CLOCK	DESCRIPTION	TRACE (MILS)
NAME	NO.							
<b>MICROMIRROR CLOCKING PULSE (BIAS RESET)</b>								
MBRST(0)	L5	Input	Analog	—	—	—	Micromirror clocking pulse reset MBRST signals clock micromirrors into state of LVCMOS memory cell associated with each mirror.	898.97
MBRST(1)	M28	Input	Analog	—	—	—		621.98
MBRST(2)	P4	Input	Analog	—	—	—		846.88
MBRST(3)	P30	Input	Analog	—	—	—		784.18
MBRST(4)	L3	Input	Analog	—	—	—		763.34
MBRST(5)	P28	Input	Analog	—	—	—		749.61
MBRST(6)	P2	Input	Analog	—	—	—		878.25
MBRST(7)	T28	Input	Analog	—	—	—		783.83
MBRST(8)	M4	Input	Analog	—	—	—		969.36
MBRST(9)	L29	Input	Analog	—	—	—		621.24
MBRST(10)	T4	Input	Analog	—	—	—		918.43
MBRST(11)	N29	Input	Analog	—	—	—		685.14
MBRST(12)	N3	Input	Analog	—	—	—		812.31
MBRST(13)	L27	Input	Analog	—	—	—		591.89
MBRST(14)	R3	Input	Analog	—	—	—		878.5
MBRST(15)	V28	Input	Analog	—	—	—		660.15
MBRST(16)	V4	Input	Analog	—	—	—		848.64
MBRST(17)	R29	Input	Analog	—	—	—		796.31
MBRST(18)	Y4	Input	Analog	—	—	—		715
MBRST(19)	AA27	Input	Analog	—	—	—		604.35
MBRST(20)	W3	Input	Analog	—	—	—		832.39
MBRST(21)	W27	Input	Analog	—	—	—		675.21
MBRST(22)	AA3	Input	Analog	—	—	—		861.18
MBRST(23)	W29	Input	Analog	—	—	—		662.66
MBRST(24)	U5	Input	Analog	—	—	—		850.06
MBRST(25)	U29	Input	Analog	—	—	—		726.56
MBRST(26)	Y2	Input	Analog	—	—	—		861.48
MBRST(27)	AA29	Input	Analog	—	—	—		683.83
MBRST(28)	U3	Input	Analog	—	—	—		878.5
MBRST(29)	Y30	Input	Analog	—	—	—	789.2	
<b>POWER</b>								
VCC	A3, A5, A7, A9, A11, A13, A21, A23, A25, A27, A29, B2,	Power	Analog	—	—	—	Power for LVCMOS logic	—
	C1, C31, E31, G31, J31, K2, L31, N31, R31, U31, W31,							
	AA31, AC1, AC31, AE31, AG1, AG31, AJ31, AK2,							
	AK30, AL3, AL5, AL7, AL19, AL21, AL23, AL25, AL27							
VCC1	H6, H12, H18, H24, M6, M26, P6, P26, T6, T26, V6, V26, Y6, Y26, AD6, AD12, AD18, AD24	Power	Analog	—	—	—	Power supply for LVDS Interface	—

**Pin Functions (continued)**

PIN <sup>(1)</sup>		TYPE (I/O/P)	SIGNAL	DATA RATE <sup>(2)</sup>	INTERNAL TERM <sup>(3)</sup>	CLOCK	DESCRIPTION	TRACE (MILS)
NAME	NO.							
VCC2	L1, N1, R1, U1, W1, AA1	Power	Analog	—	—	—	Power for high voltage CMOS logic	—
VSS	A1, B12, B18, B24, B30, C7, C13, C19, C25, D6, D12,  D18, D24, D30, E1, E7, E13, E19, E25, F6, F12, F18, F24,  F30, G7, G13, G19, G25, K4, K6, K26, K28, K30, M2, M30,  N5, N27, R5, T2, T30, U27, V2, V30, W5, Y28, AB2, AB4,  AB6, AB26, AB28, AB30, AD30, AE7, AE13, AE19,  AE25, AF6, AF12, AF18, AF24, AF30, AG7, AG13,  AG19, AG25, AH6, AH12, AH18, AH24, AH30, AJ1,  AJ7, AJ13, AJ19, AJ25, AK6, AK12, AK18, AL29	Power	Analog	—	—	—	Common return for all power inputs	—
<b>RESERVED SIGNALS (NOT FOR USE IN SYSTEM)</b>								
RESERVED_FC	J7	Input	LVC MOS	—	pull-down	—	Pins should be connected to VSS	—
RESERVED_FD	J9	Input	LVC MOS	—	pull-down	—		—
RESERVED_PFE	J11	Input	LVC MOS	—	pull-down	—		—
RESERVED_STM	AC7	Input	LVC MOS	—	pull-down	—		—
RESERVED_AE	C3	Input	LVC MOS	—	pull-down	—		—
NO_CONNECT	A19, B6, C5, H30, J13, J15, J17, J19, J21, J23, J25, R27,  AA5, AC11, AC13, AC15, AC17, AC19, AC21, AC23,  AC25, AC5, AC9, AK24, AK4, AL13	—	—	—	—	—	No connection (any connection to these terminals may result in undesirable effects)	—

## 7 Specifications

### 7.1 Absolute Maximum Ratings

over operating free-air temperature (unless otherwise noted). <sup>(1)</sup>

		MIN	MAX	UNIT
<b>ELECTRICAL</b>				
V <sub>CC</sub>	Voltage applied to V <sub>CC</sub> <sup>(2) (3)</sup>	-0.5	4	V
V <sub>CCI</sub>	Voltage applied to V <sub>CCI</sub> <sup>(2) (3)</sup>	-0.5	4	V
V <sub>CC2</sub>	Voltage applied to V <sub>VCC2</sub> <sup>(2) (3) (4)</sup>	-0.5	9	V
V <sub>MBRST</sub>	Clocking pulse waveform voltage applied to MBRST[29:0] input pins (supplied by DLPA200s)	-28	28	V
V <sub>CC</sub> - V <sub>CCI</sub>	Supply voltage delta (absolute value) <sup>(4)</sup>		0.3	V
	Voltage applied to all other input terminals <sup>(2)</sup>	-0.5	V <sub>CC</sub> + 0.3	V
V <sub>ID</sub>	Maximum differential voltage, damage can occur to internal termination resistor if exceeded, see <a href="#">Figure 3</a>		700	mV
	Current required from a high-level output, V <sub>OH</sub> = 2.4 V		-20	mA
	Current required from a low-level output, V <sub>OL</sub> = 0.4 V		15	mA
<b>ENVIRONMENTAL</b>				
T <sub>C</sub>	Case temperature – operational <sup>(5)</sup>	20	70	°C
	Case temperature – non-operational <sup>(5)</sup>	-40	80	°C
T <sub>GRADIENT</sub>	Device temperature gradient – operational <sup>(6)</sup>		10	°C
RH	Relative humidity (non-condensing)		95	%RH

- (1) Stresses beyond those listed under [Recommended Operating Conditions](#) may cause permanent damage to the device. These are stress ratings only, which do not imply functional operation of the device at these or any other conditions beyond those indicated under [Recommended Operating Conditions](#). Exposure to absolute-maximum-rated conditions for extended periods may affect device reliability.
- (2) All voltages referenced to V<sub>SS</sub> (ground).
- (3) Voltages V<sub>CC</sub>, V<sub>CCI</sub>, and V<sub>CC2</sub> are required for proper DMD operation.
- (4) Exceeding the recommended allowable absolute voltage difference between V<sub>CC</sub> and V<sub>CCI</sub> may result in excess current draw. The difference between V<sub>CC</sub> and V<sub>CCI</sub>, |V<sub>CC</sub> - V<sub>CCI</sub>|, should be less than the specified limit.
- (5) DMD Temperature is the worst-case of any test point shown in [Case Temperature](#), or the active array as calculated by the [Micromirror Array Temperature Calculation](#).
- (6) As either measured, predicted, or both between any two points - measured on the exterior of the package, or as predicted at any point inside the micromirror array cavity. Refer to [Case Temperature](#) and [Micromirror Array Temperature Calculation](#).

### 7.2 Storage Conditions

applicable before the DMD is installed in the final product

		MIN	MAX	UNIT
T <sub>DMD</sub>	Storage temperature	-40	80	°C
RH	Storage humidity (non-condensing)		95	%RH

### 7.3 ESD Ratings

			VALUE	UNIT
V <sub>ESD</sub>	Electrostatic discharge	Human body model (HBM), per ANSI/ESDA/JEDEC JS-001 <sup>(1)</sup>	±2000	V
		All pins except MBRST[29:0] MBRST[29:0] pins	±250	

- (1) JEDEC document JEP155 states that 500-V HBM allows safe manufacturing with a standard ESD control process. Manufacturing with less than 500-V HBM is possible if necessary precautions are taken.

## 7.4 Recommended Operating Conditions

 over operating free-air temperature range (unless otherwise noted). <sup>(1)</sup>

		MIN	NOM	MAX	UNIT	
<b>ELECTRICAL</b> <sup>(2) (3)</sup>						
V <sub>CC</sub>	Supply voltage for LVCMOS core logic	3.0	3.3	3.6	V	
V <sub>CCI</sub>	Supply voltage for LVDS receivers	3.0	3.3	3.6	V	
V <sub>CC2</sub>	Mirror electrode and HVCMOS supply voltage	8.25	8.5	8.75	V	
V <sub>MBRST</sub>	Clocking Pulse Waveform Voltage applied to MBRST[29:0] Input Pins (supplied by DLPA200s)	-27		26.5	V	
V <sub>CC</sub> – V <sub>CCI</sub>	Supply voltage delta (absolute value) <sup>(4)</sup>			0.3	V	
<b>ENVIRONMENTAL</b> <sup>(5)</sup>						
Illumination power density <sup>(6)</sup>		<400 nm <sup>(7)</sup>		0.68	mW/cm <sup>2</sup>	
		400 to 420 nm <sup>(8)</sup>		11	W/cm <sup>2</sup>	
				26.6	W	
		420 to 700 nm		Thermally limited <sup>(8)</sup>		W/cm <sup>2</sup>
		>700 nm				10
T <sub>C</sub>	Operating case temperature <sup>(9)</sup> : Thermal test point 1 and array <sup>(10)</sup>		20	25-45	65 <sup>(10)</sup>	°C
	Operating case temperature <sup>(9)</sup> : Thermal test points 2, and 3 <sup>(10)</sup>		20	25-45	70 <sup>(10)</sup>	°C
T <sub>GRADIENT</sub>	Device temperature gradient – operational <sup>(11)</sup>				10	°C
RH	Relative humidity (non-condensing)		0		95	%RH

- (1) The functional performance of the device specified in this data sheet is achieved when operating the device within the limits defined by the *Recommended Operating Conditions*. No level of performance is implied when operating the device above or below the *Recommended Operating Conditions* limits.
- (2) Voltages V<sub>CC</sub>, V<sub>CC2</sub>, and V<sub>CCI</sub> are required for proper DMD operation. V<sub>SS</sub> must also be connected.
- (3) All voltages are referenced to common ground VSS.
- (4) Exceeding the recommended allowable absolute voltage difference between V<sub>CC</sub> and V<sub>CCI</sub> may result in excess current draw. The difference between V<sub>CC</sub> and V<sub>CCI</sub>, |V<sub>CC</sub> – V<sub>CCI</sub>|, should be less than the specified limit.
- (5) Optimal, long-term performance and optical efficiency of the Digital Micromirror Device (DMD) can be affected by various application parameters, including illumination spectrum, illumination power density, micromirror landed duty-cycle, ambient temperature (storage and operating), DMD temperature, ambient humidity (storage and operating), and power on or off duty cycle. TI recommends that application-specific effects be considered as early as possible in the design cycle.
- (6) Total integrated illumination power density, above or below the indicated wavelength threshold or in the indicated wavelength range.
- (7) The maximum operating conditions for operating temperature and illumination power density for wavelengths <400 nm should not be implemented simultaneously.
- (8) Also limited by the resulting micromirror array temperature. Refer to [Case Temperature](#) and [Micromirror Array Temperature Calculation](#) for information related to calculating the micromirror array temperature.
- (9) In some applications, the total DMD heat load can be dominated by the amount of incident light energy absorbed. See [Micromirror Array Temperature Calculation](#) for further details.
- (10) See the [Micromirror Array Temperature Calculation](#) for thermal test point locations, package thermal resistance, and device temperature calculation.
- (11) As either measured, predicted, or both between any two points - measured on the exterior of the package, or as predicted at any point inside the micromirror array cavity.

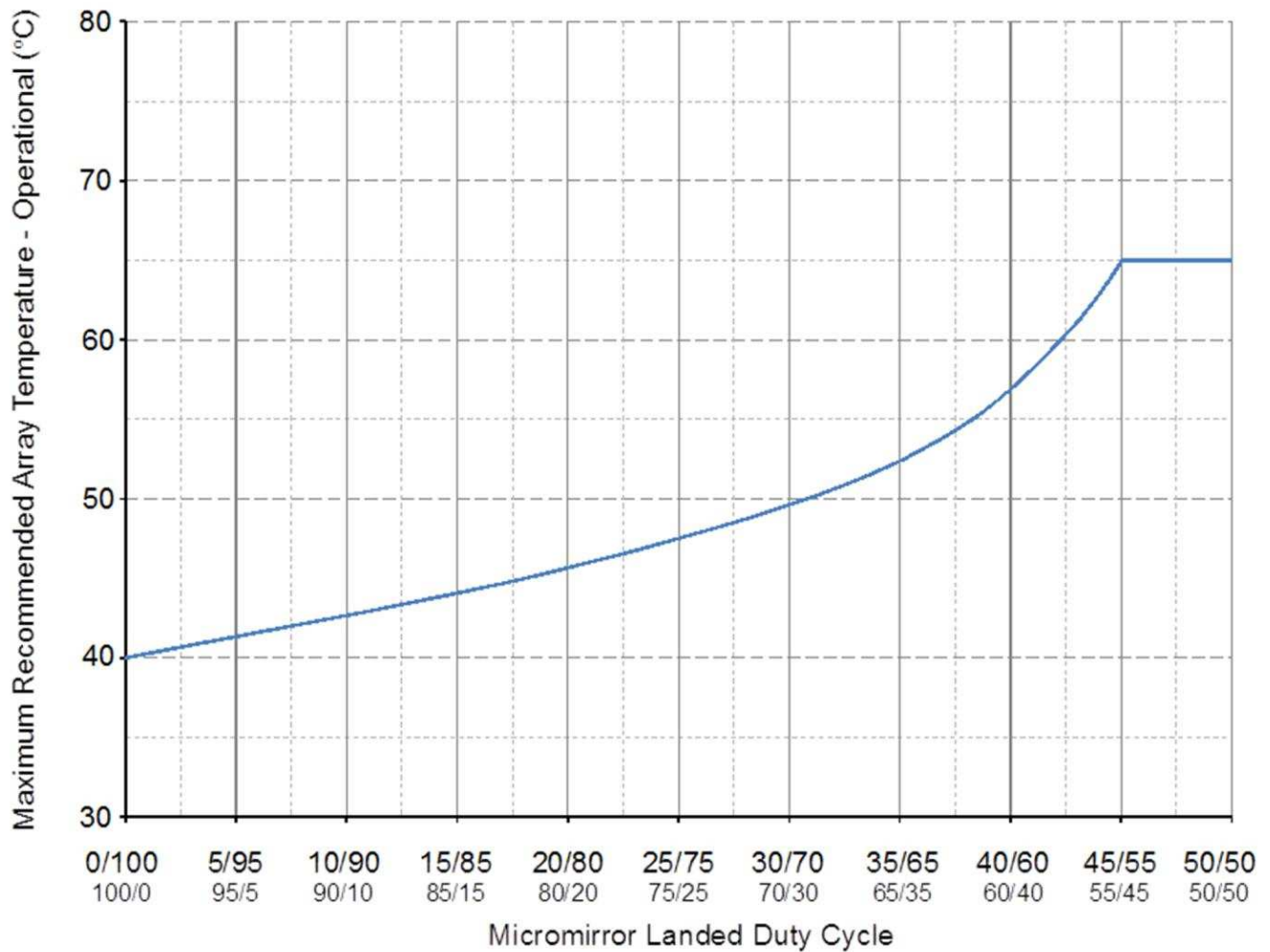

Figure 1. Max Recommended DMD Temperature – Derating Curve

### 7.5 Thermal Information

THERMAL METRIC <sup>(1)</sup> <sup>(2)</sup>	DLP9500	
	FLN (LCCC)	UNIT
	355 PINS	
Active micromirror array resistance to TC2	0.5	°C/W

- (1) The DMD is designed to conduct absorbed and dissipated heat to the back of the package where it can be removed by an appropriate heat sink. The heat sink and cooling system must be capable of maintaining the package within the temperature range specified in the [Recommended Operating Conditions](#). The total heat load on the DMD is largely driven by the incident light absorbed by the active area; although other contributions include light energy absorbed by the window aperture and electrical power dissipation of the array. Optical systems should be designed to minimize the light energy falling outside the window clear aperture since any additional thermal load in this area can significantly degrade the reliability of the device.
- (2) For more information about traditional and new thermal metrics, see the *Semiconductor and IC Package Thermal Metrics* application report, [SPRA953](#).

## 7.6 Electrical Characteristics

over the range of recommended supply voltage and recommended case operating temperature (unless otherwise noted); under recommended operating conditions

PARAMETER		TEST CONDITIONS	MIN	TYP	MAX	UNIT
V <sub>OH</sub>	High-level output voltage <sup>(1)</sup> , See <a href="#">Figure 11</a>	V <sub>CC</sub> = 3 V, I <sub>OH</sub> = –20 mA	2.4			V
V <sub>OL</sub>	Low-level output voltage <sup>(1)</sup> , See <a href="#">Figure 11</a>	V <sub>CC</sub> = 3.6 V, I <sub>OH</sub> = 15 mA			0.4	V
V <sub>MBRST</sub>	Clocking pulse waveform applied to MBRST[29:0] input pins (supplied by DLPA200s)		–27		26.5	V
I <sub>OZ</sub>	High-impedance output current <sup>(1)</sup>	V <sub>CC</sub> = 3.6 V			10	μA
I <sub>OH</sub>	High-level output current <sup>(1)</sup>	V <sub>OH</sub> = 2.4 V, V <sub>CC</sub> ≥ 3 V			–20	mA
		V <sub>OH</sub> = 1.7 V, V <sub>CC</sub> ≥ 2.25 V			–15	
I <sub>OL</sub>	Low-level output current <sup>(1)</sup>	V <sub>OL</sub> = 0.4 V, V <sub>CC</sub> ≥ 3 V			15	mA
		V <sub>OL</sub> = 0.4 V, V <sub>CC</sub> ≥ 2.25 V			14	
V <sub>IH</sub>	High-level input voltage <sup>(1)</sup>		1.7		V <sub>CC</sub> + .3	V
V <sub>IL</sub>	Low-level input voltage <sup>(1)</sup>		–0.3		0.7	V
I <sub>IL</sub>	Low-level input current <sup>(1)</sup>	V <sub>CC</sub> = 3.6 V, V <sub>I</sub> = 0 V			–60	μA
I <sub>IH</sub>	High-level input current <sup>(1)</sup>	V <sub>CC</sub> = 3.6 V, V <sub>I</sub> = V <sub>CC</sub>			60	μA
I <sub>CC</sub>	Current into V <sub>CC</sub> pin	V <sub>CC</sub> = 3.6 V,			2990	mA
I <sub>CCI</sub>	Current into V <sub>OFFSET</sub> pin <sup>(2)</sup>	V <sub>CCI</sub> = 3.6 V			910	mA
I <sub>CC2</sub>	Current into V <sub>CC2</sub> pin	V <sub>CC2</sub> = 8.75 V			25	mA
P <sub>D</sub>	Power dissipation			4.4		W
Z <sub>IN</sub>	Internal differential impedance		95		105	Ω
Z <sub>LINE</sub>	Line differential impedance (PWB, trace)		90	100	110	Ω
C <sub>I</sub>	Input capacitance <sup>(1)</sup>	f = 1 MHz			10	pF
C <sub>O</sub>	Output capacitance <sup>(1)</sup>	f = 1 MHz			10	pF
C <sub>IM</sub>	Input capacitance for MBRST[29:0] pins	f = 1 MHz	270		355	pF

(1) Applies to LVCMOS pins only.

(2) Exceeding the maximum allowable absolute voltage difference between V<sub>CC</sub> and V<sub>CCI</sub> may result in excess current draw. (See [Absolute Maximum Ratings](#) for details).



### 7.7 LVDS Timing Requirements

over operating free-air temperature range (unless otherwise noted); see Figure 2

		MIN	NOM	MAX	UNIT
$f_{DCLK\_x}$	DCLK_x clock frequency (where x = [A, B, C, or D])	200		400	MHz
$t_c$	Clock cycle - DLCK_x	2.5			ns
$t_w$	Pulse duration - DLCK_x		1.25		ns
$t_s$	Setup time - D_x[15:0] and SCTRL_x before DCLK_x	.35			ns
$t_h$	Hold time, D_x[15:0] and SCTRL_x after DCLK_x	.35			ns
$t_{skew}$	Skew between any two buses (A ,B, C, and D)	-1.25		1.25	ns

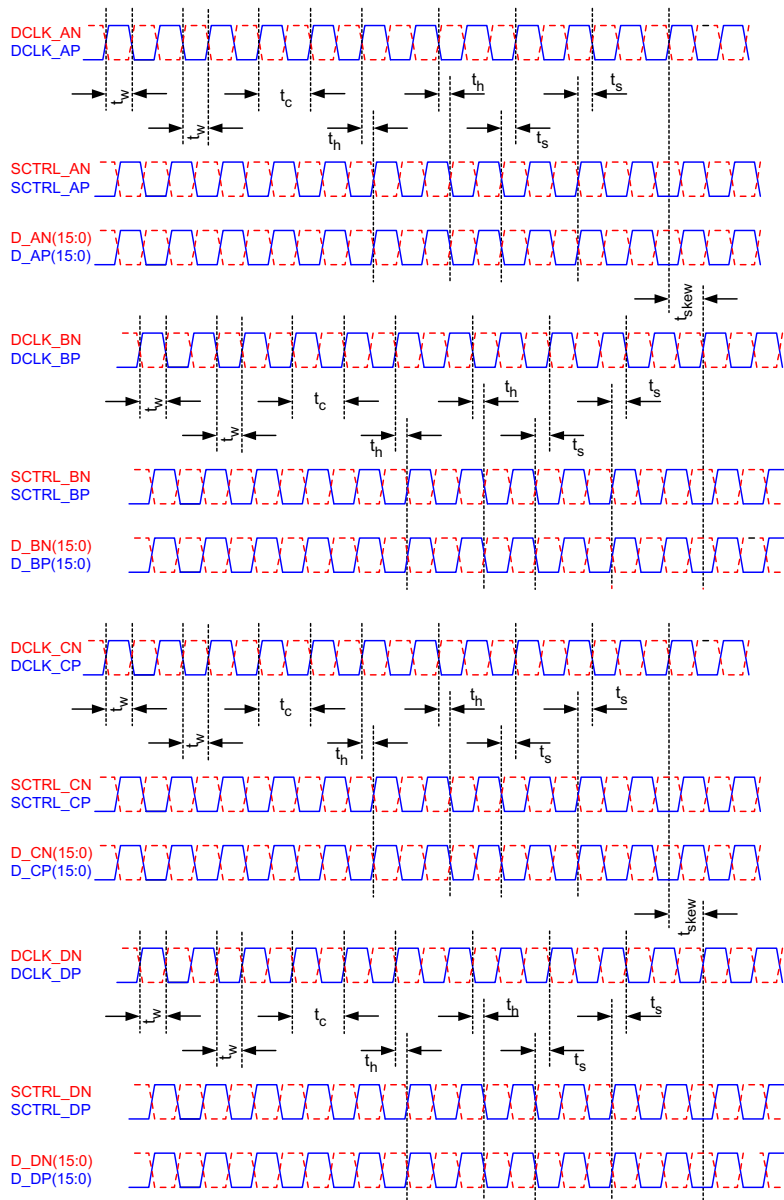
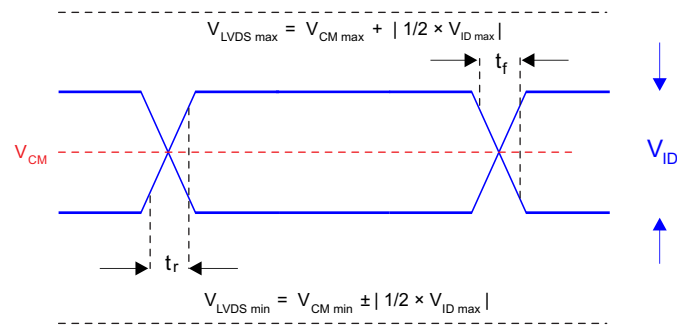

Figure 2. LVDS Timing Waveforms

## 7.8 LVDS Waveform Requirements

over operating free-air temperature range (unless otherwise noted); see [Figure 3](#)

		MIN	NOM	MAX	UNIT
$ V_{ID} $	Input differential voltage (absolute difference)	100	400	600	mV
$V_{CM}$	Common mode voltage		1200		mV
$V_{LVDS}$	LVDS voltage	0		2000	mV
$t_r$	Rise time (20% to 80%)	100		400	ps
$t_f$	Fall time (80% to 20%)	100		400	ps



**Figure 3. LVDS Waveform Requirements**

### 7.9 Serial Control Bus Timing Requirements

over operating free-air temperature range (unless otherwise noted); see [Figure 4](#) and [Figure 5](#)

		MIN	NOM	MAX	UNIT
$f_{SCP\_CLK}$	SCP clock frequency	50		500	kHz
$t_{SCP\_SKEW}$	Time between valid SCP_DI and rising edge of SCP_CLK	-300		300	ns
$t_{SCP\_DELAY}$	Time between valid SCP_DO and rising edge of SCP_CLK			960	ns
$t_{SCP\_EN}$	Time between falling edge of $\overline{SCP\_EN}$ and the first rising edge of SCP_CLK	30			ns
$t_{SCP}$	Rise time for SCP signals			200	ns
$t_{f\_SCP}$	Fall time for SCP signals			200	ns

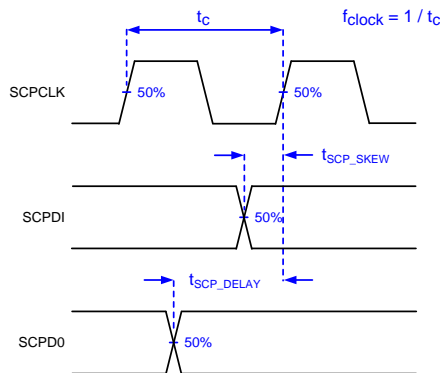

Figure 4. Serial Communications Bus Timing Parameters

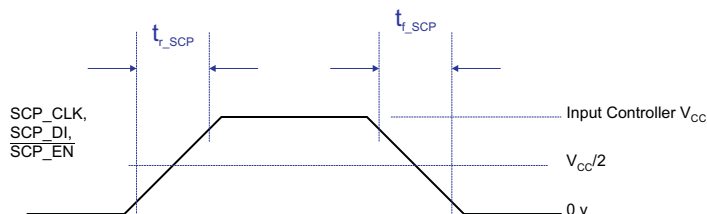
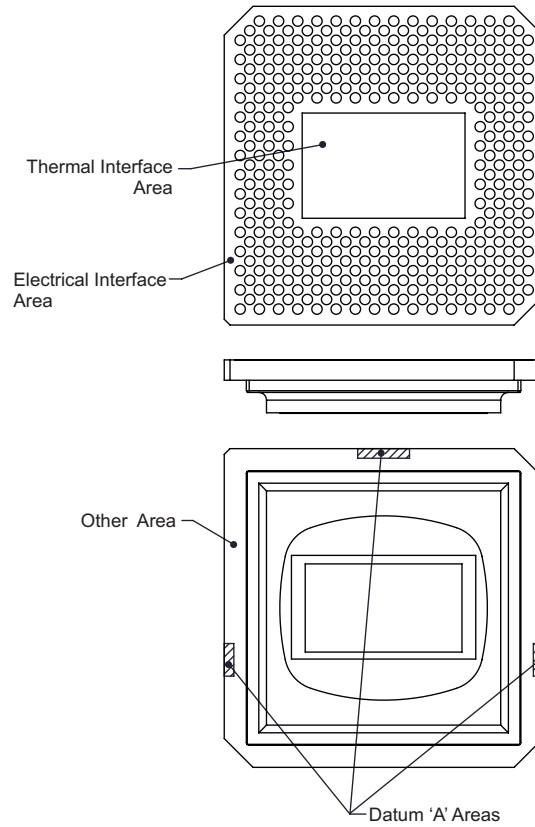

Figure 5. Serial Communications Bus Waveform Requirements

### 7.10 Systems Mounting Interface Loads

	PARAMETER	MIN	NOM	MAX	UNIT
Maximum system mounting interface load to be applied to the:	Thermal interface area (see <a href="#">Figure 6</a> )			156	N
	Electrical interface area (see <a href="#">Figure 6</a> )			1334	N
	Datum A Interface area (see <a href="#">Figure 6</a> )			712	N



**Figure 6. System Interface Loads**

### 7.11 Micromirror Array Physical Characteristics

See [Mechanical, Packaging, and Orderable Information](#) for additional details.

		VALUE	UNIT
M	Number of active micromirror columns <sup>(1)</sup>	1920	micromirrors
N	Number of active micromirror rows <sup>(1)</sup>	1080	micromirrors
P	Micromirror (pixel) pitch <sup>(1)</sup>	10.8	μm
	Micromirror active array width <sup>(1)</sup>	M × P	mm
	Micromirror active array height <sup>(1)</sup>	N × P	mm
	Micromirror array border <sup>(1)</sup> <sup>(2)</sup>	Pond of micromirrors (POM)	10
			micromirrors/side

- (1) See [Figure 7](#).
- (2) The structure and qualities of the border around the active array includes a band of partially functional micromirrors called the POM. These micromirrors are structurally and/or electrically prevented from tilting toward the bright or ON state, but still require an electrical bias to tilt toward OFF.

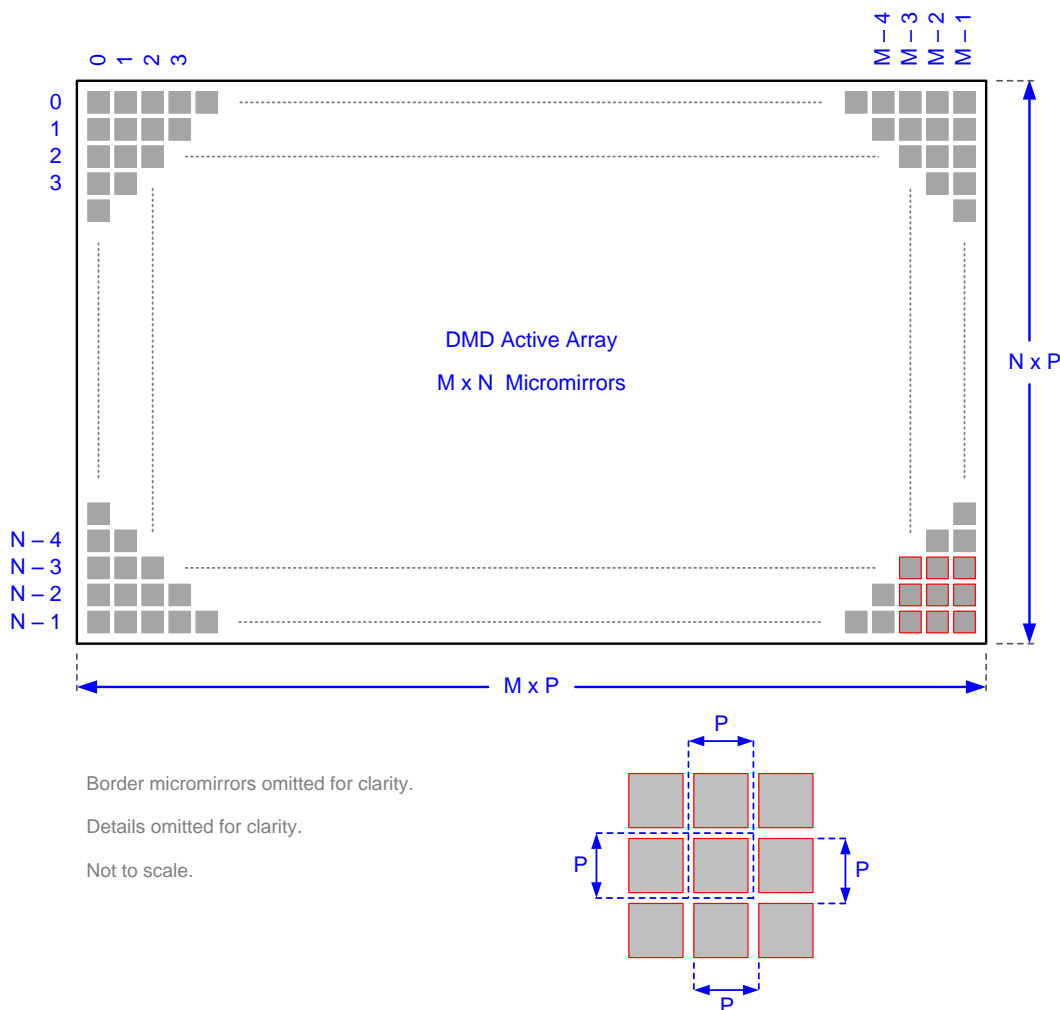

Refer to the [Micromirror Array Physical Characteristics](#) table for M, N, and P specifications.

**Figure 7. Micromirror Array Physical Characteristics**

## 7.12 Micromirror Array Optical Characteristics

TI assumes no responsibility for end-equipment optical performance. Achieving the desired end-equipment optical performance involves making trade-offs between numerous component and system design parameters. See the related application reports (listed in [Related Documentation](#)) for guidelines.

PARAMETER		TEST CONDITIONS	MIN	TYP	MAX	UNIT
a	Micromirror tilt angle	DMD parked state <sup>(1)</sup> <sup>(2)</sup> <sup>(3)</sup> , See <a href="#">Figure 12</a>		0		degrees
		DMD landed state <sup>(1)</sup> <sup>(4)</sup> <sup>(5)</sup> See <a href="#">Figure 12</a>		12		
$\beta$	Micromirror tilt angle variation <sup>(1)</sup> <sup>(4)</sup> <sup>(6)</sup> <sup>(7)</sup> <sup>(8)</sup>	See <a href="#">Figure 12</a>	-1		1	degrees
	Micromirror crossover time <sup>(9)</sup>			3		$\mu$ s
	Micromirror switching time <sup>(10)</sup>			13	22	$\mu$ s
	Array switching time at 400 MHz with global reset <sup>(11)</sup>		56			$\mu$ s
	Non-operating micromirrors <sup>(12)</sup>	Non-adjacent micromirrors			10	micromirrors
		Adjacent micromirrors			0	
	Orientation of the micromirror axis-of-rotation <sup>(13)</sup>	See <a href="#">Figure 12</a>	44	45	46	degrees

- (1) Measured relative to the plane formed by the overall micromirror array.
- (2) Parking the micromirror array returns all of the micromirrors to an essentially flat (0°) state (as measured relative to the plane formed by the overall micromirror array).
- (3) When the micromirror array is parked, the tilt angle of each individual micromirror is uncontrolled.
- (4) Additional variation exists between the micromirror array and the package datums, as shown in [Mechanical, Packaging, and Orderable Information](#).
- (5) When the micromirror array is landed, the tilt angle of each individual micromirror is dictated by the binary contents of the CMOS memory cell associated with each individual micromirror. A binary value of 1 results in a micromirror landing in a nominal angular position of +12°. A binary value of 0 results in a micromirror landing in a nominal angular position of -12°.
- (6) Represents the landed tilt angle variation relative to the nominal landed tilt angle.
- (7) Represents the variation that can occur between any two individual micromirrors, located on the same device or located on different devices.
- (8) For some applications, it is critical to account for the micromirror tilt angle variation in the overall system optical design. With some system optical designs, the micromirror tilt angle variation within a device may result in perceivable non-uniformities in the light field reflected from the micromirror array. With some system optical designs, the micromirror tilt angle variation between devices may result in colorimetry variations and/or system contrast variation.
- (9) Micromirror crossover time is the transition time from landed to landed during a crossover transition and primarily a function of the natural response time of the micromirrors.
- (10) Micromirror switching time is the time after a micromirror clocking pulse until the micromirrors can be addressed again. It included the micromirror settling time.
- (11) Array switching is controlled and coordinated by the DLPC410 (DLPS024) and DLPA200 (DLPS015). Nominal switching time depends on the system implementation and represents the time for the entire micromirror array to be refreshed (array loaded plus reset and mirror settling time).
- (12) Non-operating micromirror is defined as a micromirror that is unable to transition nominally from the -12° position to +12° or vice versa.
- (13) Measured relative to the package datums 'B' and 'C', shown in the [Mechanical, Packaging, and Orderable Information](#).

## Micromirror Array Optical Characteristics (continued)

TI assumes no responsibility for end-equipment optical performance. Achieving the desired end-equipment optical performance involves making trade-offs between numerous component and system design parameters. See the related application reports (listed in [Related Documentation](#)) for guidelines.

PARAMETER	TEST CONDITIONS	MIN	TYP	MAX	UNIT
Micromirror array optical efficiency <sup>(14)</sup> <sup>(15)</sup>	400 to 700 nm, with all micromirrors in the ON state		68%		

(14) The minimum or maximum DMD optical efficiency observed in a specific application depends on numerous application-specific design variables, such as:

- Illumination wavelength, bandwidth/line-width, degree of coherence
- Illumination angle, plus angle tolerance
- Illumination and projection aperture size, and location in the system optical path
- Illumination overfill of the DMD micromirror array
- Aberrations present in the illumination source and/or path
- Aberrations present in the projection path

The specified nominal DMD optical efficiency is based on the following use conditions:

- Visible illumination (400 to 700 nm)
- Input illumination optical axis oriented at 24° relative to the window normal
- Projection optical axis oriented at 0° relative to the window normal
- $f / 3$  illumination aperture
- $f / 2.4$  projection aperture

Based on these use conditions, the nominal DMD optical efficiency results from the following four components:

- Micromirror array fill factor: nominally 92%
- Micromirror array diffraction efficiency: nominally 86%
- Micromirror surface reflectivity: nominally 88%
- Window transmission: nominally 97% (single pass, through two surface transitions)

(15) Does not account for the effect of micromirror switching duty cycle, which is application dependent. Micromirror switching duty cycle represents the percentage of time that the micromirror is actually reflecting light from the optical illumination path to the optical projection path. This duty cycle depends on the illumination aperture size, the projection aperture size, and the micromirror array update rate.

## 7.13 Window Characteristics

PARAMETER <sup>(1)</sup>	TEST CONDITIONS	MIN	TYP	MAX	UNIT
Window material designation	Corning 7056				
Window refractive index	At wavelength 589 nm		1.487		
Window flatness <sup>(2)</sup>	Per 25 mm			4	fringes
Window artifact size	Within the Window Aperture <sup>(3)</sup>			400	μm
Window aperture	See <sup>(4)</sup>				
Illumination overfill	Refer to <a href="#">Illumination Overfill</a>				
Window transmittance, single-pass through both surfaces and glass <sup>(5)</sup>	At wavelength 405 nm. Applies to 0° and 24° AOI only.		95%		
	Minimum within the wavelength range 420 nm to 680 nm. Applies to all angles 0° to 30° AOI.		97%		
	Average over the wavelength range 420 nm to 680 nm. Applies to all angles 30° to 45° AOI.		97%		

(1) See [Window Characteristics and Optics](#) for more information.

(2) At a wavelength of 632.8 nm.

(3) See the [Mechanical, Packaging, and Orderable Information](#) section at the end of this document for details regarding the size and location of the window aperture.

(4) For details regarding the size and location of the window aperture, see the package mechanical characteristics listed in the Mechanical ICD in the Mechanical, Packaging, and Orderable Information section.

(5) See the TI application report [DLPA031, Wavelength Transmittance Considerations for DLP DMD Window](#).

## 7.14 Chipset Component Usage Specification

The DLP9500 is a component of one or more DLP chipsets. Reliable function and operation of the DLP9500 requires that it be used in conjunction with the other components of the applicable DLP chipset, including those components that contain or implement TI DMD control technology. TI DMD control technology is the TI technology and devices for operating or controlling a DLP DMD.

## 8 Detailed Description

### 8.1 Overview

Optically, the DLP9500 consists of 2,073,600 highly reflective, digitally switchable, micrometer-sized mirrors (micromirrors), organized in a two-dimensional array of 1920 micromirror columns by 1080 micromirror rows (). Each aluminum micromirror is approximately 10.8 microns in size (see the *Micromirror Pitch* in ) and is switchable between two discrete angular positions:  $-12^\circ$  and  $12^\circ$ . The angular positions are measured relative to a  $0^\circ$  flat state, which is parallel to the array plane (see [Figure 12](#)). The tilt direction is perpendicular to the hinge-axis, which is positioned diagonally relative to the overall array. The On State landed position is directed toward row 0, column 0 (upper left) corner of the device package (see the *Micromirror Hinge-Axis Orientation* in ). In the field of visual displays, the  $1920 \times 1080$  pixel resolution is referred to as 1080p.

Each individual micromirror is positioned over a corresponding CMOS memory cell. The angular position of a specific micromirror is determined by the binary state (logic 0 or 1) of the corresponding CMOS memory cell contents, after the mirror clocking pulse is applied. The angular position ( $-12^\circ$  or  $+12^\circ$ ) of the individual micromirrors changes synchronously with a micromirror clocking pulse, rather than being synchronous with the CMOS memory cell data update. Therefore, writing a logic 1 into a memory cell followed by a mirror clocking pulse will result in the corresponding micromirror switching to a  $12^\circ$  position. Writing a logic 0 into a memory cell followed by a mirror clocking pulse will result in the corresponding micromirror switching to a  $-12^\circ$  position.

Updating the angular position of the micromirror array consists of two steps. First, updating the contents of the CMOS memory. Second, application of a micromirror clocking pulse to all or a portion of the micromirror array (depending upon the configuration of the system). Micromirror clocking pulses are generated externally by two DLPA200s, with application of the pulses being coordinated by the DLPC410 controller.

Around the perimeter of the  $1920$  by  $1080$  array of micromirrors is a uniform band of border micromirrors. The border micromirrors are not user-addressable. The border micromirrors land in the  $-12^\circ$  position once power has been applied to the device. There are 10 border micromirrors on each side of the  $1920$  by  $1080$  active array.

[Figure 8](#) shows a DLPC410 and DLP9500 chipset block diagram. The DLPC410 and DLPA200s control and coordinate the data loading and micromirror switching for reliable DLP9500 operation. The DLPR410 is the programmed PROM required to properly configure the DLPC410 controller. For more information on the chipset components, see [Application and Implementation](#). For a typical system application using the DLP Discovery 4100 chipset including a DLP9500, see [Figure 18](#).

### 8.2 Functional Block Diagram

[Figure 8](#) shows a simplified system block diagram with the use of the DLPC410 with the following chipset components:

- DLPC410** Xilinx [XC5VLX30] FPGA configured to provide high-speed DMD data and control, and DLPA200 timing and control
- DLPR410** [XCF16PFSG48C] serial flash PROM contains startup configuration information (EEPROM)
- DLPA200** Two DMD micromirror drivers for the DLP9500 DMD
- DLP9500** Spatial light modulator (DMD)



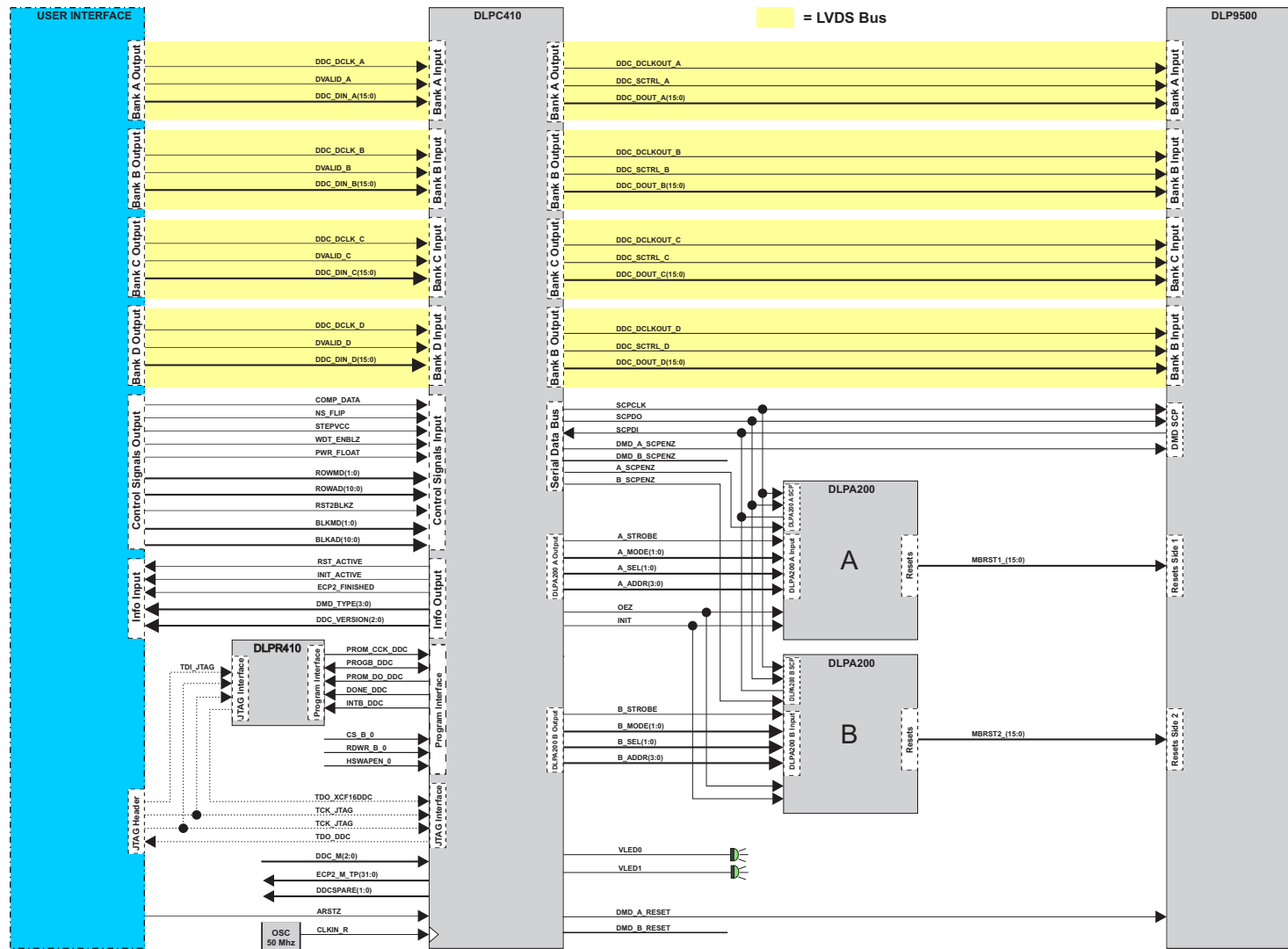

Figure 8. DLPC410, DLPA200, DLPR410, and DLP9500 Functional Block Diagram

## 8.3 Feature Description

**Table 1. DMD Overview**

DMD	ARRAY	SINGLE BLOCK MODE (Patterns/s)	GLOBAL RESET MODE (Patterns/s)	DATA RATE (Giga Pixels/s)	MIRROR PITCH
DLP9500 - 0.95" 1080p	1920 × 1080	23148	17857	48	10.8 μm

### 8.3.1 DLPC410 - Digital Controller for DLP Discovery 4100 chipset

The DLPC410 chipset includes the DLPC410 controller which provides a high-speed LVDS data and control interface for DMD control. This interface is also connected to a second FPGA used to drive applications (not included in the chipset). The DLPC410 generates DMD and DLPA200 initialization and control signals in response to the inputs on the control interface.

For more information, see the DLPC410 data sheet ([DLPS024](#)).

### 8.3.2 DLPA200 - DMD Micromirror Drivers

DLPA200 micromirror drivers provide the micromirror clocking pulse driver functions for the DMD. Two drivers are required for DLP9500.

The DLPA200 is designed to work with multiple DLP chipsets. Although the DLPA200 contains 16 MBSRT output pins, only 15 lines are used with the DLP9500 chipset. For more information see and the DLPA200 data sheet ([DLPS015](#)).

### 8.3.3 DLPR410 - PROM for DLP Discovery 4100 chipset

The DLPC410 controller is configured at startup from the DLPR410 PROM. The contents of this PROM can not be altered. For more information, see the DLPR410 data sheet ([DLPS027](#)) the DLPC410 data sheet ([DLPS024](#)).

### 8.3.4 DLP9500 - DLP 0.95 1080p 2xLVDS Type-A DMD 1080p DMD

#### 8.3.4.1 DLP9500 1080p Chipset Interfaces

This section will describe the interface between the different components included in the chipset. For more information on component interfacing, see [Application and Implementation](#).

##### 8.3.4.1.1 DLPC410 Interface Description

###### 8.3.4.1.1.1 DLPC410 IO

[Table 2](#) describes the inputs and outputs of the DLPC410 to the user. For more details on these signals, see the DLPC410 data sheet ([DLPS024](#)).

**Table 2. Input/Output Description**

PIN NAME	DESCRIPTION	I/O
ARST	Asynchronous active low reset	I
CLKIN_R	Reference clock, 50 MHz	I
DIN_[A,B,C,D](15:0)	LVDS DDR input for data bus A,B,C,D (15:0)	I
DCLKIN[A,B,C,D]	LVDS inputs for data clock (200 - 400 MHz) on bus A, B, C, and D	I
DVALID[A,B,C,D]	LVDS input used to start write sequence for bus A, B, C, and D	I
ROWMD(1:0)	DMD row address and row counter control	I
ROWAD(10:0)	DMD row address pointer	I
BLK_AD(3:0)	DMD mirror block address pointer	I
BLK_MD(1:0)	DMD mirror block reset and clear command modes	I
PWR_FLOAT	Used to float DMD mirrors before complete loss of power	I
DMD_TYPE(3:0)	DMD type in use	O
RST_ACTIVE	Indicates DMD mirror reset in progress	O
INIT_ACTIVE	Initialization in progress.	O
VLED0	System "heartbeat" signal	O
VLED1	Denotes initialization complete	O

#### 8.3.4.1.1.2 Initialization

The *INIT\_ACTIVE* (Table 2) signal indicates that the DLP9500, DLPA200s, and DLPC410 are in an initialization state after power is applied. During this initialization period, the DLPC410 is initializing the DLP9500 and DLPA200s by setting all internal registers to their correct states. When this signal goes low, the system has completed initialization. System initialization takes approximately 220 ms to complete. Data and command write cycles should not be asserted during the initialization.

During initialization the user must send a training pattern to the DLPC410 on all data and DVALID lines to correctly align the data inputs to the data clock. For more information, see the interface training pattern information in the DLPC410 data sheet.

#### 8.3.4.1.1.3 DMD Device Detection

The DLPC410 automatically detects the DMD type and device ID. *DMD\_TYPE* (Table 2) is an output from the DLPC410 that contains the DMD information.

#### 8.3.4.1.1.4 Power Down

To ensure long term reliability of the DLP9500, a shutdown procedure must be executed. Prior to power removal, assert the *PWR\_FLOAT* (Table 2) signal and allow approximately 300  $\mu$ s for the procedure to complete. This procedure assures the mirrors are in a flat state.

### 8.3.4.1.2 DLPC410 to DMD Interface

#### 8.3.4.1.2.1 DLPC410 to DMD IO Description

Table 3 lists the available controls and status pin names and their corresponding signal type, along with a brief functional description.

**Table 3. DLPC410 to DMD I/O Pin Descriptions**

PIN NAME	DESCRIPTION	I/O
DDC_DOUT_[A,B,C,D](15:0)	LVDS DDR output to DMD data bus A,B,C,D (15:0)	O
DDC_DCLKOUT_[A,B,C,D]	LVDS output to DMD data clock A,B,C,D	O
DDC_SCTRL_[A,B,C,D]	LVDS DDR output to DMD data control A,B,C,D	O

### 8.3.4.1.2.2 Data Flow

Figure 9 shows the data traffic through the DLPC410. Special considerations are necessary when laying out the DLPC410 to allow best signal flow.

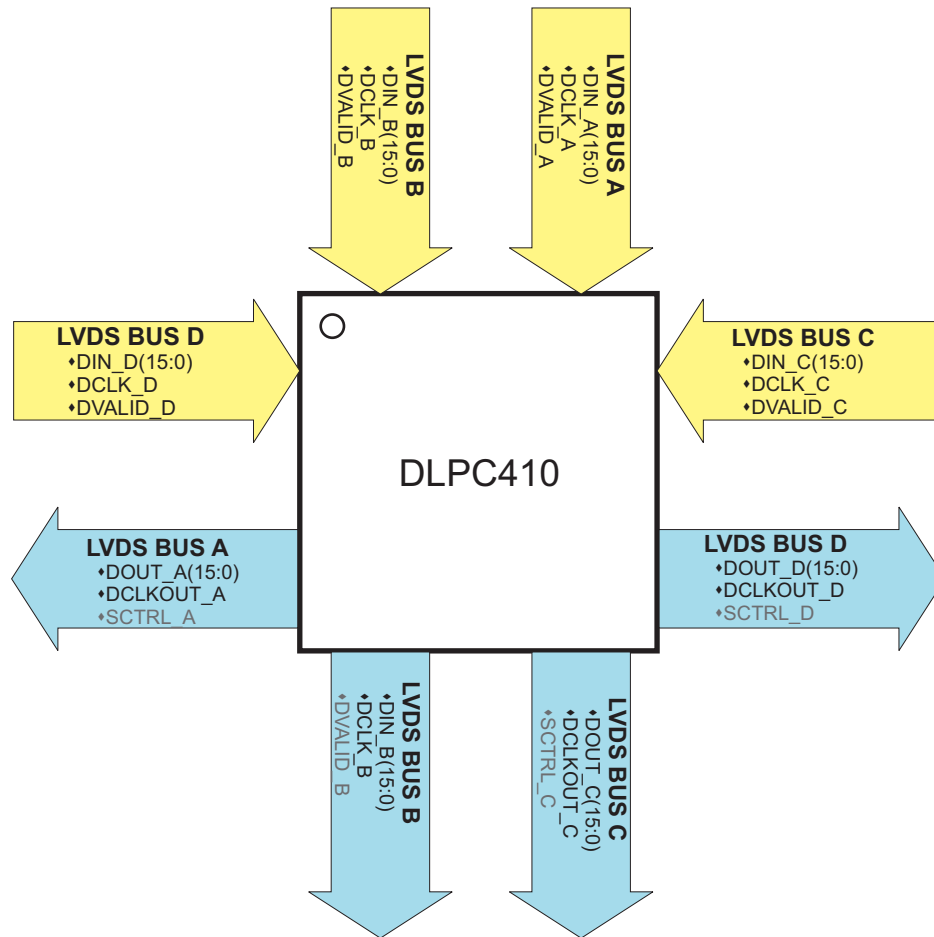

**Figure 9. DLPC410 Data Flow**

Four LVDS buses transfer the data from the user to the DLPC410. Each bus has its data clock that is input edge aligned with the data (DCLK). Each bus also has its own validation signal that qualifies the data input to the DLPC410 (DVALID).

Output LVDS buses transfer data from the DLPC410 to the DMD. Output buses LVDS C and LVDS D are used in addition to LVDS A and LVDS B with the DLP9500.

### 8.3.4.1.3 DLPC410 to DLPA200 Interface

#### 8.3.4.1.3.1 DLPA200 Operation

The DLPA200 DMD micromirror driver is a mixed-signal application-specific integrated circuit (ASIC) that combines the necessary high-voltage power supply generation and micromirror clocking pulse functions for a family of DMDs. The DLPA200 is programmable and controllable to meet all current and anticipated DMD requirements.

The DLPA200 operates from a 12-V power supply input. For more detailed information on the DLPA200, see the DLPA200 data sheet.

### 8.3.4.1.3.2 DLPC410 to DLPA200 IO Description

The serial communications port (SCP) is a full duplex, synchronous, character-oriented (byte) port that allows exchange of commands from the DLPC410 to the DLPA200s.

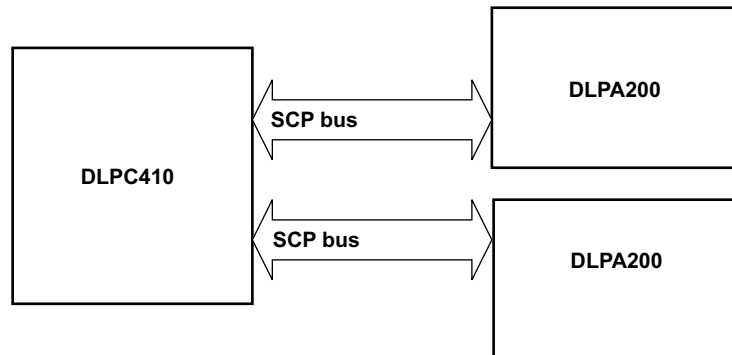

**Figure 10. Serial Port System Configuration**

Five signal lines are associated with the SCP bus:  $\overline{\text{SCPEN}}$ , SCPCCK, SCPDI, SCPDO, and  $\overline{\text{IRQ}}$ .

Table 4 lists the available controls and status pin names and their corresponding signal type, along with a brief functional description.

**Table 4. DLPC410 to DLPA200 I/O Pin Descriptions**

PIN NAME	DESCRIPTION	I/O
$\overline{\text{A\_SCPEN}}$	Active-low chip select for DLPA200 serial bus	O
A_STROBE	DLPA200 control signal strobe	O
A_MODE(1:0)	DLPA200 mode control	O
A_SEL(1:0)	DLPA200 select control	O
A_ADDR(3:0)	DLPA200 address control	O
$\overline{\text{B\_SCPEN}}$	Active-low chip select for DLPA200 serial bus (2)	O
B_STROBE	DLPA200 control signal strobe (2)	O
B_MODE(1:0)	DLPA200 mode control	O
B_SEL(1:0)	DLPA200 select control	O
B_ADDR(3:0)	DLPA200 address control	O

The DLPA200 provides a variety of output options to the DMD by selecting logic control inputs: MODE[1:0], SEL[1:0] and reset group address A[3:0] (Table 4). The MODE[1:0] input determines whether a single output, two outputs, four outputs, or all outputs, will be selected. Output levels (VBIAS, VOFFSET, or VRESET) are selected by SEL[1:0] pins. Selected outputs are tri-stated on the rising edge of the STROBE signal and latched to the selected voltage level after a break-before-make delay. Outputs will remain latched at the last micromirror clocking pulse waveform level until the next micromirror clocking pulse waveform cycle.

### 8.3.4.1.4 DLPA200 to DLP9500 Interface

#### 8.3.4.1.4.1 DLPA200 to DLP9500 Interface Overview

The DLPA200 generates three voltages: VBIAS, VRESET, and VOFFSET that are supplied to the DMD MBRST lines in various sequences through the micromirror clocking pulse driver function. VOFFSET is also supplied directly to the DMD as DMDVCC2. A fourth DMD power supply, DMDVCC, is supplied directly to the DMD by regulators.

The function of the micromirror clocking pulse driver is to switch selected outputs in patterns between the three voltage levels (VBIAS, VRESET and VOFFSET) to generate one of several micromirror clocking pulse waveforms. The order of these micromirror clocking pulse waveform events is controlled externally by the logic control inputs and timed by the STROBE signal. DLPC410 automatically detects the DMD type and then uses the DMD type to determine the appropriate micromirror clocking pulse waveform.

A direct micromirror clocking pulse operation causes a mirror to transition directly from one latched state to the next. The address must already be set up on the mirror electrodes when the micromirror clocking pulse is initiated. Where the desired mirror display period does not allow for time to set up the address, a micromirror clocking pulse with release can be performed. This operation allows the mirror to go to a relaxed state regardless of the address while a new address is set up, after which the mirror can be driven to a new latched state.

A mirror in the relaxed state typically reflects light into a system collection aperture and can be thought of as *off* although the light is likely to be more than a mirror latched in the *off* state. System designers should carefully evaluate the impact of relaxed mirror conditions on optical performance.

**8.3.5 Measurement Conditions**

The data sheet provides timing at the device pin. For output timing analysis, the tester pin electronics and its transmission line effects must be taken into account. [Figure 11](#) shows an equivalent test load circuit for the output under test. The load capacitance value stated is only for characterization and measurement of AC timing signals. This load capacitance value does not indicate the maximum load the device is capable of driving. All rise and fall transition timing parameters are referenced to  $V_{IL}$  MAX and  $V_{IH}$  MIN for input clocks,  $V_{OL}$  MAX and  $V_{OH}$  MIN for output clocks.

**LOAD CIRCUIT**

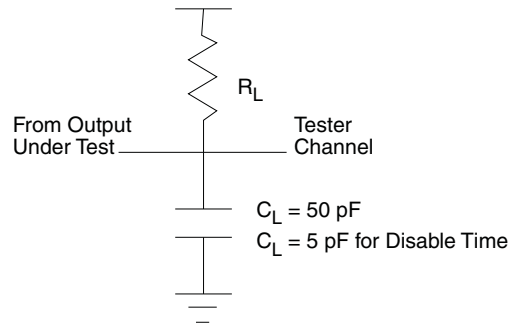

**Figure 11. Test Load Circuit for AC Timing Measurements**

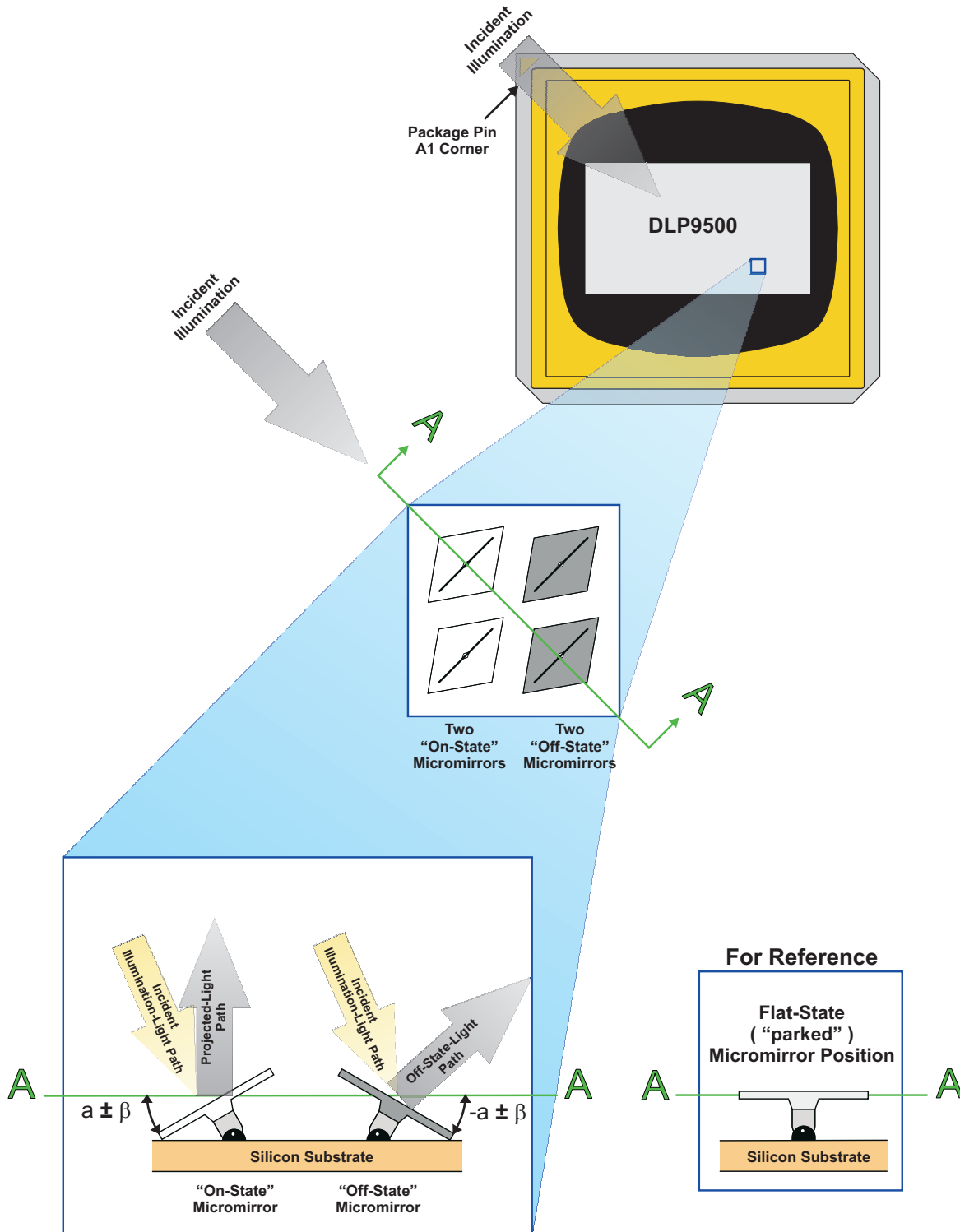

Figure 12. Micromirror Landed Positions and Light Paths

## 8.4 Device Functional Modes

The DLP9500 has only one functional mode; it is set to be highly optimized for low latency and high speed in generating mirror clocking pulses and timings.

When operated with the DLPC410 controller in conjunction with the DLPA200 drivers, the DLP9500 can be operated in several display modes. The DLP9500 is loaded as 15 blocks of 72 rows each. The first 64 bits of pixel data and last 64 bits of pixel data for all rows are not visible. Below is a representation of how the image is loaded by the different micromirror clocking pulse modes. Figure 13, Figure 14, Figure 15, and Figure 16 show how the image is loaded by the different micromirror clocking pulse modes.

There are four micromirror clocking pulse modes that determine which blocks are *reset* when a micromirror clocking pulse command is issued:

- Single block mode
- Dual block mode
- Quad block mode
- Global mode

### 8.4.1 Single Block Mode

In single block mode, a single block can be loaded and reset in any order. After a block is loaded, it can be reset to transfer the information to the mechanical state of the mirrors.

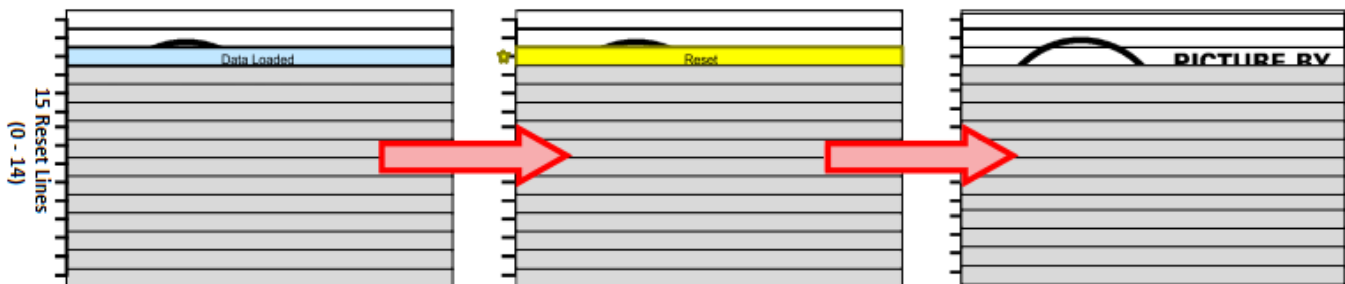

**Figure 13. Single Block Mode**

### 8.4.2 Dual Block Mode

In dual block mode, reset blocks are paired together as follows (0-1), (2-3), (4-5), (6-7), (8-9), (10-11), (12-13), and (14). These pairs can be reset in any order. After data is loaded a pair can be reset to transfer the information to the mechanical state of the mirrors.

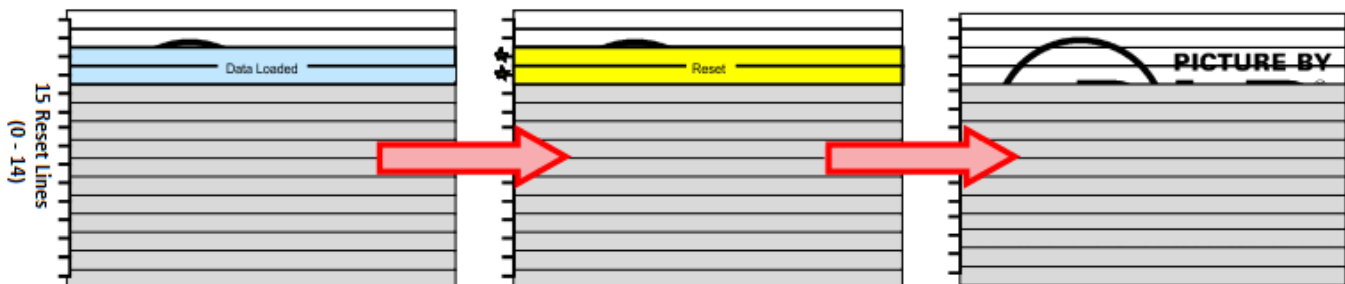

**Figure 14. Dual Block Mode**



**Device Functional Modes (continued)**

**8.4.3 Quad Block Mode**

In quad block mode, reset blocks are grouped together in fours as follows (0-3), (4-7), (8-11) and (12-14). Each quad group can be randomly addressed and reset. After a quad group is loaded, it can be reset to transfer the information to the mechanical state of the mirrors.

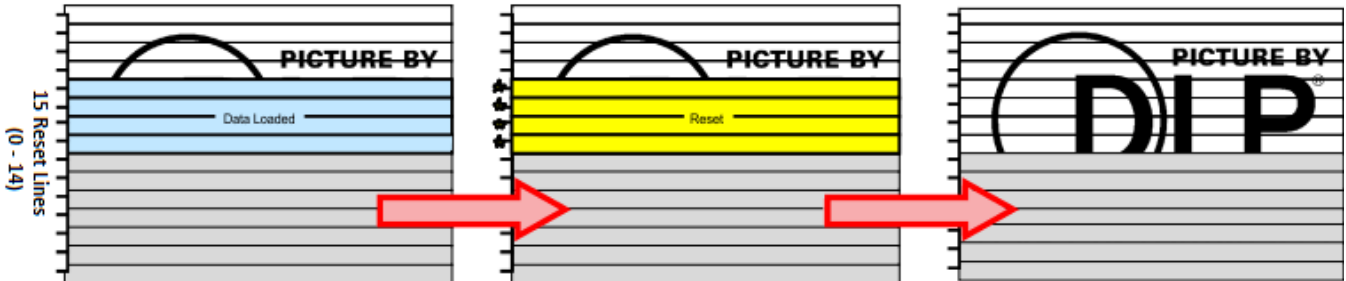

**Figure 15. Quad Block Mode**

**8.4.4 Global Block Mode**

In global mode, all reset blocks are grouped into a single group and reset together. The entire DMD must be loaded with the desired data before issuing a Global Reset to transfer the information to the mechanical state of the mirrors.

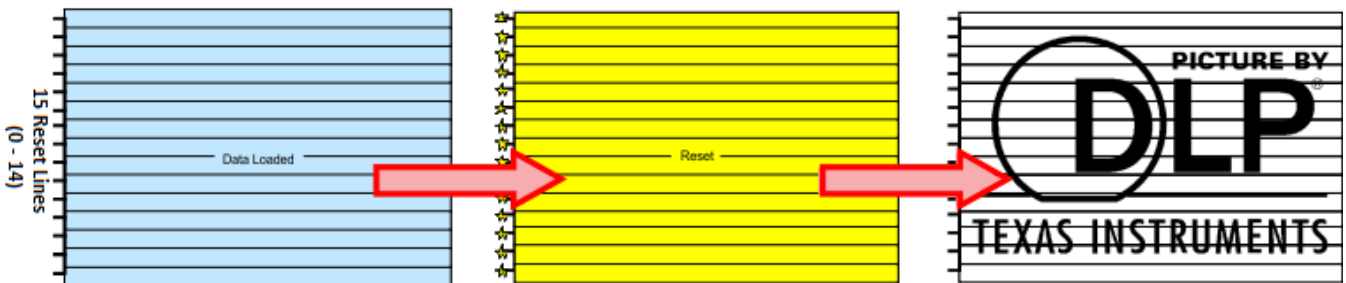

**Figure 16. Global Mode**

## 8.5 Window Characteristics and Optics

---

### NOTE

TI assumes no responsibility for image quality artifacts or DMD failures caused by optical system operating conditions exceeding limits described previously.

---

### 8.5.1 Optical Interface and System Image Quality

TI assumes no responsibility for end-equipment optical performance. Achieving the desired end-equipment optical performance involves making trade-offs between numerous component and system design parameters. Optimizing system optical performance and image quality strongly relate to optical system design parameter trades. Although it is not possible to anticipate every conceivable application, projector image quality and optical performance is contingent on compliance to the optical system operating conditions described in the following sections.

### 8.5.2 Numerical Aperture and Stray Light Control

The angle defined by the numerical aperture of the illumination and projection optics at the DMD optical area should be the same. This angle should not exceed the nominal device mirror tilt angle unless appropriate apertures are added in the illumination, projection pupils, or both to block out flat-state and stray light from the projection lens. The mirror tilt angle defines DMD capability to separate the *ON* optical path from any other light path, including undesirable flat-state specular reflections from the DMD window, DMD border structures, or other system surfaces near the DMD such as prism or lens surfaces. If the numerical aperture exceeds the mirror tilt angle, or if the projection numerical aperture angle is more than two degrees larger than the illumination numerical aperture angle, objectionable artifacts in the display's border and/or active area could occur.

### 8.5.3 Pupil Match

TI recommends the exit pupil of the illumination is nominally centered within 2° (two degrees) of the entrance pupil of the projection optics. Misalignment of pupils can create objectionable artifacts in the display's border and/or active area, which may require additional system apertures to control, especially if the numerical aperture of the system exceeds the pixel tilt angle.

### 8.5.4 Illumination Overfill

The active area of the device is surrounded by an aperture on the inside DMD window surface that masks structures of the DMD device assembly from normal view. The aperture is sized to anticipate several optical operating conditions. Overfill light illuminating the window aperture can create artifacts from the edge of the window aperture opening and other surface anomalies that may be visible on the screen. The illumination optical system should be designed to limit light flux incident anywhere on the window aperture from exceeding approximately 10% of the average flux level in the active area. Depending on the optical architecture of a particular system, overfill light may have to be further reduced below the suggested 10% level to be acceptable.

## 8.6 Micromirror Array Temperature Calculation

Achieving optimal DMD performance requires proper management of the maximum DMD case temperature, the maximum temperature of any individual micromirror in the active array, the maximum temperature of the window aperture, and the temperature gradient between case temperature and the predicted micromirror array temperature (see Figure 17).

See the *Recommended Operating Conditions* for applicable temperature limits.

### 8.6.1 Package Thermal Resistance

The DMD is designed to conduct absorbed and dissipated heat to the back of the type A package where it can be removed by an appropriate heat sink. The heat sink and cooling system must be capable of maintaining the package within the specified operational temperatures, refer to Figure 17. The total heat load on the DMD is typically driven by the incident light absorbed by the active area; although other contributions include light energy absorbed by the window aperture and electrical power dissipation of the array.

### 8.6.2 Case Temperature

The temperature of the DMD case can be measured directly. For consistency, thermal test point locations 1, 2, and 3 are defined, as shown in Figure 17.

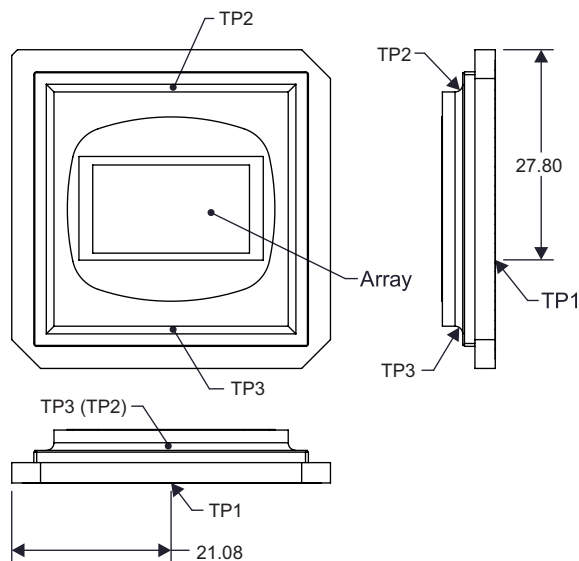

Figure 17. Thermal Test Point Location

## Micromirror Array Temperature Calculation (continued)

### 8.6.3 Micromirror Array Temperature Calculation

Micromirror array temperature cannot be measured directly; therefore, it must be computed analytically from measurement points (Figure 17), the package thermal resistance, the electrical power, and the illumination heat load. The relationship between micromirror array temperature and the case temperature are provided by Equation 1 and Equation 2:

$$T_{\text{Array}} = T_{\text{Ceramic}} + (Q_{\text{Array}} \times R_{\text{Array-To-Ceramic}}) \quad (1)$$

$$Q_{\text{Array}} = Q_{\text{ELE}} + Q_{\text{ILL}}$$

where

- $T_{\text{Array}}$  = Computed micromirror array temperature (°C)
- $T_{\text{Ceramic}}$  = Ceramic temperature (°C) (TP1 location Figure 17)
- $Q_{\text{Array}}$  = Total DMD array power (electrical + absorbed) (measured in Watts)
- $R_{\text{Array-To-Ceramic}}$  = Thermal resistance of DMD package from array to TP1 (°C/W) (see [Package Thermal Resistance](#))
- $Q_{\text{ELE}}$  = Nominal electrical power (W)
- $Q_{\text{ILL}}$  = Absorbed illumination energy (W) (2)

An example calculation is provided based on a traditional DLP video projection system. The electrical power dissipation of the DMD is variable and depends on the voltages, data rates, and operating frequencies. The nominal electrical power dissipation used in the calculation is 4.4 W. Thus,  $Q_{\text{ELE}} = 4.4$  W. The absorbed power from the illumination source is variable and depends on the operating state of the mirrors and the intensity of the light source. Based on modeling and measured data from DLP projection system:

$$Q_{\text{ILL}} = C_{\text{L2W}} \times \text{SL}$$

where

- $C_{\text{L2W}}$  is a lumens to watts constant and can be estimated at 0.00274 W/lm
- $\text{SL}$  = Screen lumens nominally measured to be 2000 lm
- $Q_{\text{Array}} = 4.4 + (0.00274 \times 2000) = 9.88$  W, estimated total power on micromirror array
- $T_{\text{Ceramic}} = 55^\circ\text{C}$ , assumed system measurement (3)

Finally,  $T_{\text{Array}}$  (micromirror active array temperature) is:

$$T_{\text{Array}} = 55^\circ\text{C} + (9.88 \text{ W} \times 0.5^\circ\text{C/W}) = 59.9^\circ\text{C} \quad (4)$$

## 8.7 Micromirror Landed-On and Landed-Off Duty Cycle

### 8.7.1 Definition of Micromirror Landed-On/Landed-Off Duty Cycle

The micromirror landed-on/landed-off duty cycle (landed duty cycle) denotes the amount of time (as a percentage) that an individual micromirror is landed in the On-state versus the amount of time the same micromirror is landed in the Off-state.

As an example, a landed duty cycle of 100/0 indicates that the referenced pixel is in the On-state 100% of the time (and in the Off-state 0% of the time); whereas 0/100 would indicate that the pixel is in the Off-state 100% of the time. Likewise, 50/50 indicates that the pixel is On 50% of the time and Off 50% of the time.

Note that when assessing landed duty cycle, the time spent switching from one state (ON or OFF) to the other state (OFF or ON) is considered negligible and is thus ignored.

Because a micromirror can only be landed in one state or the other (on or off), the two numbers (percentages) always add to 100.

### 8.7.2 Landed Duty Cycle and Useful Life of the DMD

Knowing the long-term average landed duty cycle (of the end product or application) is important because subjecting all (or a portion) of the DMD's micromirror array (also called the active array) to an asymmetric landed duty cycle for a prolonged period of time can reduce the usable life of the DMD.

Note that it is the symmetry/asymmetry of the landed duty cycle that is of relevance. The symmetry of the landed duty cycle is determined by how close the two numbers (percentages) are to being equal. For example, a landed duty cycle of 50/50 is perfectly symmetrical whereas a landed duty cycle of 100/0 or 0/100 is perfectly asymmetrical.

### 8.7.3 Landed Duty Cycle and Operational DMD Temperature

Operational DMD temperature and landed duty cycle interact to affect the usable life of the DMD, and this interaction can be exploited to reduce the impact that an asymmetrical landed duty cycle has on the DMD's usable life. This is quantified in the derating curve shown in [Figure 1](#). The importance of this curve is that:

- All points along this curve represent the same usable life.
- All points above this curve represent lower usable life (and the further away from the curve, the lower the usable life).
- All points below this curve represent higher usable life (and the further away from the curve, the higher the usable life).

In practice, this curve specifies the maximum operating DMD temperature that the DMD should be operated at for a given long-term average landed duty.

### 8.7.4 Estimating the Long-Term Average Landed Duty Cycle of a Product or Application

During a given period of time, the landed duty cycle of a given pixel follows from the image content being displayed by that pixel.

For example, in the simplest case, when displaying pure-white on a given pixel for a given time period, that pixel will experience a 100/0 landed duty cycle during that time period. Likewise, when displaying pure-black, the pixel will experience a 0/100 landed duty cycle.

Between the two extremes (ignoring for the moment color and any image processing that may be applied to an incoming image), the landed duty cycle tracks one-to-one with the gray scale value, as shown in [Table 5](#).

**Table 5. Grayscale Value and Landed Duty Cycle**

GRAYSCALE VALUE	LANDED DUTY CYCLE
0%	0/100
10%	10/90
20%	20/80
30%	30/70
40%	40/60
50%	50/50
60%	60/40
70%	70/30
80%	80/20
90%	90/10
100%	100/0

Accounting for color rendition (but still ignoring image processing) requires knowing both the color intensity (from 0% to 100%) for each constituent primary color (red, green, and/or blue) for the given pixel as well as the color cycle time for each primary color, where “color cycle time” is the total percentage of the frame time that a given primary must be displayed to achieve the desired white point.

During a given period of time, the landed duty cycle of a given pixel can be calculated as follows:

$$\text{Landed Duty Cycle} = (\text{Red\_Cycle\_}\% \times \text{Red\_Scale\_Value}) + (\text{Green\_Cycle\_}\% \times \text{Green\_Scale\_Value}) + (\text{Blue\_Cycle\_}\% \times \text{Blue\_Scale\_Value})$$

where:

Red\_Cycle\_%, Green\_Cycle\_%, and Blue\_Cycle\_%, represent the percentage of the frame time that Red, Green, and Blue are displayed (respectively) to achieve the desired white point.

For example, assume that the red, green and blue color cycle times are 50%, 20%, and 30% respectively (to achieve the desired white point), then the landed duty for various combinations of red, green, blue color intensities would be as shown in [Table 6](#).

**Table 6. Example Landed Duty Cycle for Full-Color**

RED CYCLE PERCENTAGE 50%	GREEN CYCLE PERCENTAGE 20%	BLUE CYCLE PERCENTAGE 30%	LANDED DUTY CYCLE
RED SCALE VALUE	GREEN SCALE VALUE	BLUE SCALE VALUE	
0%	0%	0%	0/100
100%	0%	0%	50/50
0%	100%	0%	20/80
0%	0%	100%	30/70
12%	0%	0%	6/94
0%	35%	0%	7/93
0%	0%	60%	18/82
100%	100%	0%	70/30
0%	100%	100%	50/50
100%	0%	100%	80/20
12%	35%	0%	13/87
0%	35%	60%	25/75
12%	0%	60%	24/76
100%	100%	100%	100/0

## 9 Application and Implementation

---

### NOTE

Information in the following applications sections is not part of the TI component specification, and TI does not warrant its accuracy or completeness. TI's customers are responsible for determining suitability of components for their purposes. Customers should validate and test their design implementation to confirm system functionality.

---

### 9.1 Application Information

The DLP9500 devices must be coupled with the DLPC410 controller to provide a reliable solution for many different applications. The DMDs are spatial light modulators which reflect incoming light from an illumination source to one of two directions, with the primary direction being into a projection collection optic. Each application is derived primarily from the optical architecture of the system and the format of the data coming into the DLPC410. Applications of interest include 3D printing, lithography, medical systems, and compressive sensing.

## 9.2 Typical Application

A typical embedded system application using the DLPC410 controller and DLP9500 is shown in Figure 18. In this configuration, the DLPC410 controller supports input from an FPGA. The FPGA sends low-level data to the controller, enabling the system to be highly optimized for low latency and high speed.

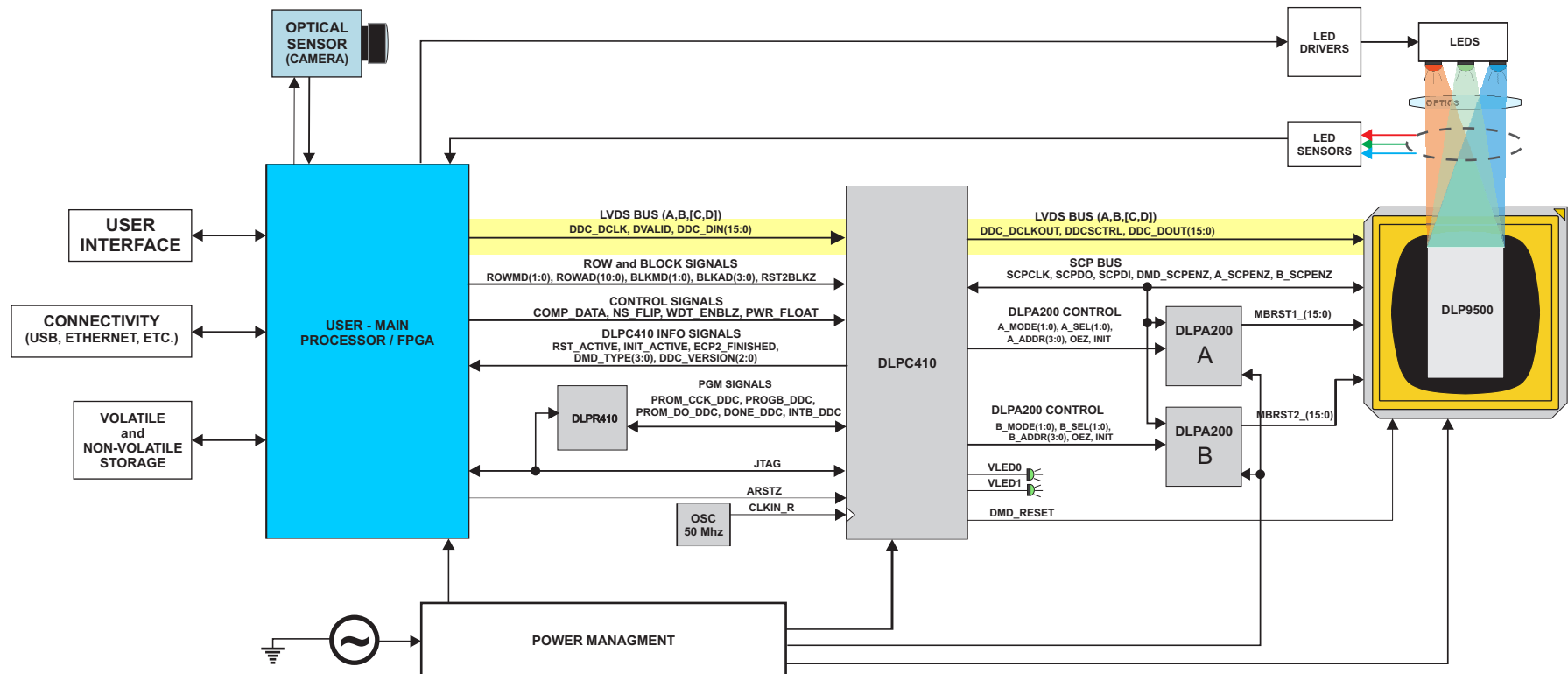

Figure 18. DLPC410 and DLP9500 Embedded Example Block Diagram



## 9.2.1 Design Requirements

All applications using the DLP9500 1080p chipset require both the controller and the DMD components for operation. The system also requires an external parallel flash memory device loaded with the DLPC410 configuration and support firmware. The chipset has several system interfaces and requires some support circuitry. The following interfaces and support circuitry are required:

- DLPC410 system interfaces:
  - Control interface
  - Trigger interface
  - Input data interface
  - Illumination interface
  - Reference clock
  - Program interface
- DLP9500 interfaces:
  - DLPC410 to DLP9500 digital data
  - DLPC410 to DLP9500 control interface
  - DLPC410 to DLP9500 micromirror reset control interface
  - DLPC410 to DLPA200 micromirror driver
  - DLPA200 to DLP9500 micromirror reset

### 9.2.1.1 Device Description

The DLP9500 1080p chipset offers developers a convenient way to design a wide variety of industrial, medical, telecom and advanced display applications by delivering maximum flexibility in formatting data, sequencing data, and light patterns.

The DLP9500 1080p chipset includes the following four components: DMD digital controller (DLPC410), EEPROM (DLPR410), DMD micromirror driver (DLPA200), and a DMD (DLP9500).

#### **DLPC410** Digital Controller for DLP Discovery 4100 chipset

- Provides high speed 2XLVDS data and control interface to the user.
- Drives mirror clocking pulse and timing information to the DLPA200.
- Supports random row addressing.
- Controls illumination

#### **DLPR410** PROM for DLP Discovery 4100 chipset

- Contains startup configuration information for the DLPC410

#### **DLPA200** DMD Micromirror Driver

- Generates micromirror clocking pulse control (sometimes referred to as a reset) of 15 banks of DMD mirrors. (Two are required for the DLP9500.)

#### **DLP9500** DLP 0.95 1080p 2xLVDS Type-A DMD

- Steers light in two digital positions (+12° and –12°) using 1920 x 1080 micromirror array of aluminum mirrors.

**Table 7. DLP DLP9500 Chipset Configurations**

QUANTITY	TI PART	DESCRIPTION
1	DLP9500	DLP 0.95 1080p 2xLVDS Type-A DMD
1	DLPC410	Digital Controller for DLP Discovery 4100 chipset
1	DLPR410	PROM for DLP Discovery 4100 chipset
2	DLPA200	DMD Micromirror Driver

Reliable function and operation of DLP9500 1080p chipsets require the components be used in conjunction with each other. This document describes the proper integration and use of the DLP9500 1080p chipset components.

The DLP9500 1080p chipset can be combined with a user programmable application FPGA (not included) to create high performance systems.

### 9.2.2 Detailed Design Procedure

The DLP9500 DMD is well suited for visible light applications requiring fast, spatially programmable light patterns using the micromirror array. See the block diagram in [Figure 8](#) to see the connections between the DLP9500 DMD, the DLPC410 digital controller, the DLPR410 EEPROM, and the DLPA200 DMD micromirror drivers. An example application block diagram can be found in [Figure 18](#). Layout guidelines should be followed for reliability.

## 10 Power Supply Recommendations

### 10.1 Power-Up Sequence (Handled by the DLPC410)

The sequence of events for DMD system power-up is:

1. Apply logic supply voltages to the DLPA200 and to the DMD according to DMD specifications.
2. Place DLPA200 drivers into high impedance states.
3. Turn on DLPA200 bias, offset, or reset supplies according to driver specifications.
4. After all supply voltages are assured to be within the limits specified and with all micromirror clocking pulse operations logically suspended, enable all drivers to either VOFFSET or VBIAS level.
5. Begin micromirror clocking pulse operations.

### 10.2 DMD Power-Up and Power-Down Procedures

Failure to adhere to the prescribed power-up and power-down procedures may affect device reliability. The DLP9500 power-up and power-down procedures are defined by the DLPC410 data sheet ([DLPS024](#)). These procedures must be followed to ensure reliable operation of the device.

## 11 Layout

### 11.1 Layout Guidelines

The DLP9500 is part of a chipset that is controlled by the DLPC410 in conjunction with the DLPA200. These guidelines are targeted at designing a PCB board with these components.

#### 11.1.1 Impedance Requirements

Signals should be routed to have a matched impedance of  $50\ \Omega \pm 10\%$  except for LVDS differential pairs (DMD\_DAT\_Xnn, DMD\_DCKL\_Xn, and DMD\_SCTRL\_Xn) which should be matched to  $100\ \Omega \pm 10\%$  across each pair.

#### 11.1.2 PCB Signal Routing

When designing a PCB board for the DLP9500 controlled by the DLPC410 in conjunction with the DLPA200s, the following are recommended:

Signal trace corners should be no sharper than  $45^\circ$ . Adjacent signal layers should have the predominate traces routed orthogonal to each other. TI recommends that critical signals be hand routed in the following order: DDR2 Memory, DMD (LVDS signals), then DLPA200 signals.

TI does not recommend signal routing on power or ground planes.

TI does not recommend ground plane slots.

High speed signal traces should not cross over slots in adjacent power and/or ground planes.

**Table 8. Important Signal Trace Constraints**

SIGNAL	CONSTRAINTS
LVDS (DMD_DAT_xnn, DMD_DCKL_xn, and DMD_SCTRL_xn)	P-to-N data, clock, and SCTRL: <10 mils (0.25 mm); Pair-to-pair <10 mils (0.25 mm); Bundle-to-bundle <2000 mils (50 mm, for example DMD_DAT_Ann to DMD_DAT_Bnn) Trace width: 4 mil (0.1 mm) Trace spacing: In ball field – 4 mil (0.11 mm); PCB etch – 14 mil (0.36 mm) Maximum recommended trace length <6 inches (150 mm)

**Table 9. Power Trace Widths and Spacing**

SIGNAL NAME	MINIMUM TRACE WIDTH	MINIMUM TRACE SPACING	LAYOUT REQUIREMENTS
GND	Maximize	5 mil (0.13 mm)	Maximize trace width to connecting pin as a minimum
VCC, VCC2	20 mil (0.51 mm)	10 mil (0.25 mm)	
MBRST[14:0]	11 mil (0.28 mm)	15 mil (0.38 mm)	

#### 11.1.3 Fiducials

Fiducials for automatic component insertion should be 0.05-inch copper with a 0.1-inch cutout (antipad). Fiducials for optical auto insertion are placed on three corners of both sides of the PCB.

#### 11.1.4 PCB Layout Guidelines

A target impedance of  $50\ \Omega$  for single ended signals and  $100\ \Omega$  between LVDS signals is specified for all signal layers.

##### 11.1.4.1 DMD Interface

The digital interface from the DLPC410 to the DMD are LVDS signals that run at clock rates up to 400 MHz. Data is clocked into the DMD on both the rising and falling edge of the clock, so the data rate is 800 MHz. The LVDS signals should have  $100\ \Omega$  differential impedance. The differential signals should be matched but kept as short as possible. Parallel termination at the LVDS receiver is in the DMD; therefore, on board termination is not necessary.

#### 11.1.4.1.1 Trace Length Matching

The DLPC410 DMD data signals require precise length matching. Differential signals should have impedance of 100  $\Omega$  (with 5% tolerance). It is important that the propagation delays are matched. The maximum differential pair uncoupled length is 100 mils with a relative propagation delay of  $\pm 25$  mil between the p and n. Matching all signals exactly will maximize the channel margin. The signal path through all boards, flex cables and internal DMD routing must be considered in this calculation.

#### 11.1.4.2 DLP9500 Decoupling

General decoupling capacitors for the DLP9500 should be distributed around the PCB and placed to minimize the distance from IC voltage and ground pads. Each decoupling capacitor (0.1  $\mu\text{F}$  recommended) should have vias directly to the ground and power planes. Via sharing between components (discrete or integrated) is discouraged. The power and ground pads of the DLP9500 should be tied to the voltage and ground planes with their own vias.

##### 11.1.4.2.1 Decoupling Capacitors

Decoupling capacitors should be placed to minimize the distance from the decoupling capacitor to the supply and ground pin of the component. TI recommends that the placement of and routing for the decoupling capacitors meet the following guidelines:

- The supply voltage pin of the capacitor should be located close to the device supply voltage pin or pins. The decoupling capacitor should have vias to ground and voltage planes. The device can be connected directly to the decoupling capacitor (no via) if the trace length is less than 0.1 inch. Otherwise, the component should be tied to the voltage or ground plane through separate vias.
- The trace lengths of the voltage and ground connections for decoupling capacitors and components should be less than 0.1 inch to minimize inductance.
- The trace width of the power and ground connection to decoupling capacitors and components should be as wide as possible to minimize inductance.
- Connecting decoupling capacitors to ground and power planes through multiple vias can reduce inductance and improve noise performance.
- Decoupling performance can be improved by using low ESR and low ESL capacitors.

##### 11.1.4.3 VCC and VCC2

The VCC pins of the DMD should be connected directly to the DMD VCC plane. Decoupling for the VCC should be distributed around the DMD and placed to minimize the distance from the voltage and ground pads. Each decoupling capacitor should have vias directly connected to the ground and power planes. The VCC and GND pads of the DMD should be tied to the VCC and ground planes with their own vias.

The VCC2 voltage can be routed to the DMD as a trace. Decoupling capacitors should be placed to minimize the distance from the DMD's VCC2 and ground pads. Using wide etch from the decoupling capacitors to the DMD connection will reduce inductance and improve decoupling performance.

##### 11.1.4.4 DMD Layout

See the respective sections in this data sheet for package dimensions, timing and pin out information.

##### 11.1.4.5 DLPA200

The DLPA200 generates the micromirror clocking pulses for the DMD. The DMD-drive outputs from the DLPA200 (MBRST[29:0]) should be routed with minimum trace width of 11 mil and a minimum spacing of 15 mil. The VCC and VCC2 traces from the output capacitors to the DLPA200 should also be routed with a minimum trace width and spacing of 11 mil and 15 mil, respectively. See the DLPA200 customer data sheet [DLPS015](#) for mechanical package and layout information.

## 11.2 Layout Example

For LVDS (and other differential signal) pairs and groups, it is important to match trace lengths. In the area of the dashed lines, [Figure 19](#) shows correct matching of signal pair lengths with serpentine sections to maintain the correct impedance.

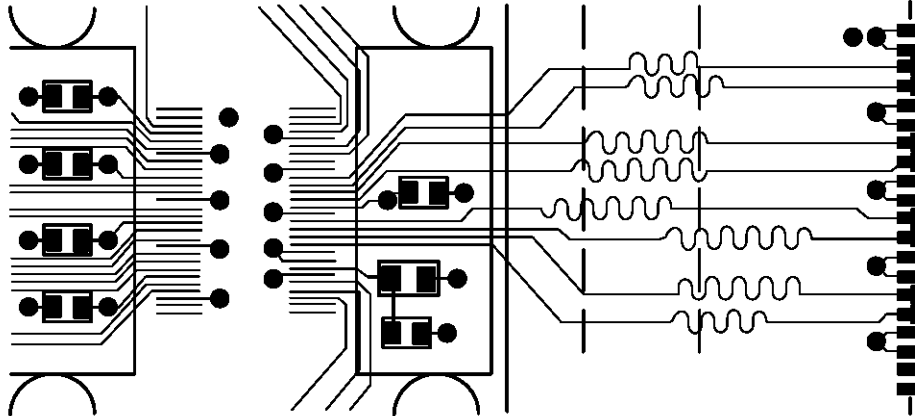

Figure 19. Mitering LVDS Traces to Match Lengths

## 12 Device and Documentation Support

### 12.1 Device Support

#### 12.1.1 Device Nomenclature

Figure 20 provides a legend of reading the complete device name for any DLP device.

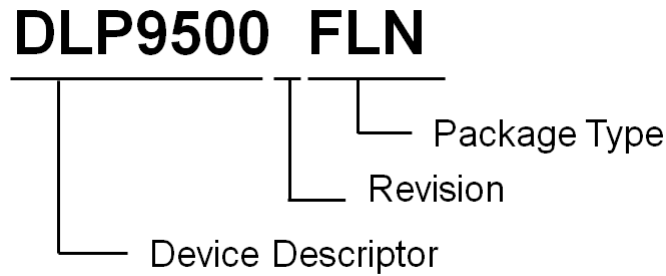

Figure 20. Device Nomenclature

#### 12.1.2 Device Marking

Figure 21 shows the device marking fields.

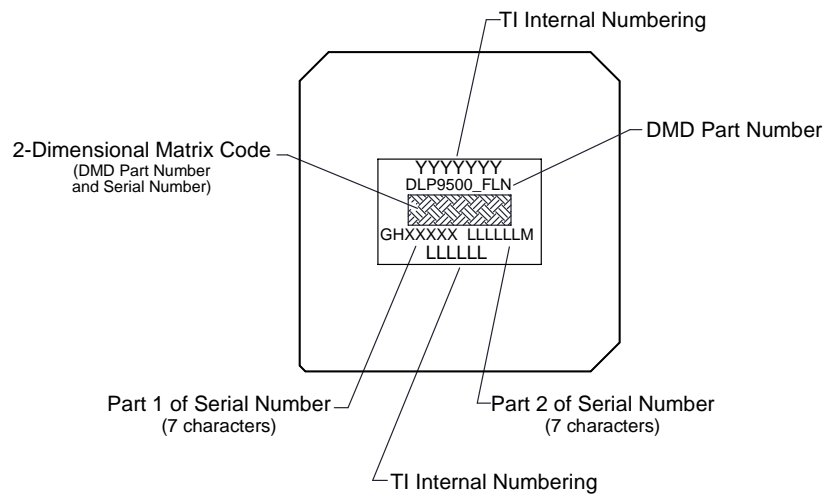

Figure 21. DLP9500 Device Marking

## 12.2 Documentation Support

### 12.2.1 Related Documentation

The following documents contain additional information related to the use of the DLP9500 device.

- [DLPC410](#) Digital Controller for DLP Discovery 4100 chipset data sheet
- [DLPA200](#) DMD Micromirror Driver data sheet
- [DLPR410](#) PROM for DLP Discovery 4100 chipset data sheet

### 12.3 Related Links

The table below lists quick access links. Categories include technical documents, support and community resources, tools and software, and quick access to sample or buy.

**Table 10. Related Links**

PARTS	PRODUCT FOLDER	SAMPLE & BUY	TECHNICAL DOCUMENTS	TOOLS & SOFTWARE	SUPPORT & COMMUNITY
DLP9500	<a href="#">Click here</a>	<a href="#">Click here</a>	<a href="#">Click here</a>	<a href="#">Click here</a>	<a href="#">Click here</a>
DLPA200	<a href="#">Click here</a>	<a href="#">Click here</a>	<a href="#">Click here</a>	<a href="#">Click here</a>	<a href="#">Click here</a>
DLPC410	<a href="#">Click here</a>	<a href="#">Click here</a>	<a href="#">Click here</a>	<a href="#">Click here</a>	<a href="#">Click here</a>
DLPR410	<a href="#">Click here</a>	<a href="#">Click here</a>	<a href="#">Click here</a>	<a href="#">Click here</a>	<a href="#">Click here</a>

### 12.4 Community Resources

The following links connect to TI community resources. Linked contents are provided "AS IS" by the respective contributors. They do not constitute TI specifications and do not necessarily reflect TI's views; see TI's [Terms of Use](#).

**TI E2E™ Online Community** *TI's Engineer-to-Engineer (E2E) Community*. Created to foster collaboration among engineers. At [e2e.ti.com](http://e2e.ti.com), you can ask questions, share knowledge, explore ideas and help solve problems with fellow engineers.

**Design Support** *TI's Design Support* Quickly find helpful E2E forums along with design support tools and contact information for technical support.

### 12.5 Trademarks

Discovery, E2E are trademarks of Texas Instruments.  
DLP is a registered trademark of Texas Instruments.  
All other trademarks are the property of their respective owners.

### 12.6 Electrostatic Discharge Caution



These devices have limited built-in ESD protection. The leads should be shorted together or the device placed in conductive foam during storage or handling to prevent electrostatic damage to the MOS gates.

### 12.7 Glossary

[SLYZ022](#) — *TI Glossary*.

This glossary lists and explains terms, acronyms, and definitions.

## 13 Mechanical, Packaging, and Orderable Information

The following pages include mechanical, packaging, and orderable information. This information is the most current data available for the designated devices. This data is subject to change without notice and revision of this document. For browser-based versions of this data sheet, refer to the left-hand navigation.

**PACKAGING INFORMATION**

Orderable Device	Status (1)	Package Type	Package Drawing	Pins	Package Qty	Eco Plan (2)	Lead/Ball Finish (6)	MSL Peak Temp (3)	Op Temp (°C)	Device Marking (4/5)	Samples
DLP9500BFLN	ACTIVE	LCCC	FLN	355	3	RoHS & Green	W NIPDAU	N / A for Pkg Type			Samples

(1) The marketing status values are defined as follows:

**ACTIVE:** Product device recommended for new designs.

**LIFEBUY:** TI has announced that the device will be discontinued, and a lifetime-buy period is in effect.

**NRND:** Not recommended for new designs. Device is in production to support existing customers, but TI does not recommend using this part in a new design.

**PREVIEW:** Device has been announced but is not in production. Samples may or may not be available.

**OBSOLETE:** TI has discontinued the production of the device.

(2) **RoHS:** TI defines "RoHS" to mean semiconductor products that are compliant with the current EU RoHS requirements for all 10 RoHS substances, including the requirement that RoHS substance do not exceed 0.1% by weight in homogeneous materials. Where designed to be soldered at high temperatures, "RoHS" products are suitable for use in specified lead-free processes. TI may reference these types of products as "Pb-Free".

**RoHS Exempt:** TI defines "RoHS Exempt" to mean products that contain lead but are compliant with EU RoHS pursuant to a specific EU RoHS exemption.

**Green:** TI defines "Green" to mean the content of Chlorine (Cl) and Bromine (Br) based flame retardants meet JS709B low halogen requirements of <=1000ppm threshold. Antimony trioxide based flame retardants must also meet the <=1000ppm threshold requirement.

(3) MSL, Peak Temp. - The Moisture Sensitivity Level rating according to the JEDEC industry standard classifications, and peak solder temperature.

(4) There may be additional marking, which relates to the logo, the lot trace code information, or the environmental category on the device.

(5) Multiple Device Markings will be inside parentheses. Only one Device Marking contained in parentheses and separated by a "~" will appear on a device. If a line is indented then it is a continuation of the previous line and the two combined represent the entire Device Marking for that device.

(6) Lead/Ball Finish - Orderable Devices may have multiple material finish options. Finish options are separated by a vertical ruled line. Lead/Ball Finish values may wrap to two lines if the finish value exceeds the maximum column width.

**Important Information and Disclaimer:** The information provided on this page represents TI's knowledge and belief as of the date that it is provided. TI bases its knowledge and belief on information provided by third parties, and makes no representation or warranty as to the accuracy of such information. Efforts are underway to better integrate information from third parties. TI has taken and continues to take reasonable steps to provide representative and accurate information but may not have conducted destructive testing or chemical analysis on incoming materials and chemicals. TI and TI suppliers consider certain information to be proprietary, and thus CAS numbers and other limited information may not be available for release.

In no event shall TI's liability arising out of such information exceed the total purchase price of the TI part(s) at issue in this document sold by TI to Customer on an annual basis.



NOTES: UNLESS OTHERWISE SPECIFIED:

- 1 INTERPRET DIMENSIONS IN ACCORDANCE WITH ASME Y14.5M-1994.
- 2 DATUM A (SYSTEM INTERFACE PLANE) ESTABLISHED BY THREE DATUM AREAS SHOWN IN VIEW A (SHEET 2).
- 3 DATUM B ESTABLISHED BY TWO DATUM AREAS SHOWN IN VIEW A (SHEET 2).
- 4 DATUM C ESTABLISHED BY DATUM AREA SHOWN IN VIEW A (SHEET 2).
- 5 LOCALIZED BACKSIDE SURFACE FLATNESS APPLIES TO ENTIRE SURFACE.
- 6 SUBSTRATE INDEX MARK, BACK INDEX PAD, SYMBOLIZATION PAD, SEAL RING, AND WINDOW FRAME TO BE ELECTRICALLY CONNECTED TO VSS PLANE IN SUBSTRATE.
- 7 THE DIMENSIONS OF THE SYMBOLIZATION PAD REPRESENT THE APPROXIMATE SIZE AND LOCATION OF THE RECOMMENDED THERMAL INTERFACE AREA.
- 8 ROTATION ANGLE OF DMD ACTIVE ARRAY IS A REFINEMENT OF THE LOCATION TOLERANCE AND IS THE MAXIMUM VALUE ALLOWED.
- 9 SUBSTRATE EDGE PERPENDICULARITY TOLERANCE APPLIES TO ENTIRE SURFACE.
- 10 DIE PARALLELISM TOLERANCE APPLIES TO DMD ACTIVE ARRAY ONLY.
- 11 DIE HEIGHT TOLERANCE APPLIES TO CENTER OF DMD ACTIVE ARRAY ONLY.
- 12 DMD ACTIVE ARRAY ROTATION AND LOCATION DIMENSIONS ARE RELATED TO DATUM A (PRIMARY), DATUM B (SECONDARY), AND DATUM C (TERTIARY).
- 13 WINDOW SHALL BE ORIENTED SUCH THAT I.D. MARK ALIGNS WITH SUBSTRATE INDEX MARK AS SHOWN.
- 14 ? IS A WILD CARD CHARACTER AND CAN BE ANY LETTER.

D  
C  
B  
A

D  
C  
B  
A

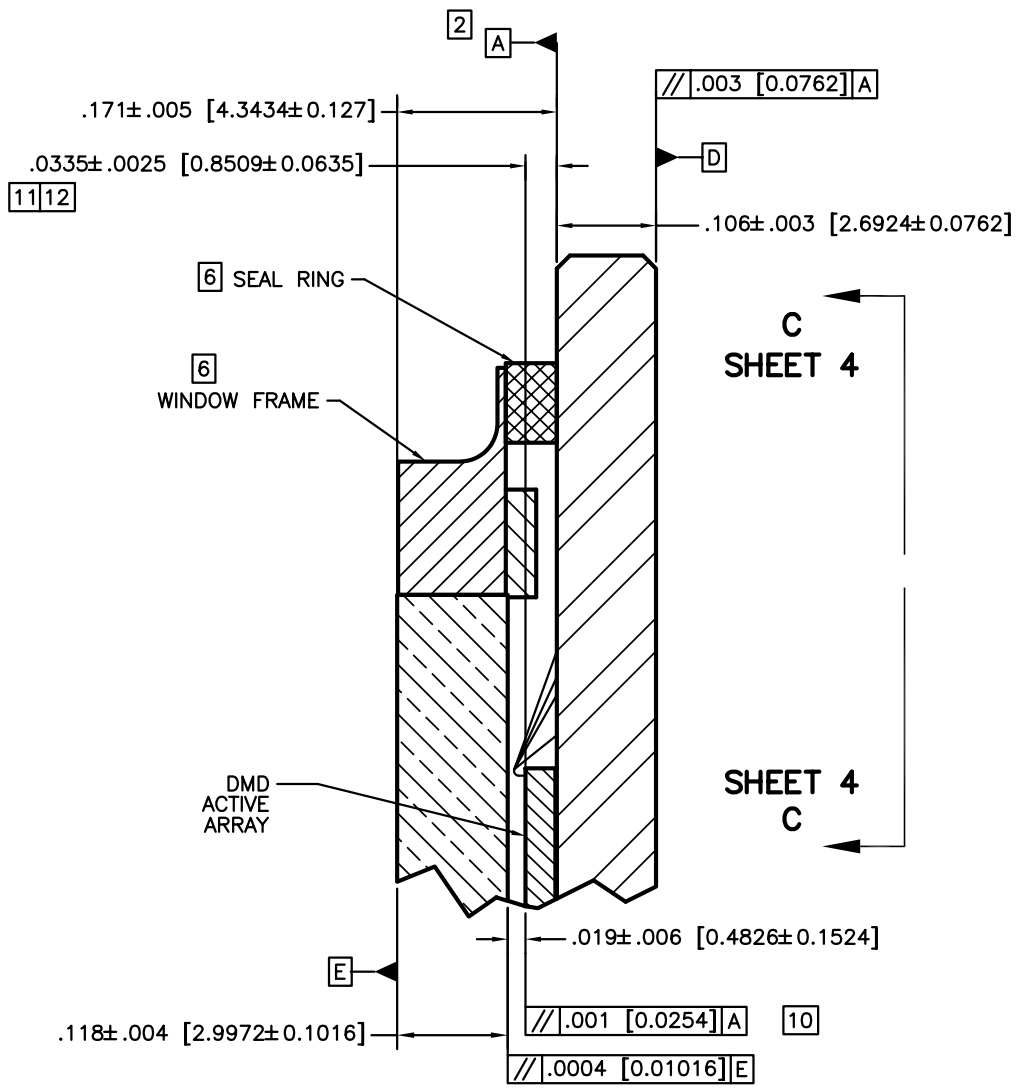
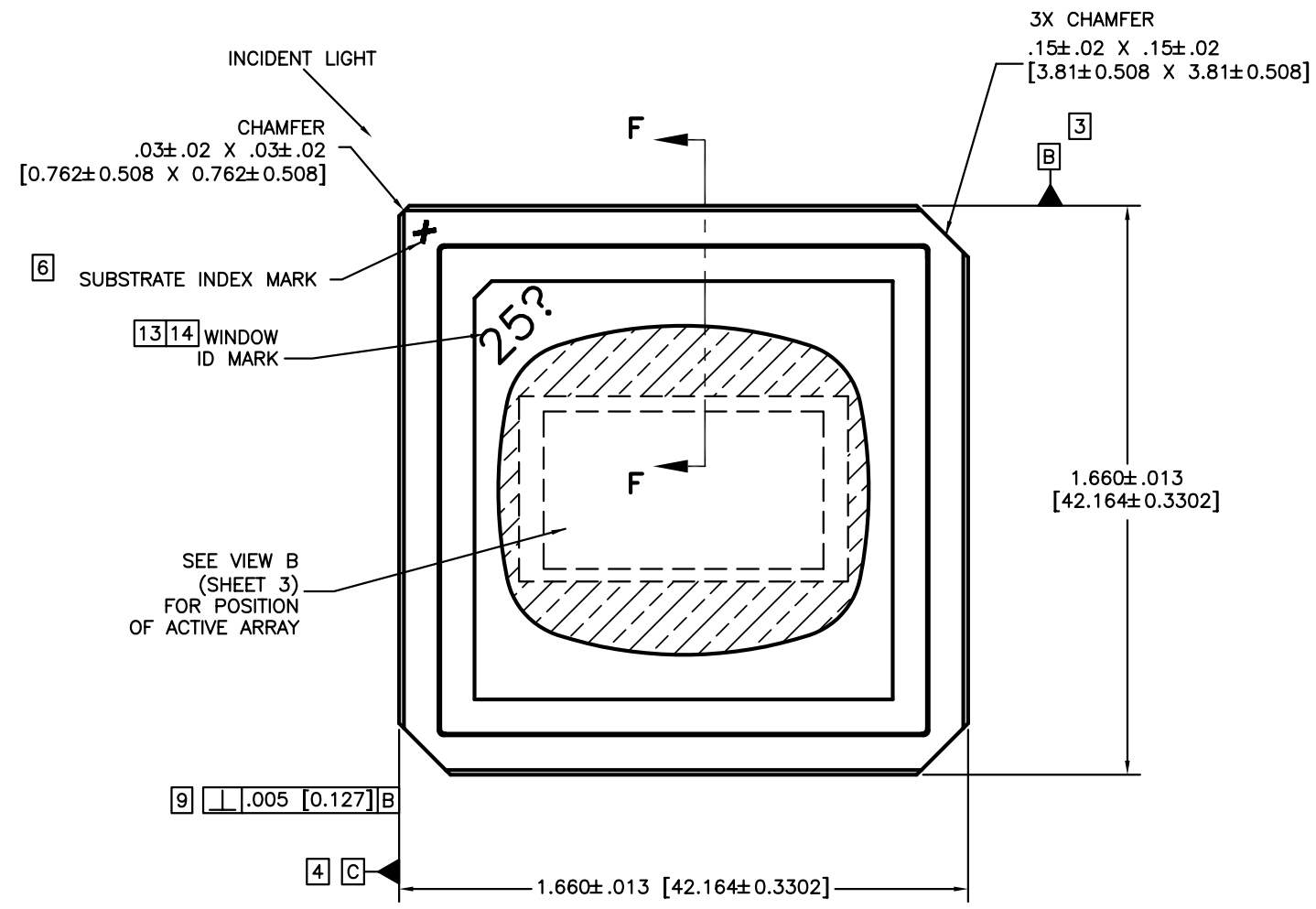

SECTION F-F  
SCALE 10/1

-1 QTY	ITEM NO	PART OR IDENTIFYING NUMBER	NOMENCLATURE OR DESCRIPTION	NOTES
			PARTS LIST	
			DWN M. AVERY DATE 2/28/05	 TEXAS INSTRUMENTS Dallas, Texas
			ENGR M. AVERY 2/28/05	
			QA	ICD, MECHANICAL, DMD .95" 1080p TYPE A
			APVD	
			SIZE D	DRAWING NO 2506491
			SCALE 4/1	REV A
				SHEET 1 OF 4

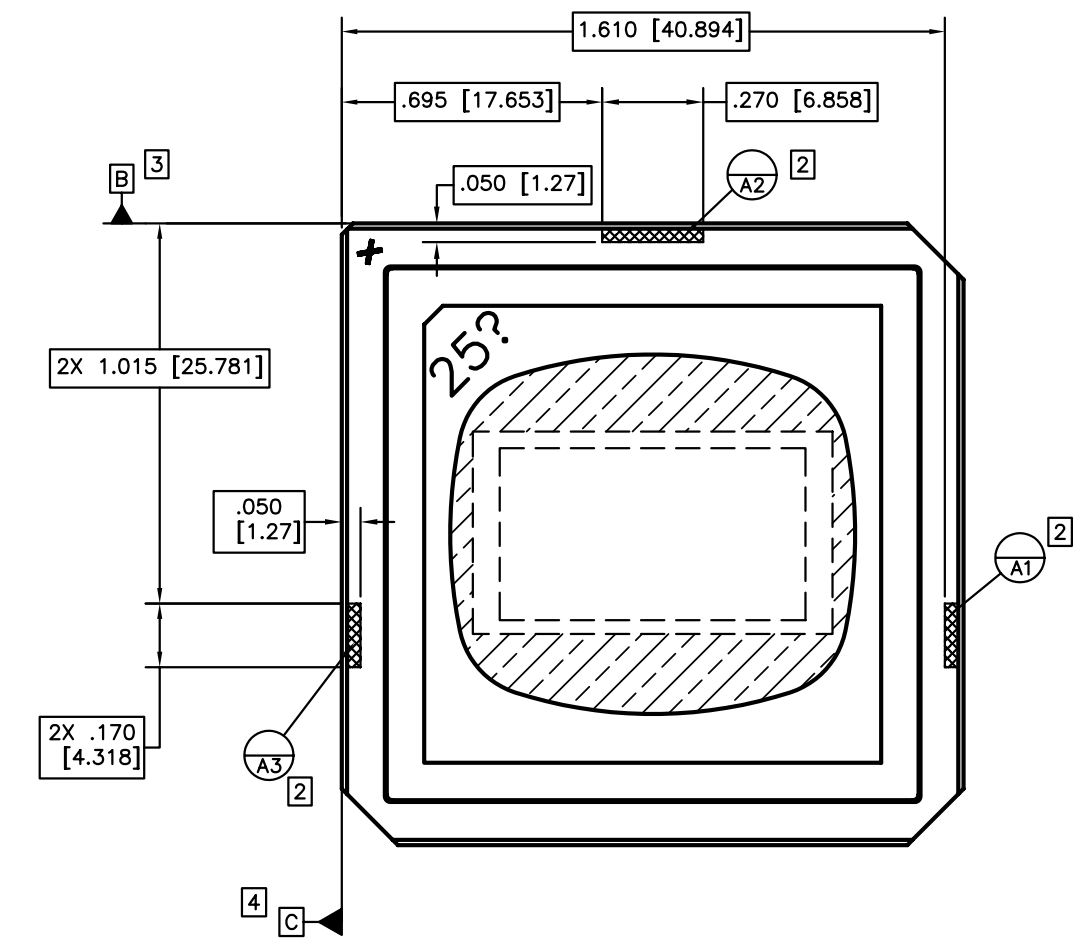
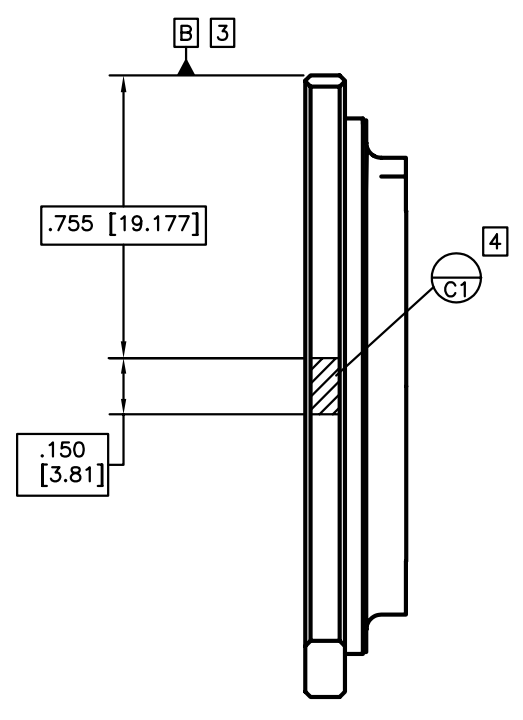
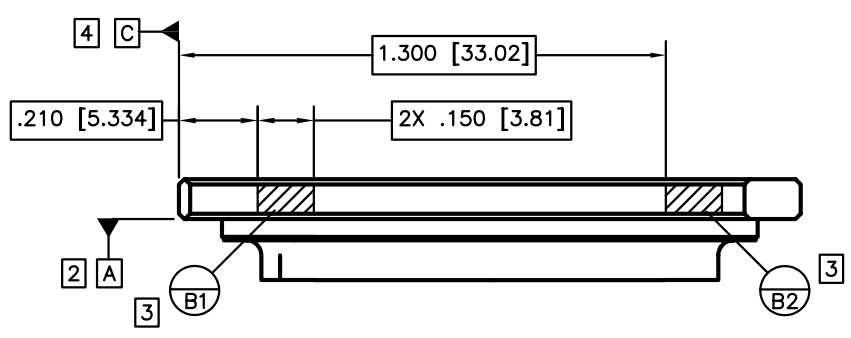

VIEW A (SHEET 1 NOTES)  
DATUM A, B AND C DETAILS

D D

C C

B B

A A

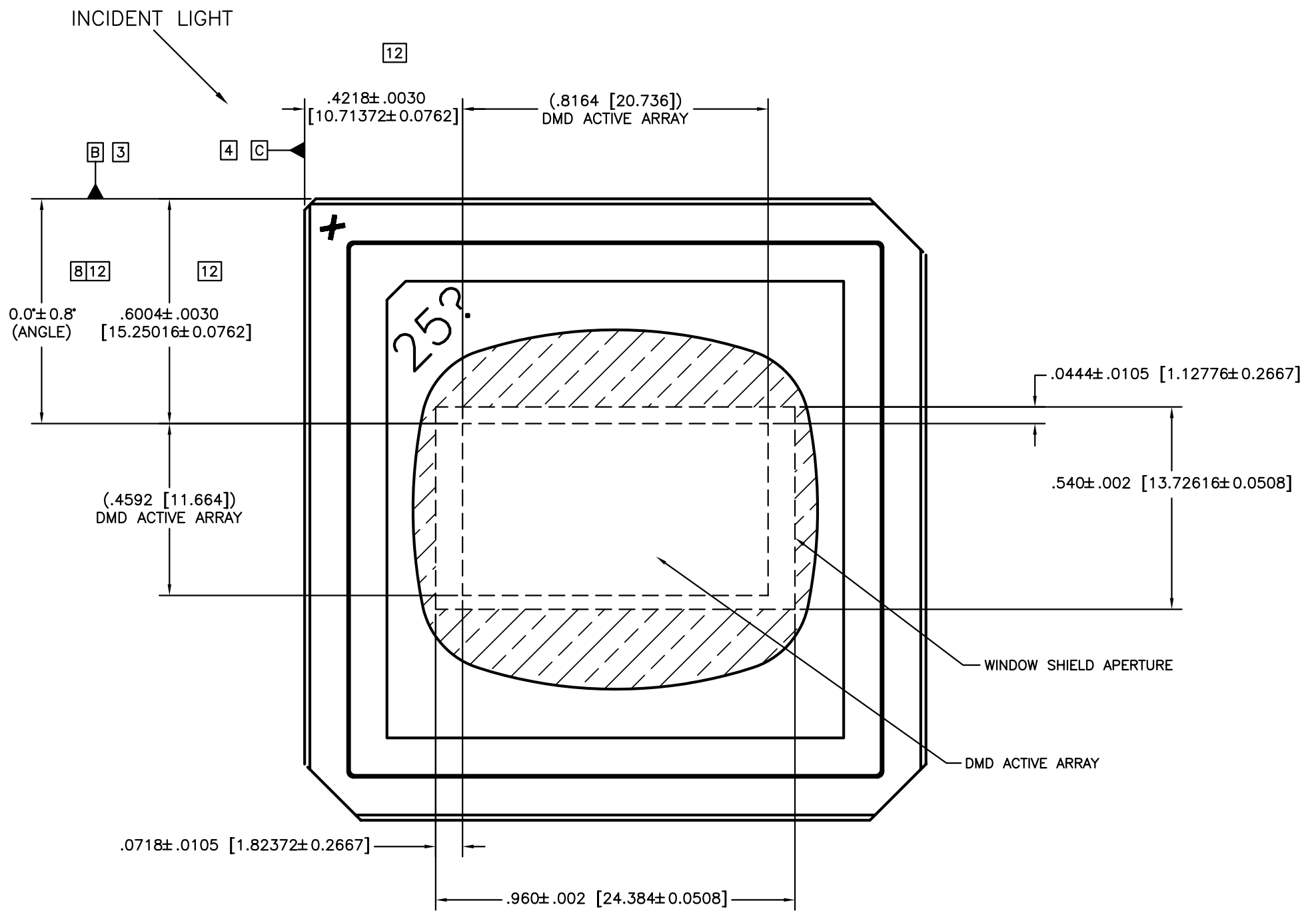

VIEW B (SHEET 1)  
POSITION OF ACTIVE ARRAY  
SCALE 6/1

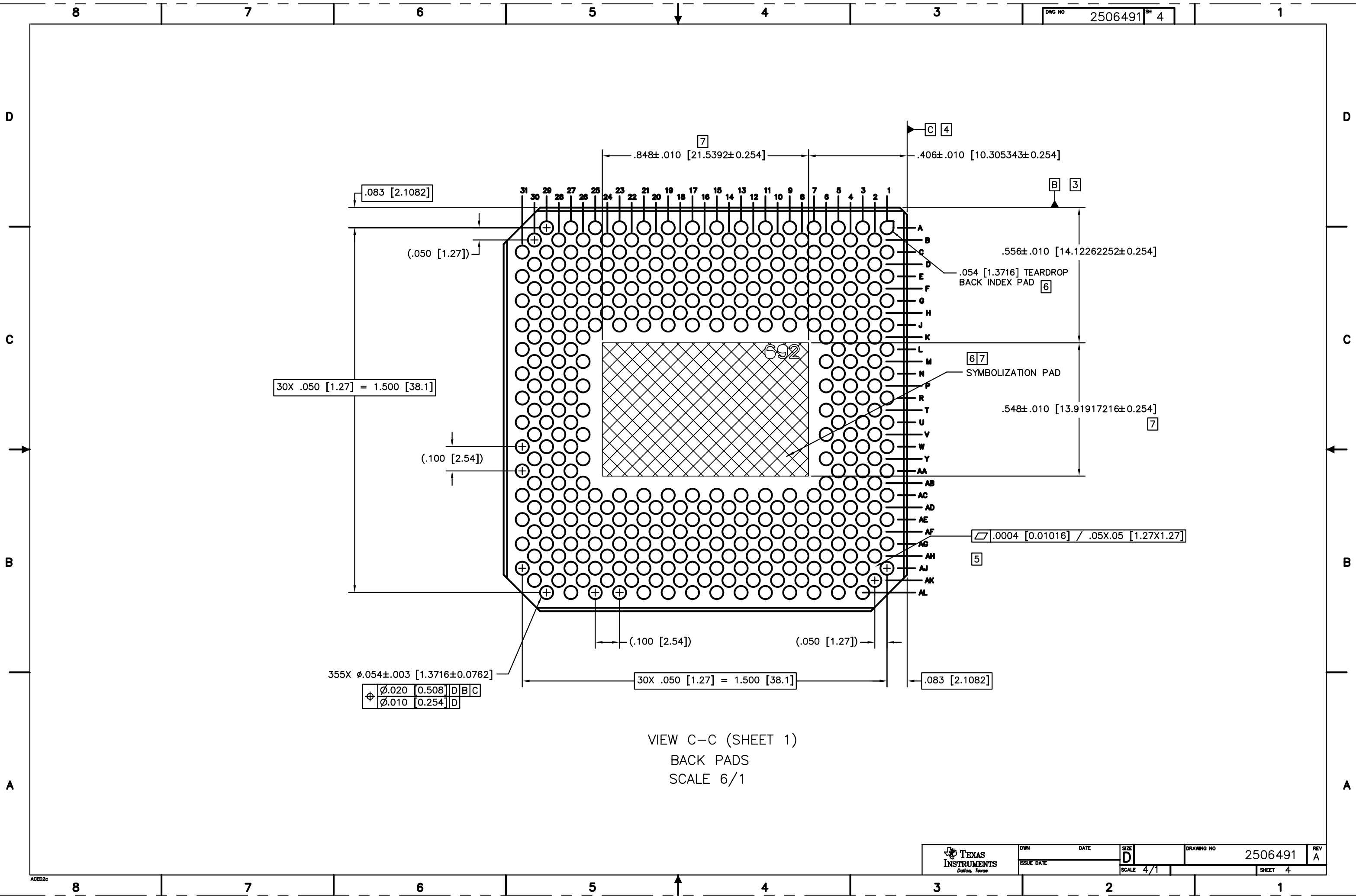

30X .050 [1.27] = 1.500 [38.1]

355X  $\phi$ .054 $\pm$ .003 [1.3716 $\pm$ 0.0762]

$\phi$	$\phi$ .020	[0.508]	D	B	C
	$\phi$ .010	[0.254]	D		

VIEW C-C (SHEET 1)  
BACK PADS  
SCALE 6/1

## IMPORTANT NOTICE

Texas Instruments Incorporated (TI) reserves the right to make corrections, enhancements, improvements and other changes to its semiconductor products and services per JESD46, latest issue, and to discontinue any product or service per JESD48, latest issue. Buyers should obtain the latest relevant information before placing orders and should verify that such information is current and complete.

TI's published terms of sale for semiconductor products (<http://www.ti.com/sc/docs/stdterms.htm>) apply to the sale of packaged integrated circuit products that TI has qualified and released to market. Additional terms may apply to the use or sale of other types of TI products and services.

Reproduction of significant portions of TI information in TI data sheets is permissible only if reproduction is without alteration and is accompanied by all associated warranties, conditions, limitations, and notices. TI is not responsible or liable for such reproduced documentation. Information of third parties may be subject to additional restrictions. Resale of TI products or services with statements different from or beyond the parameters stated by TI for that product or service voids all express and any implied warranties for the associated TI product or service and is an unfair and deceptive business practice. TI is not responsible or liable for any such statements.

Buyers and others who are developing systems that incorporate TI products (collectively, "Designers") understand and agree that Designers remain responsible for using their independent analysis, evaluation and judgment in designing their applications and that Designers have full and exclusive responsibility to assure the safety of Designers' applications and compliance of their applications (and of all TI products used in or for Designers' applications) with all applicable regulations, laws and other applicable requirements. Designer represents that, with respect to their applications, Designer has all the necessary expertise to create and implement safeguards that (1) anticipate dangerous consequences of failures, (2) monitor failures and their consequences, and (3) lessen the likelihood of failures that might cause harm and take appropriate actions. Designer agrees that prior to using or distributing any applications that include TI products, Designer will thoroughly test such applications and the functionality of such TI products as used in such applications.

TI's provision of technical, application or other design advice, quality characterization, reliability data or other services or information, including, but not limited to, reference designs and materials relating to evaluation modules, (collectively, "TI Resources") are intended to assist designers who are developing applications that incorporate TI products; by downloading, accessing or using TI Resources in any way, Designer (individually or, if Designer is acting on behalf of a company, Designer's company) agrees to use any particular TI Resource solely for this purpose and subject to the terms of this Notice.

TI's provision of TI Resources does not expand or otherwise alter TI's applicable published warranties or warranty disclaimers for TI products, and no additional obligations or liabilities arise from TI providing such TI Resources. TI reserves the right to make corrections, enhancements, improvements and other changes to its TI Resources. TI has not conducted any testing other than that specifically described in the published documentation for a particular TI Resource.

Designer is authorized to use, copy and modify any individual TI Resource only in connection with the development of applications that include the TI product(s) identified in such TI Resource. NO OTHER LICENSE, EXPRESS OR IMPLIED, BY ESTOPPEL OR OTHERWISE TO ANY OTHER TI INTELLECTUAL PROPERTY RIGHT, AND NO LICENSE TO ANY TECHNOLOGY OR INTELLECTUAL PROPERTY RIGHT OF TI OR ANY THIRD PARTY IS GRANTED HEREIN, including but not limited to any patent right, copyright, mask work right, or other intellectual property right relating to any combination, machine, or process in which TI products or services are used. Information regarding or referencing third-party products or services does not constitute a license to use such products or services, or a warranty or endorsement thereof. Use of TI Resources may require a license from a third party under the patents or other intellectual property of the third party, or a license from TI under the patents or other intellectual property of TI.

TI RESOURCES ARE PROVIDED "AS IS" AND WITH ALL FAULTS. TI DISCLAIMS ALL OTHER WARRANTIES OR REPRESENTATIONS, EXPRESS OR IMPLIED, REGARDING RESOURCES OR USE THEREOF, INCLUDING BUT NOT LIMITED TO ACCURACY OR COMPLETENESS, TITLE, ANY EPIDEMIC FAILURE WARRANTY AND ANY IMPLIED WARRANTIES OF MERCHANTABILITY, FITNESS FOR A PARTICULAR PURPOSE, AND NON-INFRINGEMENT OF ANY THIRD PARTY INTELLECTUAL PROPERTY RIGHTS. TI SHALL NOT BE LIABLE FOR AND SHALL NOT DEFEND OR INDEMNIFY DESIGNER AGAINST ANY CLAIM, INCLUDING BUT NOT LIMITED TO ANY INFRINGEMENT CLAIM THAT RELATES TO OR IS BASED ON ANY COMBINATION OF PRODUCTS EVEN IF DESCRIBED IN TI RESOURCES OR OTHERWISE. IN NO EVENT SHALL TI BE LIABLE FOR ANY ACTUAL, DIRECT, SPECIAL, COLLATERAL, INDIRECT, PUNITIVE, INCIDENTAL, CONSEQUENTIAL OR EXEMPLARY DAMAGES IN CONNECTION WITH OR ARISING OUT OF TI RESOURCES OR USE THEREOF, AND REGARDLESS OF WHETHER TI HAS BEEN ADVISED OF THE POSSIBILITY OF SUCH DAMAGES.

Unless TI has explicitly designated an individual product as meeting the requirements of a particular industry standard (e.g., ISO/TS 16949 and ISO 26262), TI is not responsible for any failure to meet such industry standard requirements.

Where TI specifically promotes products as facilitating functional safety or as compliant with industry functional safety standards, such products are intended to help enable customers to design and create their own applications that meet applicable functional safety standards and requirements. Using products in an application does not by itself establish any safety features in the application. Designers must ensure compliance with safety-related requirements and standards applicable to their applications. Designer may not use any TI products in life-critical medical equipment unless authorized officers of the parties have executed a special contract specifically governing such use. Life-critical medical equipment is medical equipment where failure of such equipment would cause serious bodily injury or death (e.g., life support, pacemakers, defibrillators, heart pumps, neurostimulators, and implantables). Such equipment includes, without limitation, all medical devices identified by the U.S. Food and Drug Administration as Class III devices and equivalent classifications outside the U.S.

TI may expressly designate certain products as completing a particular qualification (e.g., Q100, Military Grade, or Enhanced Product). Designers agree that it has the necessary expertise to select the product with the appropriate qualification designation for their applications and that proper product selection is at Designers' own risk. Designers are solely responsible for compliance with all legal and regulatory requirements in connection with such selection.

Designer will fully indemnify TI and its representatives against any damages, costs, losses, and/or liabilities arising out of Designer's non-compliance with the terms and provisions of this Notice.