

DESCRIPTION

The IF-E91A is a high-output medium-speed infrared LED in a “connector-less” style plastic fiber optic package. The output spectrum peaks at 950 nm for the IF-E91A. The device package features an internal micro-lens, and a precision-molded PBT housing ensures efficient optical coupling with standard 1000 μm plastic fiber cable.

APPLICATION HIGHLIGHTS

The high output and fast transition times of the IF-E91A are suitable for low-cost analog and digital data links. Used with an IF-D96 photologic detector, the IF-E91A can achieve data rates of 500 kbps at link distances up to 7 m. The drive circuit design is simpler than required for laser diodes, making the IF-E91A an excellent low-cost alternative in a variety of analog and digital applications.

APPLICATIONS

- Low Cost Analog and Digital Data Links
- Digitized Audio
- Optical Sensors
- Medical Instruments
- Robotics Communications
- Motor Controller Triggering
- EMC/EMI Signal Isolation
- Electronic Games
- Intra-System Links: Board-to-Board, Rack-to-Rack

FEATURES

- ◆ Excellent Linearity
- ◆ No Optical Design Required
- ◆ Mates with Standard 1000 μm Core Jacketed Plastic Fiber Cable
- ◆ Internal Micro-Lens for Efficient Coupling
- ◆ Inexpensive Plastic Connector Housing
- ◆ Connector-Less Fiber Termination and Connection
- ◆ Interference-Free Transmission from Light-Tight Housing
- ◆ RoHS Compliant

MAXIMUM RATINGS

(T_A = 25°C)

Operating and Storage Temperature Range (T _{OP} , T _{STG}).....	-40° to 85°C
Junction Temperature (T _J).....	85°C
Soldering Temperature (2 mm from case bottom) (T _S)t ≤ 5 s.....	240°C
Reverse Voltage (V _R).....	5 V
Power Dissipation (P _{TOT}) T _A = 25°C.....	80 mW
De-rate Above 25°C.....	1.33 mW/°C
Forward Current, DC (I _F) IF-E91A.....	50 mA
Surge Current (I _{FSM}) t ≤ 10 μsec IF-E91A.....	1.2 A

CHARACTERISTICS (T_A = 25°C)

Parameter	Symbol	Min.	Typ.	Max.	Unit
Peak Wavelength	λ _{PEAK}	–	940	–	nm
Spectral Bandwidth (50% of I _{MAX})	Δλ	–	±20	–	nm
Output Power Coupled into Plastic Fiber (1 mm core diameter). Distance Lens to Fiber ≤ 0.1 mm, 1 m SH4001 fiber, I _F =20 mA	Φ _{min}	50 -13	70 -11.6	95 -10.2	μW dBm
Switching Times (10% to 90% and 90% to 10%) (R _L =47Ω, I _F =10 mA)	t _r , t _f	–	1.0	–	μs
Capacitance (F=1 MHz)	C ₀	–	25	–	pF
Forward Voltage (I _F =20 mA) (I _F =50 mA)	V _f	–	1.2 1.27	1.6 1.6	V

CAUTION: The IF E91A is ESD sensitive. To minimize risk of damage observe appropriate precautions during handling and processing.

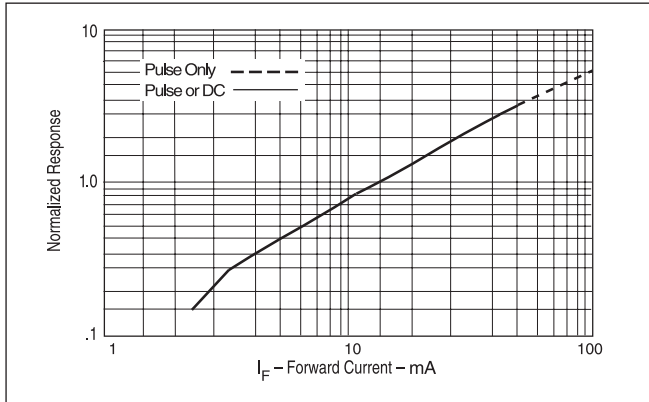

FIGURE 1. Normalized power launched versus forward current

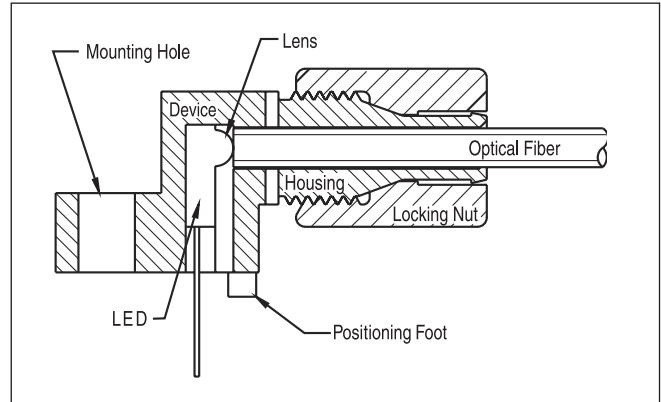

FIGURE 3. Cross-section of fiber optic device.

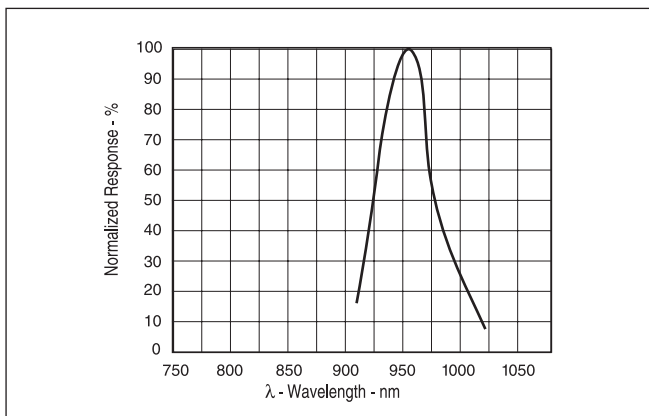

FIGURE 2. Typical spectral output versus wavelength.

FIBER TERMINATION INSTRUCTIONS

1. Cut off the ends of the optical fiber with a single-edge razor blade or sharp knife. Try to obtain a precise 90-degree angle (square).
2. Insert the fiber through the locking nut and into the connector until the core tip seats against the internal micro-lens.
3. Screw the connector locking nut down to a snug fit, locking the fiber in place.

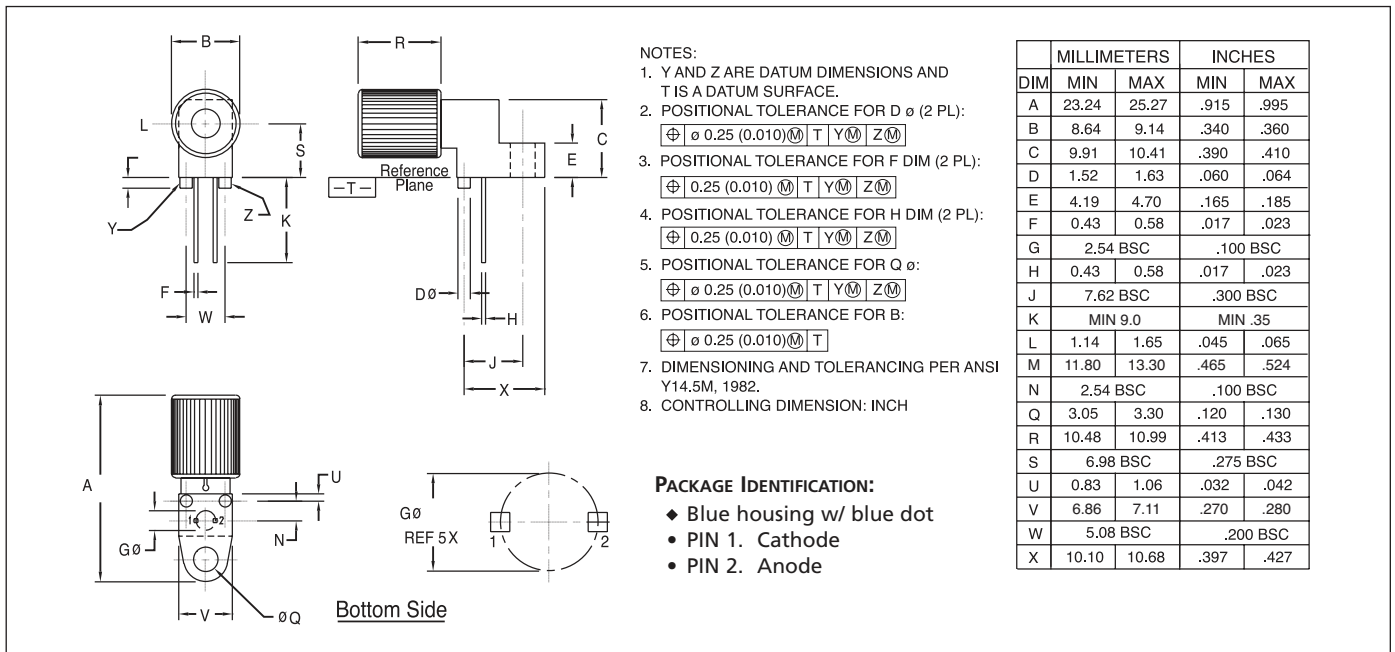

FIGURE 4. Case outline. Specifications are believed to be accurate but are subject to change. Industrial Fiber Optics assumes no responsibility for the consequences of using the information provided beyond replacement warranty for products not meeting stated specifications. Industrial Fiber Optics products are not authorized for use in life support applications without written approval from the President of Industrial Fiber Optics Corporation.

CAUTION:

- To avoid degraded device life due to package stress, do not bend or form leads outside the orientation shown on drawing.
- Ensure that solder flux does not migrate into the device and block the optical path, degrading the performance.
- If washing the device, liquid may become trapped in the part cavity. Ensure that all potentially corrosive materials are flushed out of the device.