

DESCRIPTION

The IF-E97 is a high-optical-output, visible red LED housed in a “connector-less” style plastic fiber optic package. The output spectrum is produced by a GaAlAs die which peaks at 660 nm, one of the optimal transmission windows of PMMA plastic optical fiber. The device package features an internal micro-lens and a precision-molded PBT housing to ensure efficient optical coupling with standard 1000 μm core plastic fiber cable.

APPLICATION HIGHLIGHTS

The high output and excellent linearity of the IF-E97 make it suitable for analog and digital data links. The IF-E97 can achieve data rates of 1 Mbps when used with an IF-D96 photologic detector. The visible red light has low attenuation in PMMA plastic fiber and aids in troubleshooting installations. The drive circuit design is simpler than required for laser diodes, making the IF-E97 the lowest cost selection for a variety of analog and digital applications requiring maximum operating distance.

APPLICATIONS

- Low Cost Analog and Digital Data Links
- Automotive Electronics
- Digitized Audio
- Medical Instruments
- PC-to-Peripheral Data Links
- Robotics Communications
- Motor Controller Triggering
- EMC/EMI Signal Isolation
- Local Area Networks
- Intra-System Links: Board-to-Board, Rack-to-Rack

FEATURES

- ◆ High Optical Power
- ◆ Visible Red Output Aids Troubleshooting
- ◆ Low Transmission Loss with PMMA Plastic Fiber
- ◆ No Optical Design required
- ◆ Mates with standard 1000 μm Core Jacketed Plastic Fiber Cable
- ◆ Internal Micro-Lens for Efficient Optical Coupling
- ◆ Inexpensive Plastic Connector Housing
- ◆ Connector-Less Fiber Termination
- ◆ Light-Tight Housing Provides Interference-Free Transmission
- ◆ RoHS compliant

MAXIMUM RATINGS

(T_A =25°C)
 Operating and Storage Temperature Range (T_{OP}, T_{STG}).....-40°to 85°C
 Junction Temperature (T_J).....85°C
 Soldering Temperature (2mm from case bottom) (T_S) t ≤ 5 s.....240°C
 Reverse Voltage (V_R).....5 V
 Power Dissipation (P_{TOT}) T_A =25°C.....100 mW
 De-rate Above 25°C.....1.33 mW/°C
 Forward Current, DC (I_F).....40 mA
 Surge Current (I_{FSM}) t ≤ 100 μs.....200 mA

CHARACTERISTICS (T_A =25°C)

Parameter	Symbol	Min.	Typ.	Max.	Unit
Peak Wavelength	λ _{PEAK}	650	660	670	nm
Full-Spectral Bandwidth (50% of I _{MAX})	Δλ	–	40	–	nm
Output Power Coupled into Plastic Fiber (1 mm core diameter). Distance Lens to Fiber ≤0.1 mm, 1m polished fiber, I _F =20 mA	Φ _{min}	250 -6.0	325 -4.9	425 -3.7	μW dBm
Switching Times (10% to 90% and 90% to 10%) (I _F =20 mA)	t _r , t _f	–	.5	–	μs
Capacitance (F=1 MHz)	C ₀	–	30	–	pF
Forward Voltage (I _F =20 mA)	V _f	1.7	1.9	2.1	V

CAUTION: The IF E97 is ESD sensitive. To minimize risk of damage observe appropriate precautions during handling and processing.

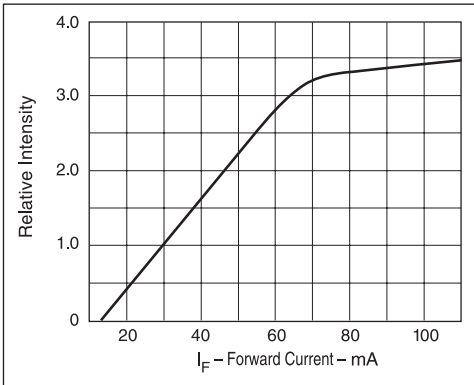

FIGURE 1. Normalized power launched versus forward current.

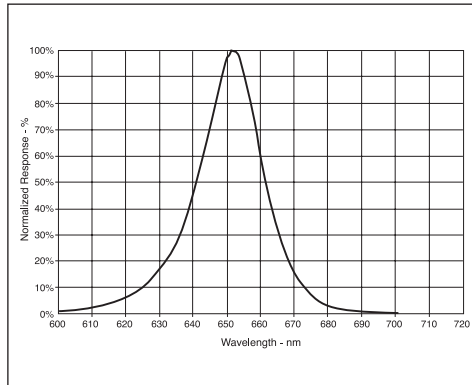

FIGURE 2. Typical spectral output versus wavelength.

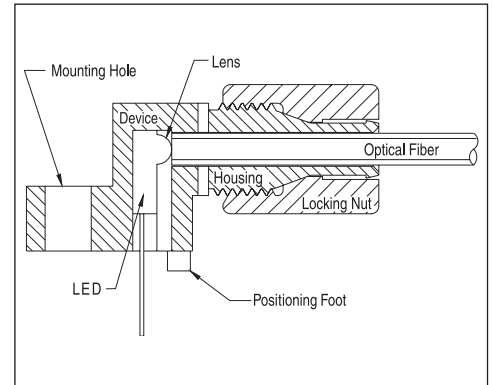

FIGURE 3. Cross-section of fiber optic device.

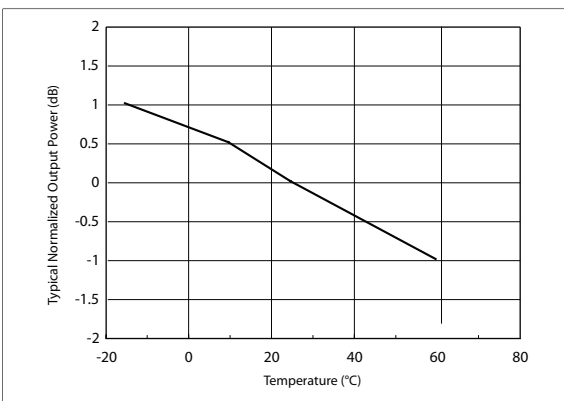
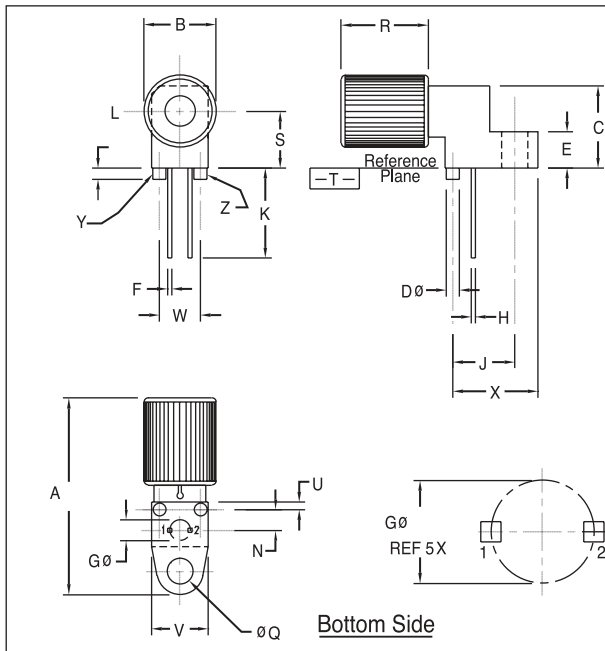

FIGURE 4. Output power versus temperature

FIBER TERMINATION INSTRUCTIONS

1. Cut off the ends of the optical fiber with a single-edge razor blade or sharp knife. Try to obtain a precise 90-degree angle (square).
2. Insert the fiber through the locking nut and into the connector until the core tip seats against the internal micro-lens.
3. Screw the connector locking nut down to a snug fit, locking the fiber in place.



NOTES:

1. Y AND Z ARE DATUM DIMENSIONS AND T IS A DATUM SURFACE.
2. POSITIONAL TOLERANCE FOR D ϕ (2 PL):
 $\phi 0.25 (0.010) \text{ (M) T } Y \text{ (M) Z (M)}$
3. POSITIONAL TOLERANCE FOR F DIM (2 PL):
 $\phi 0.25 (0.010) \text{ (M) T } Y \text{ (M) Z (M)}$
4. POSITIONAL TOLERANCE FOR H DIM (2 PL):
 $\phi 0.25 (0.010) \text{ (M) T } Y \text{ (M) Z (M)}$
5. POSITIONAL TOLERANCE FOR Q ϕ (2 PL):
 $\phi 0.25 (0.010) \text{ (M) T } Y \text{ (M) Z (M)}$
6. POSITIONAL TOLERANCE FOR B (2 PL):
 $\phi 0.25 (0.010) \text{ (M) T}$
7. DIMENSIONING AND TOLERANCING PER ANSI Y14.5M, 1982.
8. CONTROLLING DIMENSION: INCH

PACKAGE IDENTIFICATION:

- ◆ Blue housing w/ Red dot
- PIN 1. Cathode
- PIN 2. Anode

DIM	MILLIMETERS		INCHES	
	MIN	MAX	MIN	MAX
A	23.24	25.27	.915	.995
B	8.64	9.14	.340	.360
C	9.91	10.41	.390	.410
D	1.52	1.63	.060	.064
E	4.19	4.70	.165	.185
F	0.43	0.58	.017	.023
G	2.54 BSC		.100 BSC	
H	0.43	0.58	.017	.023
J	7.62 BSC		.300 BSC	
K	MIN 9.0		MIN .35	
L	1.14	1.65	.045	.065
N	2.54 BSC		.100 BSC	
Q	3.05	3.30	.120	.130
R	10.48	10.99	.413	.433
S	6.98 BSC		.275 BSC	
U	0.83	1.06	.032	.042
V	7.49	7.75	.295	.305
W	5.08 BSC		.200 BSC	
X	10.10	10.68	.397	.427

FIGURE 5. Case outline. Specifications are believed to be accurate but are subject to change. Industrial Fiber Optics assumes no responsibility for the consequences of using the information provided beyond replacement warranty for products not meeting stated specifications. Industrial Fiber Optics products are not authorized for use in life support applications without written approval from the President of Industrial Fiber Optics Corporation.

- CAUTION:**
- To avoid degraded device life due to package stress, do not bend or form leads outside the orientation shown on drawing.
 - Ensure that solder flux does not migrate into the device and block the optical path, degrading the performance.
 - If washing the device, liquid may become trapped in the part cavity. Ensure that all potentially corrosive materials are flushed out of the device.